

Distributors of Municipal, Industrial and Contractors' Equipment

Sask. (306) 569-9041
Man. (204) 253-2473

Fax: (306) 757-4254
Website: www.fer-marc.com

Etnyre Lubrication Chart

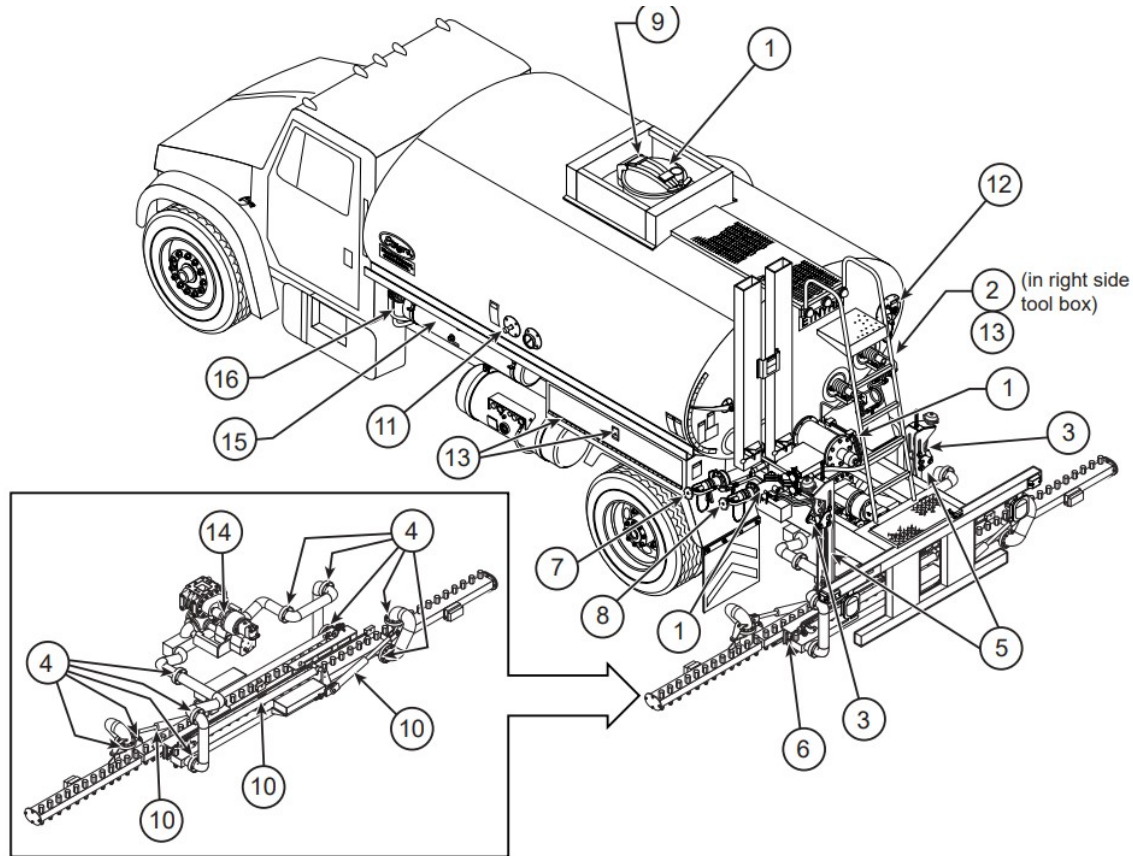

| INTERVAL | POINT | IDENTIFICATION | LUBRICANT | QUANTITY |
|----------------|-------|--|-----------|----------------------------|
| DAILY | 1 | Strainers (Fill Line, Manhole, Strainer Box) | Clean | - |
| | 17 | Spray Valves | HTG | Sparingly |
| WEEKLY | 2 | Air Oiler | EO | Fill |
| MONTHLY | 3 | Bar Latches | EO | Sparingly |
| | 4 | Swivels | MPG | Sparingly |
| | 5 | Bar Carry Mechanism | EO | Sparingly |
| | 6 | Bar Shoe Slide Plates | AS | Sparingly |
| | 7 | Transfer Side Cap | AS | Sparingly |
| | 8 | Load Line Cap | AS | Sparingly |
| | 9 | Manhole Lid | AS | Sparingly |
| | 10 | Exposed Hydraulic Air Cylinder Rods | EO | Sparingly |
| | 11 | Thermometer Cap | As | Sparingly |
| | 13 | Toolbox Hinge And Latch | EO | Sparingly |
| SERVICE | 14 | Pump Shaft Coupling | AS | Sparingly |
| | 15 | Hydraulic Reservoir | HTF | Fill To Top OF Sight Glass |
| | 16 | Hydraulic Oil Filter | - | Replace When Gauge Is Red |

MPG: Multi-Purpose Grease MIL-G-18458B-SH

EO: (Engine Oil) 10W MIL-L-2104-F

AS: Anti-Seize MIL-T-5544

HTF: Hydraulic Transmission Fluid - Type F

HTG: High Temperature Grease (450°F)

NOTE: Fill Line Oiler, Located On Outlet Side Of Air Reservoir, With Light Oil As Needed. Also Wipe Cylinder Rods Clean And Lightly Oil. Drain Water From Air Reservoir Daily.

NOTE: Fill Hydraulic Tank Completely For Winter Storage. This Will Prevent Condensation In The Reservoir. Drain Down To Thermometer Hole Prior To Use.

NOTE: Grease Spray Valves Until Grease Exits Opposite Side. Grease After Cleaning Spray Bar With Solvents Or High-Pressure Water And Before And After Spraying Hot (+400°F) Asphalt.

Etnyre Spray Bar Nozzles

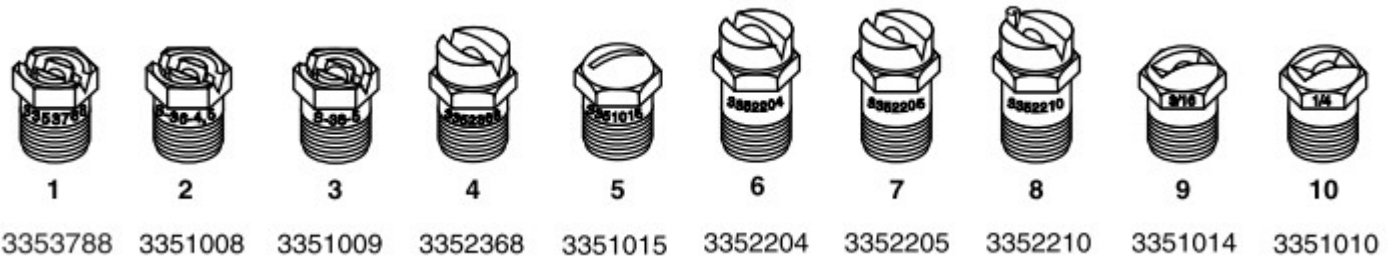

| Ref. | Part No. | Description | Application Gallons Per Square Yard | Application (Metric) Litres Per Square Meter | US Flow Gallons Per Minute Per Foot |
|------|----------|-----------------------|---|---|---|
| 1 | 3353788 | V Slot Tack Nozzle | .05 - .20 | .23 - .91 | 3.0 - 4.5 |
| 2 | 3351008 | S36-4 V Slot | .10 - .35 | .45 - 1.58 | 4.0 - 7.5 |
| 3 | 3351009 | S36-5 V Slot | .18 - .45 | .81 - 2.04 | 7.0 - 10.0 |
| 4 | 3352368 | Multi-Material V Slot | .15 - .40 | .68 - 1.81 | 6.0 - 9.0 |
| 5 | 3351015 | 38/32" Coin Slot | .15 - .40 | .68 - 1.81 | 6.0 - 9.0 |
| 6 | 3342204* | Multi Material V-Slot | .35 - .95 | 1.58 - 4.30 | 12.0 - 21.0 |
| 7 | 3352205* | Multi-Material V Slot | .20 - .55 | .91 - 2.49 | 7.5 - 12.0 |
| 8 | 3352210 | End Nozzle (3352205) | .20 - .55 | .91 - 2.49 | 7.5 - 12.0 |
| 9 | 3351014 | 3/16" Coin Slot | .35 - .95 | 1.58 - 4.30 | 12.0 - 21.0 |
| 10 | 3351010 | 1/4" Coin Slot | .40 - 1.10 | 1.81 - 4.98 | 15.0 - 24.0 |

*Recommended Nozzles For Seal And chip with Emulsified Asphalts.