

M-209-91

For Units with Serial Numbers
K-5126 and After

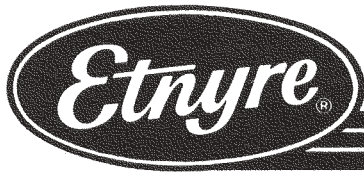

HYDROSTATIC DRIVE CHIPSPREADER

OPERATION, MAINTENANCE and
SAFETY MANUAL

For Hydrostatic Drive Units
with Standard Spread Hopper,
2WD and 4WD

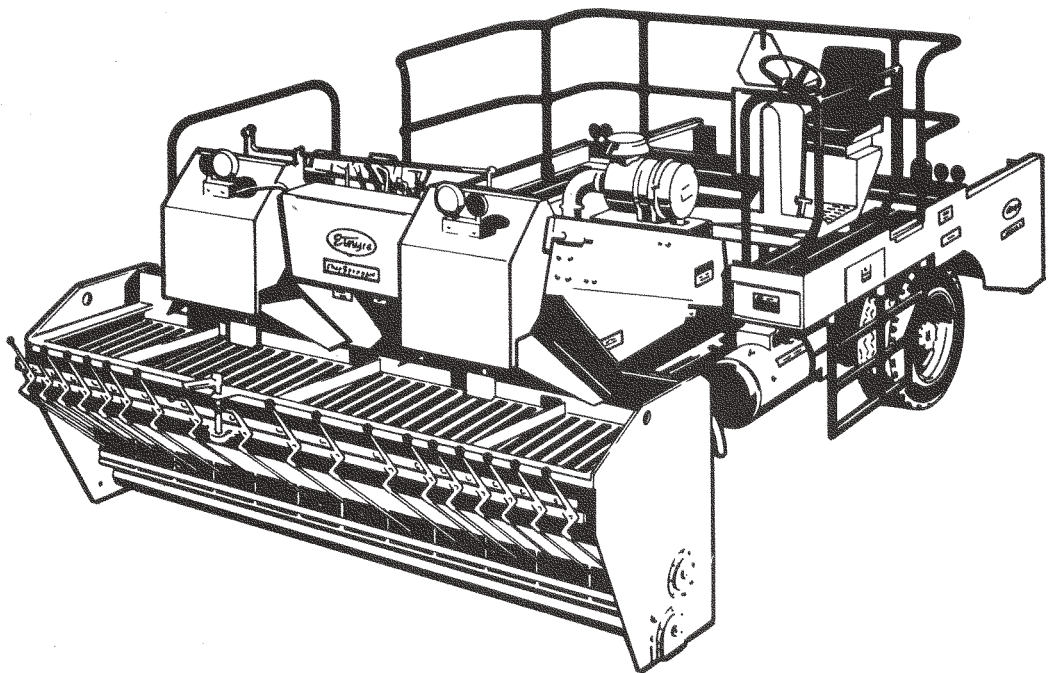

⚠ WARNING

Stay off hopper when machine is in motion.
Machine movements could cause a fall
resulting in injury or death.

E.D. ETNYRE & CO., Oregon, Illinois 61061

It is especially important from the safety standpoint that this manual be thoroughly read and understood before performing any operational or maintenance function.

⚠ CAUTION

- ⚠ Make certain everyone is clear of machine before starting engine or operation.**
- ⚠ Always use steps, platforms and handrails provided.**
- ⚠ Remain clear of moving or rotating parts.**
- ⚠ Always have shields, covers and guards in place when operating.**
- ⚠ Keep loose clothing away from conveyor area when operating conveyors.**
- ⚠ Always install locking control box cover and chock wheels when leaving machine unattended as protection against vandalism and accidental movement.**
- ⚠ Before operating the chipspreader, make an inspection of the machine to be sure that the machine is in a safe condition to operate.**
- ⚠ The seat must always be latched during travel.**
- ⚠ To avoid potential damage to electrical components disconnect batteries before welding.**
- ⚠ Since all functions except power steering and brakes are electrically controlled, turning the ignition key to "off" results in an emergency stop.**

⚠ WARNING

- ⚠ Unsafe operation of equipment may cause injury.**
Read, understand and follow the manuals when operating or performing maintenance.
- ⚠ Remain clear of all moving parts.**
- ⚠ The fuel tank is part of the crosswalk. Do not drill or weld in this area.**
- ⚠ Never put hands in between gate and spread roll or gate and rear of hopper. The gate could move at any time and cause severe injury.**
- ⚠ Do not travel with the seat unlatched. Seat movement could occur causing disorientation and possible loss of control.**
- ⚠ Shift in and out of "travel" only while stopped or moving at a very slow rate of speed. Shifts between "2nd" and "travel" are very abrupt and could cause personal injury.**
- ⚠ When two people are required to perform adjustments or maintenance operations or two people are simultaneously performing different operations, the work must be coordinated between the two people to avoid possible injuries.**

⚠ IMPORTANT

- ⚠ Do not tow the chipspreader before reading the towing instructions contained in this manual. Improper towing may damage the hydraulic motors.**

CHIPSPREADER OPERATION, MAINTENANCE AND SAFETY MANUAL

For Hydrostatic Drive Units

M-209-91

Units with Serial Numbers K-5126 and After

Standard Hopper,
2WD and 4WD Units



E.D. ETNYRE & CO., Oregon, Illinois 61061-9705

1333 South Daysville Road • Phone 815/732-2116 • Fax 815-732-7400 • Cable "EDECO"
Telex: RCA 249-415

TABLE OF CONTENTS

SAFETY

Safety Precautions	Inside Front Cover	
Reporting Safety Defects		3
Caution & Instruction Plates, Identification and Location		44

INTRODUCTION

Introduction and General Operating Procedures		3
General Identification of Unit Components		4

INITIAL START-UP

Machine Check Out		5
Attaching Hopper To Unit		5
Important Stopping and Brake Characteristics		6
Truck Hitch and Tow Bar Arrangement		43

IDENTIFICATION AND OPERATION OF CONTROLS

Conveyor Selector Switches		14
Control Box, Front End Man		14
Fuses		8
Gate Opening Set		8
Gate Override Pushbuttons		14
Gate/Spread Roll Switch		10
Hitch Release Pushbutton		12
Hitch Height Switch		14
Ignition/Power Switch		7
Instrument Panel, Digital		9
Lights and Turn Signals		11
Mode Selector, Manual/Park/Auto		8
Override Pedal		10
Seat Shift Switch		11
Speed Set, Auto		8
Speed Controller, Auto		13
Speed Range Selector		12
Speed/Direction Control Handle		10
Spread Roll Switch		10
Temperature Display, Hydraulic Oil		9, 11
Throttle Switch		12

OPERATION

Agitator, Hopper		20
Backup Alarm		18
Brake and Stopping Characteristics		6
Conveyor Controls, Automatic		18
Conveyor Belt Speed Controls		18
Conveyor Gate Adjustment, Rear		17
Control Box Adjustment		18

Differential Lock, Rear		19
Differential Lock, Front/Rear		19
Horn		18
Operating Procedures, General		3
Operating Range Charts		
Cat 3208, 142 HP Engines		21
Cat 3208, 165 HP Engines		22
Cat 3208T, 219 HP Engines		23
Cummins 6BT, 150 HP Engines		21
Cummins 6BTA, 190 HP Engines		22
Cummins 6CT, 210 HP Engines		23
Cummins 6CTA, 234 HP Engines		24
Seat Assembly, Powered		19
Segregation Screen		20
Speed/Gate Opening Selection		15
Tilt Wheel		18

MAINTENANCE & ADJUSTMENTS

Brake Adjustment		
Front		35
Rear		36
Front Brake Pressure Reducing Valves		32
Conveyor Belt Adjustment		26
Conveyor Relief Valves		28
Hitch Relief and Pressure Reducing Valves		31
Hopper Gate Adjustment		33
Hopper Gate Linkage Adjustment		26
Hopper Gate Wear Plate		25
Hopper Gate Relief Valves		28
Hopper Flow Gate, Rear Hopper		25
Hydraulic Control Pressure Relief Valve		29
Hydraulic System Start-Up Procedures		32
Lubrication Chart		42
Override Pedal Adjustment		37
Pressure Chart, Relief Valve Settings		41
Relief and Reducing Valve Pressure Adjustments		27
Relief Valve, Rear Hydraulic Pump		33
Steering Relief Valve, Power Steering		29
Seat Chain Adjustment		39
Seat Speed Adjustment, Powered Seat		37
Spread Roll Wear Plate		25
Spread Roll Relief Valves		27
Tachometer Calibration		37
Towing Instructions		39

INTRODUCTION

The Etnyre Hydrostatic chippersreader has been designed to improve the accuracy of chippersreading while improving productivity. This has been done by incorporating superior speed keeping capabilities and precise gate opening control.

It is especially important from the safety standpoint that this manual be thoroughly read and understood before performing any operational or maintenance function.

The information contained in this manual will enable you to better understand the operation and performance of the machine and thus better utilize it to obtain maximum performance from your chip-spreaders.

WARNING

Unsafe operation of equipment may cause injury. Read, understand and follow the manuals when operating or performing maintenance.

IMPORTANT

1. The optional front hopper segregation screen should be up when the unit is traveling between job sites to avoid possible damage to the screen.

2. Keep machine on road or relatively uniform surface at all times to avoid loss of traction and/or possible damage to the front hopper or rear of conveyors.

3. Place truck gearshift in neutral as soon as the truck is connected to the spreader.

4. Under most operating conditions the Chip-spreaders should be allowed to tow the truck. However, certain steep upgrade or downgrade conditions may require the truck to assist the chippersreader. The chippersreader **must not** be in neutral but **must** be attempting to maintain the set speed with the truck coordinating as near as possible.

5. Do not tow the chippersreader before reading the towing instructions contained in this manual as this may damage the hydraulic motors.

6. Never use the chippersreader to dislodge a truck or other equipment which has become stuck in mud or soft shoulder conditions as this may cause damage to the hitch, which could fail later in normal operation.

7. Avoid roading the machine with material in the hoppers if at all possible: Added weight in either hopper increases stopping distance, and weight in the front decreases available traction at the rear wheels.

8. After changing filters or working on the hydrostatic system, be sure to follow hydrostatic start up procedure to reduce the potential for damage to the hydrostatic system.

9. Always install locking control box cover and chock wheels when leaving machine unattended as protection against vandalism and accidental movement.

10. Before operating the chippersreader, do an inspection of the machine for condition of the tires, fluid leaks, fluid levels, fuel level, loose bolts, improper hose routings etc. Be sure that the machine is in a safe condition to operate.

REPORTING SAFETY DEFECTS

If you believe that your vehicle has a defect which could cause a crash or could cause injury or death you should immediately inform the National Highway Traffic Safety Administration (NHTSA) in addition to notifying E. D. Etnyre & Co.

If NHTSA receives similar complaints, it may open an investigation, and if it finds that a safety defect exists in a group of vehicles, it may order a recall and remedy campaign. However, NHTSA cannot become involved in individual problems between you, your dealer, or E. D. Etnyre & Co.

To contact NHTSA, you may either call the Auto Safety Hotline toll-free at 1-800-424-9393 (or 366-0123 in Washington, D.C. area) or write to: NHTSA, U.S. Department of Transportation, Washington, D.C. 20696. You can also obtain other information about motor vehicle safety from the hotline.

GENERAL IDENTIFICATION

- 1 Conveyor Drive Assembly
- 2 Hydraulic Oil Coolers
- 3 Front Hydraulic Pump - Component System
- 4 Driveline - Hydraulic Pump
- 5 Power Gate Opener
- 6 Spread Roll Control Valve
- 7 Front Wheel Drive Motors-4WD
- 8 Front Axle ASM
- 9 Return Manifold
- 10 Filter - Return Line
- 11 Filter - Return Line
- 12 Reservoir - Hyd, Component System
- 13 Rear Hydrostatic Pump - Drive System
- 14 Reservoir - Hyd, Drive System
- 15 Filter - Suction
- 16 Hydrostatic Control Assembly
- 17 Rear Wheel Drive Motors
- 18 Conveyor Tail Pulley
- 19 Spread Hopper Gates
- 20 Lights
- 21 Conveyor Deflectors
- 22 Covers - Conveyor and Engine
- 23 Conveyor Control Valves
- 24 Air Filter ASM
- 25 Control Console

- Power/Ignition Switch
- Mode Selector - Manual/Auto
- Auto Speed Set
- Gate Opening Set Point
- Fuses
- Digital Instrument Panel
- Control Handle
- Gate/Spread Roll Switch
- Override Pedal
- Turn Signals, Hazard Flasher
- Headlights
- Hydraulic Tank Temperature Display
- Seat Shift
- Hitch Release
- Throttle Switch
- Speed Range Selector
- Auto Speed Controller
- Conveyor Control Selectors
- Hitch Height Switch

- 26 Operator Seat ASM
- 27 Rear Deck Sections
- 28 Conveyor Flow Deflectors
- 29 Conveyor Flow Regulator Gates
- 30 Receiving Hopper
- 31 Truck Hitch
- 32 Fuel Tank
- 33 Conveyor Head Pulley
- 34 Spread Hopper
- 35 Segregator ASM
- 36 Gate Actuating Lever ASM
- 37 Hopper Material LVL Mechanism
- 38 Power Seat Motor
- 39 Brake Actuator, Front Brake Reservoir
- 40 Power Steering Motor
- 41 Motor Shift Valves
- 42 Override Pedal
- 43 Hitch Raise Cylinder
- 44 Brake Cylinder

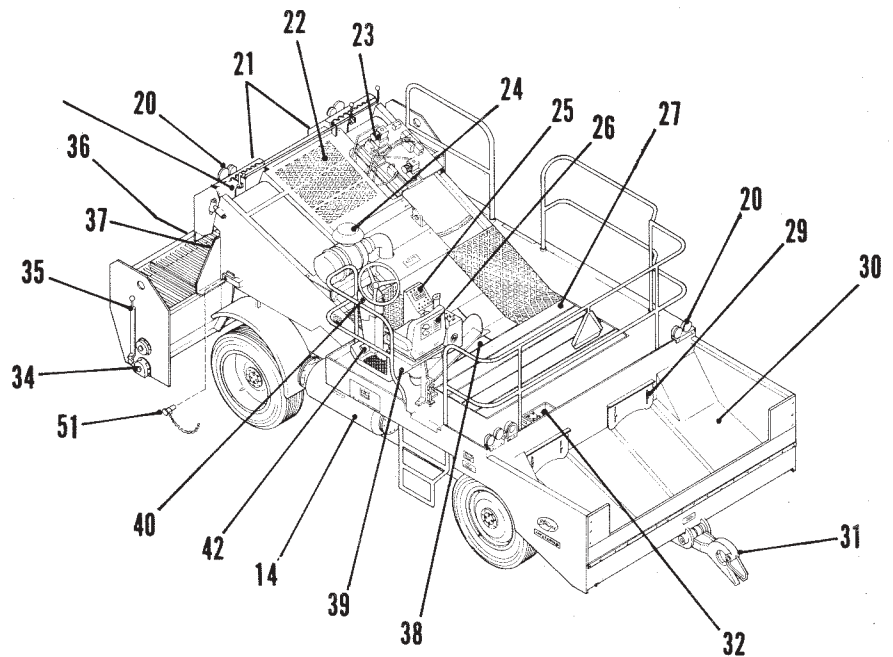
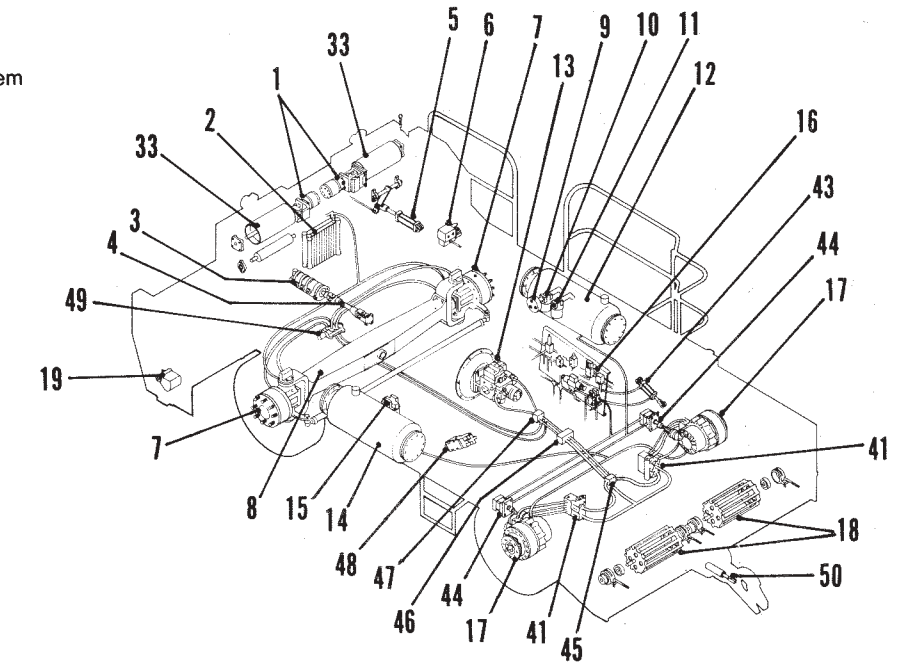

- 45 Rear Differential Lock (optional)
- 46 Front/Rear Differential Lock Valve (optional)
- 47 Shuttle Valve
- 48 Radar Speed Sensor
- 49 Valve - Front Drive Motors (optional)
- 50 Hitch Release Cylinder
- 51 Hopper Latch Pin

INITIAL START-UP

CHECK OUT

1. The following accessories are shipped with each chipspreader: grease gun, extra linkage rods for shortened truck hookup, agitator disconnect bolt, parts book and operation, maintenance and safety manual, engine parts and operator's manual.

2. Best performance for most operating conditions is achieved when tire pressures are set to 55 to 60 PSI in front and 60 to 65 PSI in rear. However, various operating speeds, road bed conditions, truck pulling arrangements and other operating conditions may require different tire pressures.

3. Grease all fittings and check all reservoir oil levels in accordance with the Chipspreader Lubrication Chart on rear of seat back prior to operation.

4. Check engine coolant and oil levels prior to operation. Refer to engine operator's maintenance manual for complete engine service requirements.

ATTACHING HOPPER TO UNIT

Safety Precautions

Before lifting hopper, check to ensure that adequate clearance will be maintained between the lifting machine and overhead electrical line. You must maintain at least 10 feet of clearance.

Ensure that the hopper is well secured and rigged before starting any lifting operation.

Ensure that the area around the hopper is clear of personnel and equipment and only trained personnel are used to assist in installing the hopper.

Never let anyone go under the hopper while it is suspended.

Ensure that hands and feet are kept clear of the hopper and potential pinch points on front of the chipspreader during installation.

1. By hooking a lifting sling into the rear lifting eye, the hopper can be tilted forward while being raised, allowing the hopper carrying shafts to engage the hopper carrying arms on the chipspreader. (Fig-

ure 1 & 2) Lower hopper slowly until lifting sling can be disconnected.

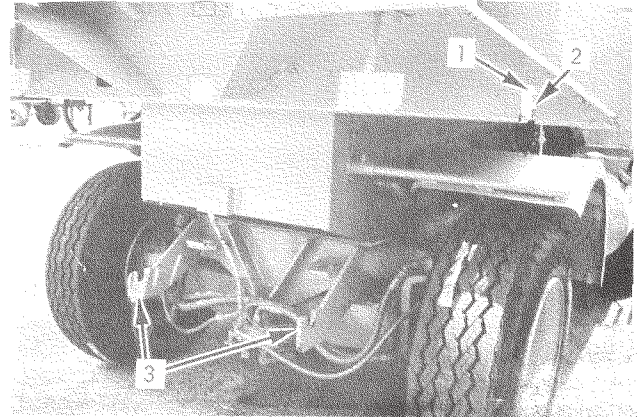

Figure 1.
1. Pin Catch 2. Hopper Pin 3. Carrying Arms

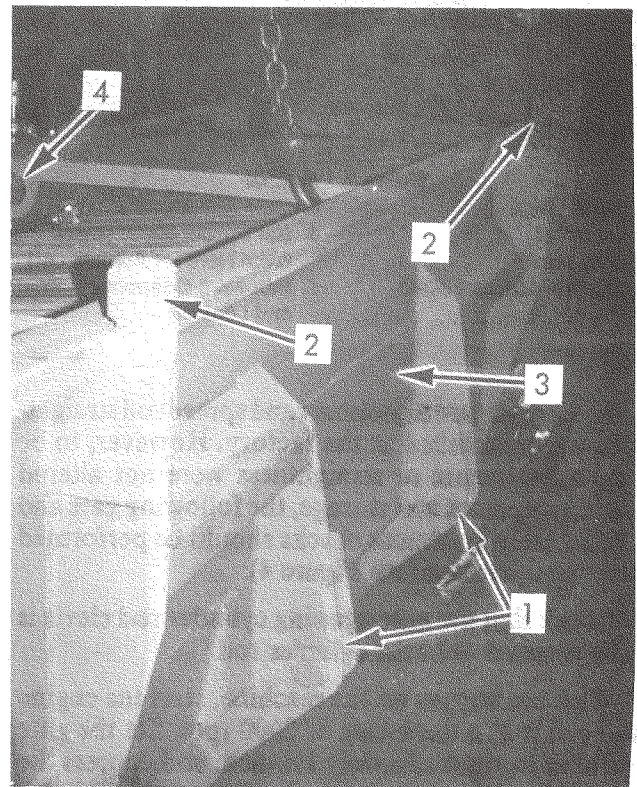

Figure 2.
1. Carry Shaft 3. Hopper
2. Latch Arms (2) 4. Front Lifting Attachment

2. Attach lifting device to front lifting attachment and raise hopper to vertical position.

3. Install hopper pins, in front of latch arms, through pin catch.

4. Always install latch pin lock pins and snap down rings properly prior to releasing the lifting device.

5. Uncouple spread roll hoses and couple to hopper drive motor hoses. Use caution to wipe each half of each connector clean before connecting. *Dirt and contaminants can cause major damage to the hydraulic systems.*

6. Attach the hopper reach rod (see Figure 3).

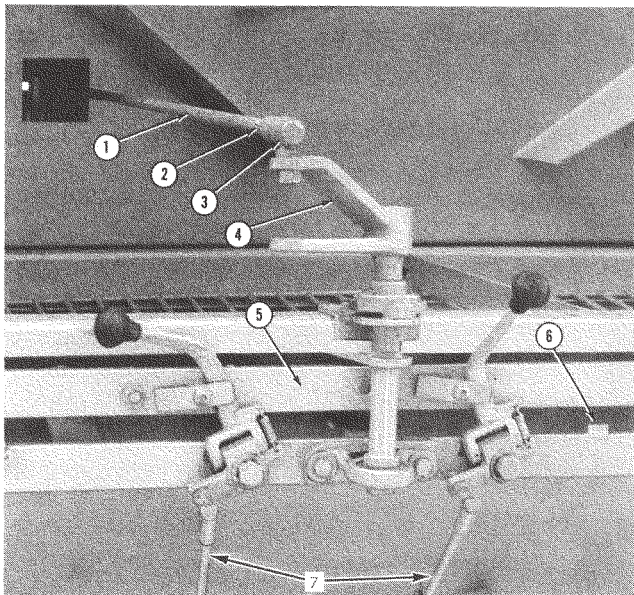

Figure 3. Hopper

- | | |
|--------------------------|---|
| 1. Reach Rod | 5. Gate Actuator Bar |
| 2. Jam Nut | 6. Bar Spacer Block (Insert Shim Here for Adjustment) |
| 3. Ball Joint | 7. Ball Joint Connector and Locknut |
| 4. Control Arm and Shaft | |

7. Hopper gate adjustment and spread roll straightness are established at the factory. However, to be sure adjustments or straightness were not altered during shipment and storage, the following gate and spread roll adjustment checks should be performed prior to operation (see Figure 4):

Check that the gate opening cylinder rod clevis is fully screwed onto the cylinder rod.

With the hopper on the machine, start the engine and run it at a minimum of 2000 rpm. Set the gate opening to approximately 1½ inch, and depress the right side of the “gate/spread roll” switch.

Depress the override pedal fully (Figure 5). With the override pedal fully depressed, there should be 1/16” clearance between the gate and the spread roll.

Release the override pedal and depress the left side of the “gate/spread roll” switch. There should be 1/16” clearance between the gate and the spread roll. If this clearance is not constant across the full

width of the hopper, it indicates that the spread roll is not straight. Contact the factory for straightening instructions.

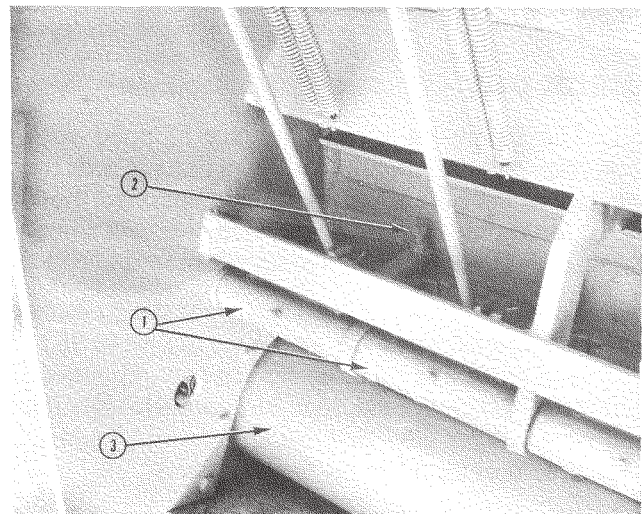

Figure 4. Hopper Gates

- | | | |
|----------|---------------------|----------------|
| 1. Gates | 2. Adjustment Bolts | 3. Spread Roll |
|----------|---------------------|----------------|

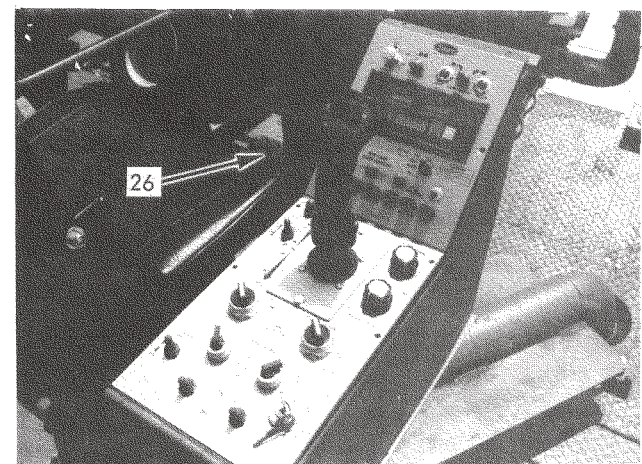

Figure 5. Override Pedal Location

26. Override Pedal

! IMPORTANT

1. While the Chipspreader is designed to operate on new sealcoat surfaces, all dynamic braking is being done by the hydrostatic system. With abrupt control inputs it is possible to scuff the surface during starting or stopping. However, with smooth application of control inputs very precise accelerations and decelerations can be made giving the ability to out-perform a conventional clutch/brake/gear combination.

2. These characteristics on both new sealcoat surfaces and other surfaces vary considerably. Therefore stopping distances must be watched carefully, particularly when towing a truck, going downhill or in stopping from higher travel speeds.

3. The larger the truck or steeper the grade, the longer the stopping distance.

4. Travelling with the front hopper loaded removes weight from the rear wheels thus reducing the braking effectiveness of the rear motors while the additional weight increases the braking forces required. Carrying material in the rear hopper also increases the braking forces required and consequently increases the required stopping distance from a given speed. It is therefore highly recommended to travel or "road" the machine in an empty condition if at all possible.

5. When operating with the truck, in some cases—for instance on steep downgrades, the truck should assist in braking. The truck should always set its own brakes after stopping, regardless of whether the

combination is stopped on a downgrade, upgrade or level. The braking effort must be a coordinated effort when required. It is therefore important to have a clearly understood means of communication between the chipsreader and truck. This may be done by radio, hand signals, horns etc. Each truck driver should know who is to give signals, if it is by signal, where to look for the signal and the meaning of each signal.

Identification and Function of Controls Refer to Figure 6 for identification of the following descriptions.

1. Power/Ignition Switch.

Rotating from "off" to "on" supplies electric power to all systems and controls. Rotating the

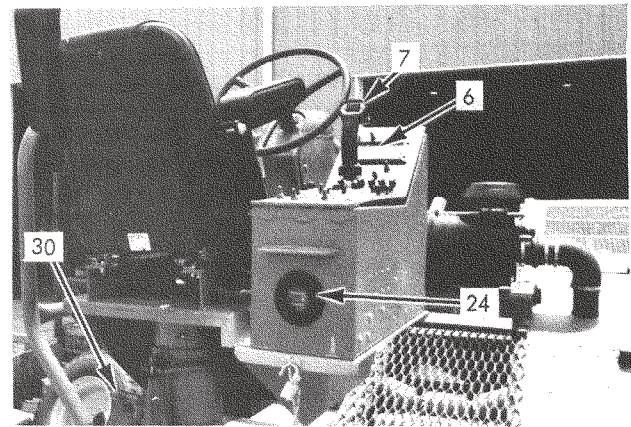
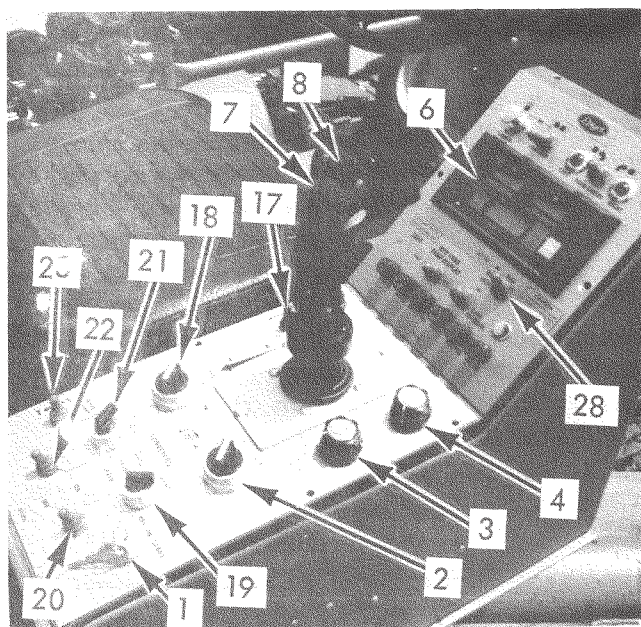
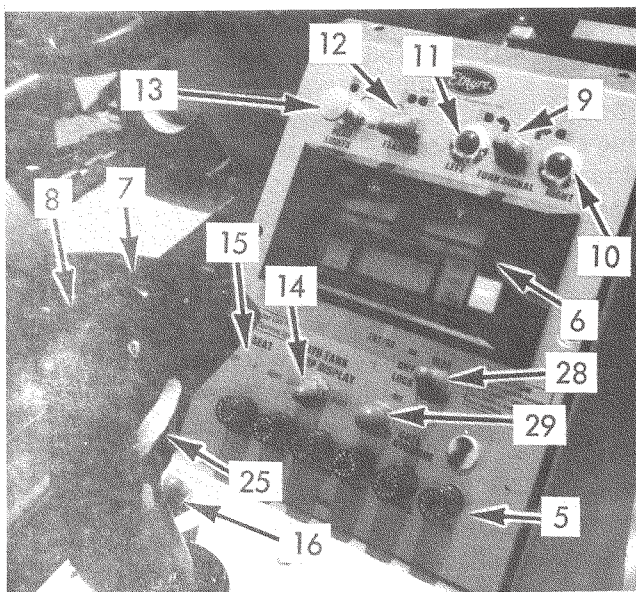

Figure 6. Control Console Identification

1. Power/Ignition Switch
2. Mode Selector - Manual/Park/Auto
3. Auto Speed Set - Potentiometer
4. Gate Opening Set Point
5. Fuses
6. Digital Instrument Panel
7. Manual Speed/Direction Control Handle
8. Gate/Spread Roll Switch
9. Turn Signal Selector
10. Right Turn Signal Indicator
11. Left Turn Signal Indicator
12. Hazard Flasher Switch
13. Headlight Switch
14. Hydraulic Tank Temperature Display Selector
15. Seat Shift Switch (optional)
16. Hitch Release Pushbutton
17. Throttle Switch
18. Speed Range Selector
19. Right Conveyor Control Selector
20. Right Conveyor On/Off Switch - Driver's
21. Left Conveyor Control Selector
22. Left Conveyor On/Off Switch - Driver's
23. Hitch Height Switch
24. Hourmeter
25. Horn (on trigger)
26. Override Pedal
27. Auto Speed Controller (internal. At front of box.)
28. Optional Differential Lock Switches
29. Gate Override
30. Seat Lock Pin

switch further to the right against the spring will engage the starter. When the engine runs, release the key and the switch will remain in the “on” position. *Since all functions except power steering, rear brakes and front brakes (2wd only) are electrically controlled, turning the key to “off” results in an emergency stop.*

⚠ WARNING

Turning ignition key to “off” results in emergency stop.

2. Mode Selector—Manual/Park/Auto.

A three position switch selects either “manual” or “auto” operation with a “park” position in between.

⚠ CAUTION

Mode of operation should be selected with machine stationary.

In “manual” mode, speed and direction are controlled by the handle.

In “auto” mode, **only forward direction is available.** The handle must be moved forward only a few degrees to engage the auto controller. Further forward movement has no effect. When in auto, speed is set by the auto speed potentiometer alongside the handle.

Mode of operation should be selected with machine stationary.

If the selector is moved from “manual” to “auto” while moving, the chippers will come to a rather abrupt halt and then accelerate to the speed set by the “auto speed set” knob or the highest speed possible in the range selected—whichever is lower.

If the selector is moved from “auto” to “manual” while moving, the pump control will switch from the displacement commanded by the “auto speed set” knob to that commanded by the position of the manual handle. If the two are not nearly matched, an abrupt speed change will occur.

In either case the command signal will be momentarily disconnected from the pump and the rear parking brake will momentarily be applied during the attempted shift from manual to auto or vice versa. This will cause a very abrupt stop and could cause bodily injury.

3. Auto Speed Set—Potentiometer.

When in the “auto” position, this potentiometer provides the command signal (or set point) to the

automatic controller. This potentiometer control should be set to the desired vehicle speed in feet per minute. The digital readout will display the actual feet per minute. Once the speed is set and the actual speed is confirmed, the chippers will repeat that speed any time “auto” is engaged with the range selector in the proper displacement for that speed (i.e. the “auto speed set” is set for 700 fpm; you must have the speed range control in “chip” in order to reach 700 fpm. The automatic controller will bring the chippers up to and maintain the set speed of 700 fpm).

As noted under “Speed Range Control” the maximum speeds recommended in “auto” are approximately 15% lower than those available in manual. These lower speeds allow the automatic controller to have enough pump stroke left to compensate for normal engine governor droop. As an example—if a current Etnyre chippers (Eaton 4005A transmission and Spicer PR1300 axle) were operated in 2nd hi, the normal speed would be 346 fpm. However, when a hill is encountered, the increased load on the engine will cause the governor to allow the engine speed to decrease as much as 10% and the ground speed will fall to 311 fpm. Conversely when going downhill, the governor would allow the engine to increase speed by as much as 10% (although usually somewhat lower) thus the ground speed could become as high as 381 fpm.

The hydrostatic chippers when in the manual mode results in less than a 10% decrease or increase in vehicle speed, but it still has similar speed characteristics.

When the hydrostatic chippers is operated in the “auto” mode, 15% lower recommended speeds allow the controller the added capacity to make up the engine decrease or increase in speed. When the hydrostatic chippers is operated at a speed of 330 fpm in “lo” range it will typically maintain its speed within 5 to 6 fpm.

This is possible up to full engine HP available. If the required HP exceeds the available, the chippers will slow down and then recover to the preset speed as load (HP required) decreases.

4. Gate Opening Set Point.

This control sets the position to which the gates will open. The set point is the actual position, in inches, that the gates will open to when the gate/spread roll switch (Ref. 8, Figure 6) is activated.

5. Fuses.

Light fuse: Supplies power to all lights except brake lights.

Horn fuses: Supplies power to the horn, the hitch release, the hitch height control, the gate opener valve, and the engine throttle.

Conveyor fuse: Supplies power only to the conveyors.

Power fuse: Supplies power to the manual control handle, the auto speed controller, the magnetic pickup the brake lights, the backup alarm and the brake release valve.

Motor fuse: Supplies power to the rear motors, the front motor disengagement valve, and also the powered seat valve.

Gate fuse: Supplies power to the gate control board and the spread roll valve.

6. Digital Instrument Panel. (Fig. 7)

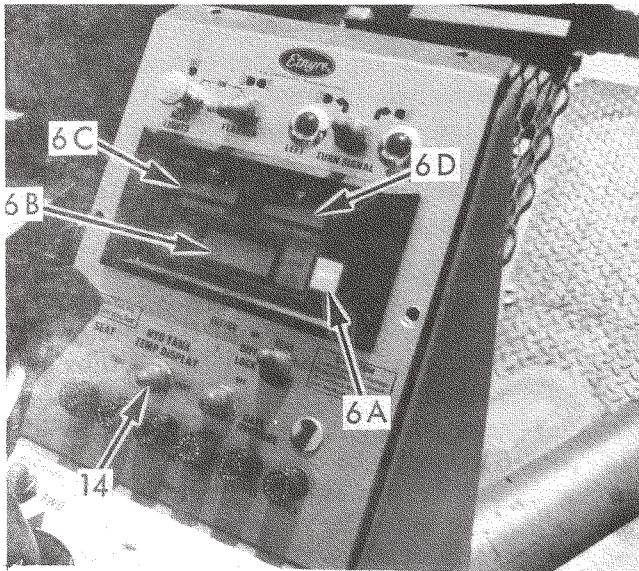

Figure 7. Digital Instrument Panel

- | | |
|----------------------------------|---|
| 6A. Select Switch | 6D. Engine Coolant Temperature Bargraph |
| 6B. Digital Display Area | 14. Hydraulic Oil Temperature Tank Selector |
| 6C. Engine Oil Pressure Bargraph | |

All instrumentation is included in the digital/ bargraph panel. The left bargraph displays engine oil pressure. The right bargraph displays engine coolant temperature. The digital display area displays the following items: feet per minute, engine RPM, battery voltage, hydraulic oil temperature (selectable left or right tank) and fuel level. The displayed item is selectable by pressing the “select” area (6A) on the display. Pushing “select” once will cause the display to change from the current item to the next in the order. Pressing “select” again will change the display to the next item, etc. When hydraulic oil temperature is selected, toggle switch (14) is used to select which tank temperature is to be displayed.

An alarm function is built into the instrument panel. If an item sensed by the display reaches its built in alarm condition, the appropriate word will appear and flash regardless of what item is currently selected and displayed. In addition, an output is sent to the buzzer and also to the warning light mounted below the steering wheel hub. For instance, the normal use will be to have speed (FPM) on display—this will automatically be displayed on starting the engine. If the fuel level gets down to the alarm level (approximately 15% or 10½ gallons), the word “fuel” will flash in its location within the display, the buzzer will sound and the warning light below the steering wheel will come on, and the FPM will continue to be displayed. The same is true for any of the items monitored which have alarm points. The alarm points are as follows:

low oil pressure	8 PSI
high water temperature	220 F
low fuel	15%-10 Gal.
high hydraulic oil temp.	180 F.

Note: There are two tanks selected by the selector switch (Ref. 14, Figure 7). **Only the tank selected will be connected to the alarm.** It is therefore important to occasionally switch the selected tank to monitor its condition. The selector switch should normally be kept on the left (hydrostatic) tank, even though while chipping it normally runs cooler than the right (implement) tank. The reason for this is the relative costs of the components is much greater on the hydrostatic system. When travelling the hydrostatic oil temperature runs hotter and **the switch should always be on the left during travel.**

When chipping, the right tank should be selected for about 15 seconds minimum every 30 minutes or so. If the right tank is above 180 degrees F. the alarm will come on and “oil temp” will flash as well as the red light below the steering wheel. It is not necessary to display oil temperature to connect the monitor system to the right tank, but you may wish to view the actual temperature. After checking the right tank be sure to return the switch to the left tank.

The tachometer is digitally displayed to the nearest 10 RPM. There are 4 calibrations built into the display for different engines. The proper calibration is factory set and should not have to be reset except if the Chipspreader batteries are disconnected. The calibration procedure is covered under the adjustment section.

A digital readout of speed, reading to the nearest foot per minute, is provided. The display uses a ground speed radar (Figure 8a) to generate pulses. The pulses are fed to both the automatic speed controller and a conditioning circuit which then feeds the signal to the digital display.

7. Manual Speed/Direction Control Handle. (Figure 8)

The control handle provides both direction, (forward, neutral, reverse) and rate of speed when in the "manual" mode. In addition to controlling speed and direction in the "manual" mode, the handle provides on/off of the auto function when in the "auto" mode.

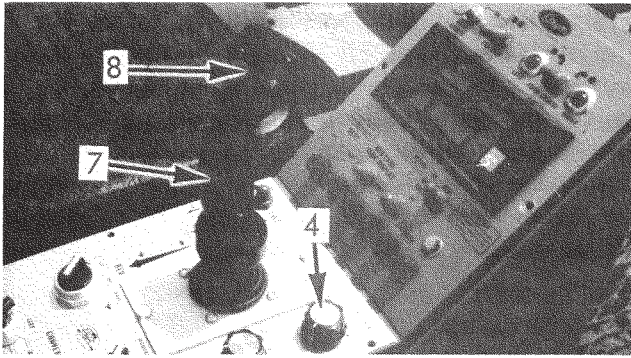

Figure 8. Speed/Direction Control Handle

- 7. Manual Control Handle
- 8. Gate/Spread Roll Switch
- 4. Gate opening Set Point

The handle also incorporates a neutral safety start switch, automatic application of the rear brakes and brake lights when placed in neutral, and activation of the back up alarm. These functions occur regardless of mode of operation (i.e. "auto" or "manual"). The handle has a detent in the neutral position and an adjustable friction drag for holding at any desired position other than neutral.

Decelerating is accomplished by moving the handle toward neutral. The pump displacement control follows the handle position with no lag, therefore smooth adjustments in speed are recommended, but rapid speed changes including coming to a complete halt may be accomplished with care. Extremely rapid decelerations will cause the hydrostatic system to reverse the high and low pressure sides of the loop and can raise the pressures to the relief valve setting and should be avoided. Upon reaching the neutral position of the handle, the rear brakes will be automatically applied. They will lock the wheels upon very rapid control handle movement into neutral from higher travel speeds, therefore the recommended procedure is to use the override pedal when stopping, returning the control handle to neutral immediately upon reaching a complete stop, thereby applying the rear brakes. Operation of the override pedal will be explained later in this description.

With the mode selector in "auto," the control handle will operate as follows: moving the handle rearward out of the neutral position approximately 3 degrees will activate the optional backup alarm and release the brakes. *The chipspreader cannot be operated in reverse while in "auto."* Moving the

handle forward out of the neutral position approximately 3 degrees will release the rear brakes and engage the command signal circuit: the "auto" circuit will accelerate the chipspreader to the preselected speed at a non-adjustable rate. Acceleration and deceleration should be modulated by the override pedal which will be explained under that title heading (26). The speed range control must be appropriately set in order to reach the desired speed. Further displacement of the control handle will have no additional effect. Adjustments to speed are made using the "Auto Speed Set" potentiometer.

Stopping is accomplished by smoothly depressing the override pedal fully and returning the handle to neutral.

8. Gate/Spread Roll Switch. (Figure 8)

The rocker switch activates the spread roll and also the command circuit for the gates. The gate opening is set by the gate opening set point (4) to the desired opening. The gates are then opened or closed with the rocker switch. Depressing the left side of the switch closes the gates, while depressing the right side opens the gates. When used this way the gates will go from closed to the preset opening or from the preset opening to closed.

If a gradual opening of the gates is desired in conjunction with starting the machine traveling forward, depress the right side of the spread roll switch while keeping the override pedal fully depressed and then release the override pedal to control acceleration. The gates will also open from the fully closed position to the setpoint of the gate opener set point potentiometer. A gradual closing may be accomplished by depressing the override pedal to decelerate the vehicle to a halt while leaving the right side of the rocker switch depressed. This will close the gates in conjunction with decelerating the machine. When the machine has come to a halt, depress the left side of the rocker switch while simultaneously returning the handle to neutral to keep the gates closed. Moving the control handle into neutral will keep the rear brakes set and disengage the speed and gate commands. Once the handle is in neutral and the left side of the spread roll switch is depressed, the override pedal can be released.

26. Override Pedal. (Figure 5)

The override pedal is used to accelerate and decelerate the chipspreader and can also be used to "feather" the front hopper gates closed or open. When the pedal is in the full up position, it has no effect on any of the other control settings. As the pedal is depressed toward the floor, it decreases the command signal from the set point toward zero and, when it is fully depressed, it reduces the given com-

mand signal to zero and applies the rear brakes and also the front brakes on a 2 WD machine. In effect it works like slipping the clutch on a mechanically driven machine, enabling the driver to have full control over the acceleration and deceleration of the machine. *However, unlike a mechanical machine, partial depression of the pedal does not cause any accelerated wear and can be used for unlimited time with no adverse effect.*

The normal operation in “manual” mode would be to depress the pedal fully, move the handle forward to approximately the desired position and then releasing the pedal smoothly to full up position. The rate of release of the pedal will control the acceleration of the vehicle up to the selected speed in either forward or reverse.

The normal operation in “auto” mode would be to depress the pedal fully, set the desired speed on the potentiometer, move the handle forward more than 3 degrees and then releasing the pedal smoothly to the full up position controlling the acceleration up to the set point. To stop, in either mode of operation, the procedure is reversed. Depress the pedal smoothly, controlling the deceleration to a full halt and keep the pedal fully depressed thus applying the rear brakes while returning the handle to the neutral position and depressing the left side of the gate/spreadroll switch to disengage the command signals and keep the rear brakes set and then the pedal may be released to the full up position.

If the gate/spread roll switch is engaged, the gate opening will follow the pedal up and down from zero to the preset position. Using the thumb switch will turn the gates on/off regardless of their position of the override pedal.

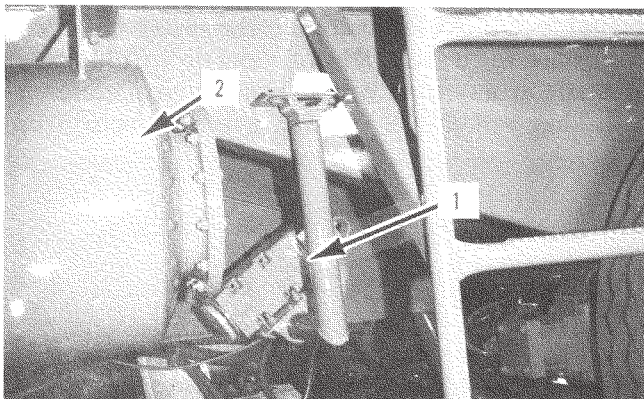

Figure 8a.
Ground Speed Radar Unit
1. Ground Speed Radar Unit
2. Left Side Hydraulic Tank

9, 10, 11. Turn Signal Selector and Indicators. (Figure 9)

12. Hazard Flasher Switch (Figure 9)

Push up for “on” and push down for “off.”

13. Headlight Switch (Figure 9)

Pull out for “on” and push in for “off.”

14. Hydraulic Tank Temperature Display Selector. (Figure 9)

The tank selected has its temperature displayed and is also connected to the alarm. *The tank which is not selected is not connected to the alarm.* It is recommended that the tank display be alternated between tanks for this reason. See digital instrument panel item No. 6.

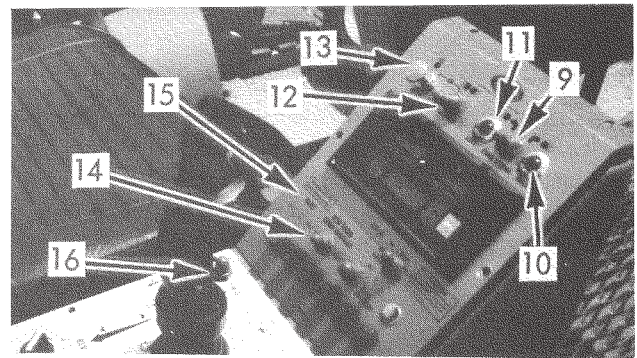

Figure 9. Control Panel

- | | |
|---------------------------------|---|
| 9. Turn Signal Selector | 14. Hydraulic Tank Temperature Display Selector |
| 10. Right Turn Signal Indicator | 15. Seat Shift Switch (optional) |
| 11. Left Turn Signal Indicator | 16. Hitch Release Pushbutton |
| 12. Hazard Flasher Switch | |
| 13. Headlight Switch | |

15. Seat Shift Switch.

CAUTION

The seat must always be latched during travel.

Before using be sure seat is unlatched. Hold switch right or left to move seat to desired position. The moving seat is meant to be an operator convenience during the chipping. This switch only receives power when the speed range selector is in either lo or chip. Before travelling the machine, the seat must be moved to either the full left or right position and the seat latch pin inserted into the lock socket in the deck of the vehicle. Failure to do this may result in

inadvertent movement of the seat assembly during acceleration and deceleration. *The seat must always be latched during travel.*

16. Hitch Release Pushbutton. (Figure 9)

Push the hitch release pushbutton to disengage the chispsreader from the supply truck. There must be some "slack" in the hitch (between the chispsreader and supply truck) in order for the latch to release. While pushing the hitch release pushbutton, one should momentarily depress the override pedal slightly to slow the chispsreader. This will cause the required "slack." The override pedal should then be released, while still depressing the hitch release pushbutton. Once the truck has separated from the chispsreader, the hitch release pushbutton can be released. A second hitch release pushbutton is provided for the front end man.

It is possible to stop with no "slack" in the hitch (between the chispsreader and supply truck). If this happens, the chispsreader must be backed up slightly to create the necessary "slack" and then driven forward while pushing the hitch release pushbutton.

In order to hook up to a supply truck, momentarily depress the hitch release pushbutton to open the hitch if it is not already open, and back into the truck. The hitch automatically locks when it is closed by pushing back on the truck.

17. Throttle Switch. (Figure 10)

Push forward to increase engine RPM, push rearward to decrease RPM. Under certain conditions it may be desired to have an intermediate RPM setting, however, *the hydrostatic system is designed to be run with the engine running at full governed RPM.* Therefore whenever chipping at normal spreads (i.e. anything over 80 FPM) the engine should be run at governed RPM.

18. Speed Range Selector. (Figure 10)

A three position switch selects the vehicle speed range by changing the rear motors' displacement from large to intermediate the disengages the front wheels for the travel range. On optional powered seat swing equipped units, this switch also supplies power to the seat shift switch only in lo or 2nd.

The speed ranges are approximately:

Manual Operating Ranges

LO	2 WD	0-650 FPM (7.4 MPH, 11.9 KPH)
LO	4 WD*	0-650 FPM (7.4 MPH, 11.9 KPH)
2nd	2 WD	0-800 FPM (9.1 MPH, 14.5 KPH)
2nd	4 WD*	0-800 FPM (9.1 MPH, 14.5 KPH)
TRAV	2WD FWD	0-1650 FPM (18.8 MPH, 30.2 KPH)

TRAV 2WD REV 0-1050 FPM (11.9 MPH, 19.0 KPH)

TRAV 4WD* FWD or REV 0-1650 FPM (18.8 MPH, 30.2 KPH)

Actual Maximum Speed Possible

LO 2 WD 700 FPM (8.0 MPH, 12.8 KPH)

LO 4 WD* 700 FPM (8.0 MPH, 12.8 KPH)

2nd 2 WD 850 FPM (9.7 MPH, 15.5 KPH)

2nd 4 WD* 850 FPM (9.7 MPH, 15.5 KPH)

TRAV 2WD FWD 1750 FPM (19.9 MPH, 31.8 KPH)

TRAV 2WD REV 1100 FPM (12.5 MPH, 20.0 KPH)

TRAV 4 WD* 1750 FPM (19.9 MPH, 31.8 KPH)

Auto Operating Range

2 WD 0-700 FPM (8.0 MPH, 12.8 KPH)

4 WD* 0-700 FPM (8.0 MPH, 12.8 KPH)

* if so equipped

⚠ WARNING

Shift in and out of "travel" only while stopped or moving at a very slow rate of speed. Shifts between "2nd" and "travel" are very abrupt and could cause personal injury.

Since there are differences in operating characteristics between 2 and 4 WD machines, we will cover each in a separate paragraph below.

2 WD Only

The shift from "2nd" to "travel" should be made only after positioning the seat full left or full right and the latch pin inserted since electric power is not available to move the seat after the switch has been positioned to "travel." Upshifts and downshifts may be made at any time whether moving or standing still. They will always be smooth due to the orifices

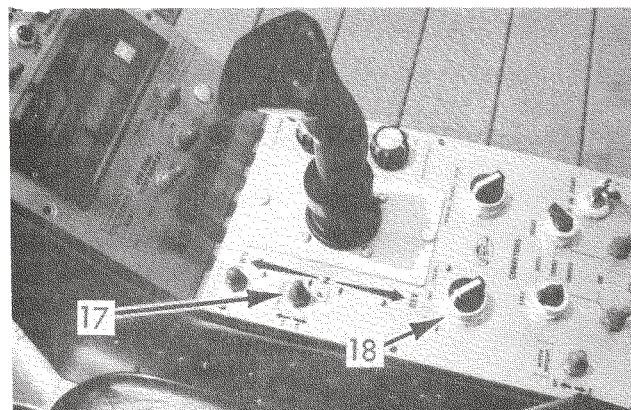

in the control system. Selection of speed range should be based on the desired operating speed—generally you should use the lowest speed range that will give the desired operating speed (i.e. if the desired speed is 500 FPM use “lo.” If the desired speed is 700 FPM use “2nd.” If additional torque is required to start off, use “lo” to get moving, and once moving, shift to “2nd.” The optional rear side/side diff lock may be used to reduce the possibility of rear wheel spin. Use “travel” only for moving the chippers by itself—**never attempt to pull a truck in “travel.”** The small displacement of the rear motors, necessary to get the higher travel speeds, will result in the pressure rising to the relief valve setting of 5000 PSI. If the oil goes across the relief valve it will be heated to temperatures which can destroy seals and cause damage to hydraulic components.

4 WD Only

The shift from “2nd” to “travel” should be made only after positioning the seat full left of right and the latch pin inserted since electric power is not available to move the seat after the switch has been positioned to “travel.” Upshifts and downshifts between “lo” and “2nd” may be made at any time whether moving or standing still. They will always be smooth due to the orifices in the control system. **A 4 WD machine should be shifted in and out of “travel” only while stopped or moving at a very slow rate of speed (i.e. under 100 FPM).**

The shift from “2nd” to “travel” disengages the front wheels to a free wheeling mode. The engagement valve must shift very quickly by necessity of function. This results in a rather abrupt shift which is particularly evident when high flow rates are in use. It also causes rather high pressure spikes to occur in the hydrostatic system which can cause eventual damage. **These upshifts and downshifts between “2nd” and “travel” are very abrupt and could cause personal injury.**

⚠ WARNING

Upshifts and downshifts between “2nd” and “travel” are very abrupt and could cause personal injury.

Selection of speed range should be based on the desired operating speed—generally you should use the lowest speed range that will give the desired operating speed (i.e. if the desired speed is 650 FPM or less, use “low”). If the desired operating speed is 700 FPM use “2nd.” If additional torque is required to start off, use “low” to get moving and, once moving, shift to “2nd.” When operating in “lo” there is more torque available and the torque split is 50/50

allowing the use of the optional front/rear diff lock in addition to the optional rear side/side diff lock, thus reducing the possibility of wheelspin. Use “travel” only for moving the chippers by itself—**never attempt to pull a truck in “travel.”** The small displacement of the rear motors alone, necessary to get the higher travel speeds, will result in the pressure rising to the relief valve setting of 5000 PSI. If the oil goes across the relief valve it will be heated to temperatures which can destroy seals and cause damage to hydraulic components.

27. Auto Speed Controller. (Figure 6)

The same ground speed radar (Figure 8a) that feeds a signal to the conditioning circuit for the digital display (6) also feeds its signal to the automatic speed controller. The automatic speed controller compares the feed back signal to the desired speed as set by the auto speed set point (3).

The auto speed controller is all contained on a single printed circuit board. It has three trim adjustments which have been factory preset for the unit and normally should not need adjustment in the field.

Normal spreading operation in auto would be done as follows:

- a) Put the auto/manual selector in “auto.”
- b) Place the control handle in neutral.
- c) Set the desired speed on the auto speed set. (3)
- d) Set the speed range selector (18) appropriately (“lo” or “chip”) to reach the desired speed.
- e) Turn the gate/spread roll switch (3) “off.”
- f) Set the desired gate opening on the gate set point. (4)
- g) Depress the override pedal (26) fully.
- h) Push speed/direction control handle (7) forward more than 3 degrees.
- i) Release override pedal (26) smoothly and slowly until fully up.
- j) Upon reaching the starting line of spreading, depress the right side of the gate/spread roll switch (8) fully to turn the gates “on.”
- k) Upon reaching the ending line, center or depress the left side of the gate/spread roll switch fully (8) to shut the gates “off.”
- l) Depress the override pedal smoothly to the fully depressed position.
- m) Return the control handle to neutral.
- n) Release the override pedal.

Speed changes may be made while moving by rotating the auto speed set point (3) smoothly to the new speed. The chippers will change speed to the new speed. The gate opening set point (4) will then have to be reset to a new opening to compensate for the new speed in order to maintain the desired spread rate.

19. Right Conveyor Selector (Figure 11)

In the rearward position, power is supplied to the driver's "on/off" selector switch (20) allowing the driver to turn the conveyor "on" or "off."

In the center position power is supplied to the front end man's "on/off" selector switch allowing the front end man to turn the conveyors "on" or "off."

In the forward position, power is supplied to the auto paddle switch mounted below and along the inboard side of the conveyor hood. (See Fig. 15) When this switch is tripped by material moving the paddle, the conveyor will shut off and conversely when it is untripped by a lack of material it will start the conveyor attempting to fill the hopper.

21. Left Conveyor Selector. (Figure 11)

Same operation as above except for left conveyor and its associated switches (22), and left conveyor auto paddle switch.

Since both conveyors are independently controlled, it is possible to run one conveyor in one mode of control while running the other conveyor in a totally different mode if so desired.

23. Hitch Height Switch. (Figure 11)

Push forward to raise the hitch, push rearward to lower the hitch. When the switch is released, the cylinder will hold the hitch at a given height, about which it is free to float up and down on a spring to provide vertical articulation between the chipspreader and truck.

29. Gate Override Pushbutton (Figure 6)

Push down to momentarily fully open the hopper gate to clear a jam. Upon releasing the button, the gate will return to its original set point.

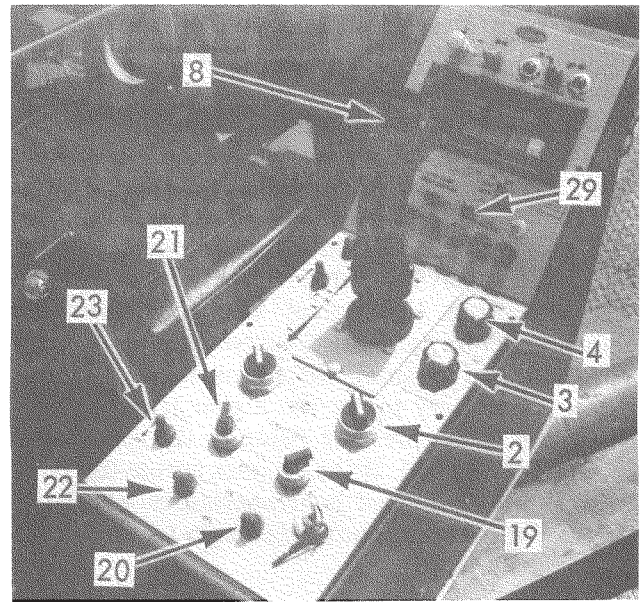

Figure 11. Conveyor Control

- | | |
|-------------------------------------|------------------------------------|
| 2. Mode Selector Manual/Auto | 20. Right Conveyor On/Off |
| 3. Auto Speed Set | 21. Left Conveyor Control Selector |
| 4. Gate Opening Set Point | 22. Left Conveyor On/Off |
| 8. Gate/Spread Roll Switch | 23. Hitch Height Switch |
| 19. Right Conveyor Control Selector | 29. Gate Override Switch |

The following items are located at the front man's station on top of the right conveyor.

30. Left Conveyor Switch

When the driver has selected "front" on the left conveyor selector switch of the main control panel, the left conveyor selector switch at the front man's station will turn the left conveyor "on" or "off".

31. Right Conveyor Switch

When the driver has selected "front" on the right conveyor selector switch of the main control panel, the right conveyor selector switch at the front man's station will turn the right conveyor "on" or "off".

32. Hitch Release Pushbutton

Push the hitch release pushbutton to disengage the supply truck from the chipspreader. (See item 16 of main control panel description).

OPERATION

WARNING

Unsafe operation of equipment may cause injury. Read, understand and follow the manuals when operating or performing maintenance.

IMPORTANT

Do not tow the chipspreader before reading the towing instructions contained in this manual. Improper towing may damage the hydraulic motors.

WARNING

Never put hands in between gate and spread roll or gate and rear of hopper. The gate could move at any time and cause severe injury.

Do not travel with the seal unlatched. Seat movement could occur causing disorientation and possible loss of control.

Shift in and out of "travel" only while stopped or moving at a very slow rate of speed. Shifts between "2nd" and "travel" are very abrupt and could cause personal injury.

Remain clear of all moving parts.

CAUTION

Before operating the chipspreader, make an inspection of the machine to be sure that the machine is in a safe condition to operate.

Always use steps, platforms and handrails provided.

Always have shields, covers and guards in place when operating.

Make certain everyone is clear of machine before starting engine or operation.

Since all functions except power steering and brakes are electrically controlled, turning the ignition key to "off" results in an emergency stop.

Keep loose clothing away from conveyor area when operating conveyors.

Always install locking control box cover and chock wheels when leaving machine unattended as protection against vandalism and accidental movement.

SPEED/GATE OPENING SELECTION

Using chart 1 or 1A, depending on which type of conveyors the machine is equipped with, determine the maximum possible speed which the chipspreader could be operated at and still convey enough material to the front hopper. As an example, using chart number 1 to spread 25 lb./sq. yd. of $\frac{3}{8}$ " chips, enter from the left of the chart at 25 lb./sq. yd. horizontally to the hopper width being used, say 13 ft., read the speed vertically below the intersection to be 415 fpm. Some speed less than this should be used in order to allow some extra capacity for changing trucks.

For example, if 400 fpm was selected as the speed, referring to chart number 2 at 25 lb./sq. yd. and 400 fpm, the required gate opening is $1\frac{7}{16}$ ". This opening should be at least 2 times the size of the stone for reliable feeding therefore the stone should not be larger than $1\frac{1}{16}$ ".

While in chart number 2 note that for $\frac{3}{8}$ " chips the minimum gate opening should be $\frac{3}{4}$ ". The speed to be used with $\frac{3}{4}$ " gate opening is approximately 200 fpm.

The chipspreader can spread 25 lb./sq. yd. of $\frac{3}{8}$ " chips at any of the following combinations of settings:

Gate Opening	Speed
$\frac{3}{4}$ "	200 fpm
1"	275 fpm
$1\frac{1}{8}$ "	300 fpm
$1\frac{1}{4}$ "	350 fpm
$1\frac{7}{16}$ "	400 fpm

For maximum productivity one would want to chip at as high a rate of speed as is practical within the horsepower limitations of the machine, or any outside factors which may arise. (i.e. you are behind the distributor which is running at 300 fpm.)

You now have a selection of gate/speed combinations that will all spread 25 lb./sq. yd. of chips that are $\frac{3}{8}$ ". If you choose a speed greater than 415 fpm, the conveyors may not be able to transfer the material fast enough resulting in having to stop or slow down occasionally to allow them to catch up. If you choose a speed less than 415 fpm, the conveyors can keep up and the chippers should be able to run continuously providing there is a great enough supply of trucks to supply the required amount of chips.

Adjust the gate opener set point to $1\frac{7}{16}$ ", adjust the speed control set point to 400 fpm.

To start spreading at this combination:

1. Turn ignition key to "on."
2. Retard throttle to "low idle."
3. Place control handle in "neutral."
4. Turn ignition key to "start."

5. Check engine oil pressure and coolant temperature after display has made its initial self-check. Allow the engine to reach normal operating temperature before placing any significant load on the engine.

6. Run engine at governed speed. Normal operation of the chippers is at full governed rpm.

7. Select speed range appropriate to the desired working speed. In this case "lo" for maximum torque and best controllability.

8. Select auto speed operation. (Ref. 2, Fig. 11)

9. Depress the override pedal fully.

10. Push speed/direction handle more than 3 degrees forward.

11. Release override pedal slowly and smoothly to the full up position. This must be done slow enough to allow the engine to remain at or near its governed RPM.

12. Depress the gate/spread roll switch (Ref. 8, Fig. 11) fully to the right on reaching the start of spreading.

13. Verify speed as shown on the display after fully releasing the override pedal and adjust if necessary, using the auto speed set point. (Ref. 3, Fig. 11)

14. Stopping—

a) With space available to stop after running off the chipped surface:

1. Center the gate/spread roll switch (Ref. 8, Fig. 11) upon reaching the end of the newly chipped surface.

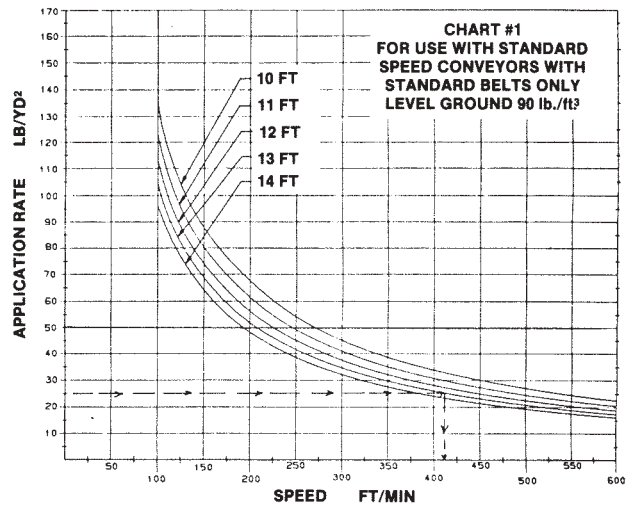

Chart 1. Standard Speed Conveyors with Standard Belts

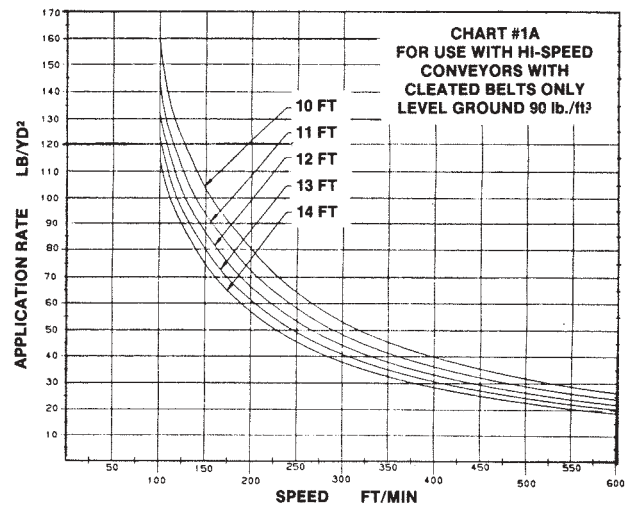
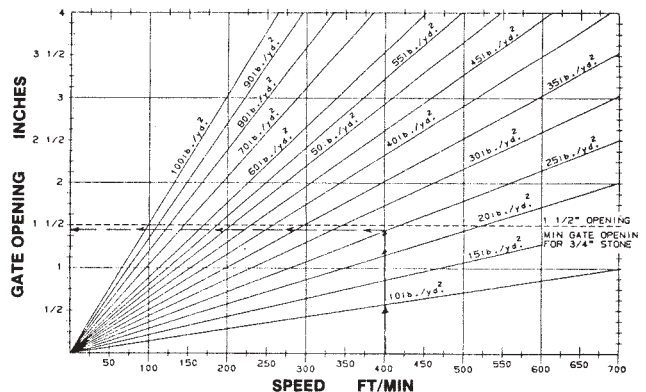

Chart 1A. Hi-Speed Conveyors with Cleated Belts



NOTES:
 1) Minimum gate opening should be approximately 2x stone or greater.
 2) Speed vs gate opening based on aggregate weight of 2400 lb./yd³

Chart 2.

2. Depress the override pedal smoothly to the fully depressed position.
3. Return the control handle to “neutral.”
4. Release the override pedal.

b) Stopping with oil spread in front of chip-spreader:

1. Depress the override pedal smoothly to the fully depressed position.
2. Center the gate/spread roll switch.
3. Return the control handle to “neutral.”
4. Release the override pedal.

15. To back up from this stopped position:

1. Switch auto manual selector to “manual.” (Ref. 2, Fig. 11)
2. Move handle out of neutral to the rear—the more rearward the handle is moved, the faster the machine will back up.
3. To slow and stop the machine smoothly, bring the handle toward and into neutral.

Should a piece of foreign material become lodged in the gates, push the gate override pushbutton (Ref. 29, Fig. 11) to open the appropriate gate above the set point to allow the piece to pass. Releasing the override will return the gates to the previously set position.

⚠ WARNING

Never put hands in between gate and spread roll or gate and rear of hopper to clear obstruction. The gate could move at any time and cause severe injury.

Adjust chipspreader hitch height as necessary to accommodate different individual trucks.

Operate the conveyor belt switches so as to maintain an even distribution of aggregate in the front hopper.

Conveyor flow deflectors should be used to achieve the desired material distribution in the front hopper (Fig. 12).

Conveyor hoods should be used to adjust the distribution to the front hopper, primarily to control the amount of material in the front hopper in the area in front of the conveyor. The amount of material in front of the conveyor will affect when the auto conveyor switch is tripped to shut off the conveyor.

Generally, the larger the stone, the further forward the hood should be positioned. Approximately 1½” gap is a good starting point for ⅜” to ½” chips.

Rear conveyor gates should be adjusted to feed material approximately equal to or slightly more than the rate at which material is being spread. If the machine is equipped with conveyor belt speed controls, these gates should be set to deliver as much material as possible into the conveyor without spillage and then the conveyor speed should be adjusted to deliver the required amount to the front hopper. (Fig. 13)

The operator may wish to disengage the front hopper agitator while spreading clean dry aggregate. This operation is performed by removing the agitator disconnect bolt. This will prevent unnecessary wearing of the agitator. (Fig. 14)

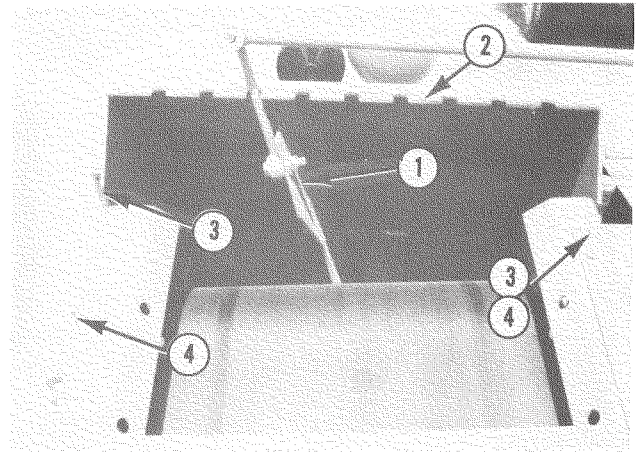

Figure 12. Conveyor Hood and Flow Deflector

- | | |
|----------------------------|-------------------------------|
| 1. Conveyor Flow Deflector | 3. Hood Adjustment |
| 2. Conveyor Hood | 4. Hood Adjustment Set Screws |

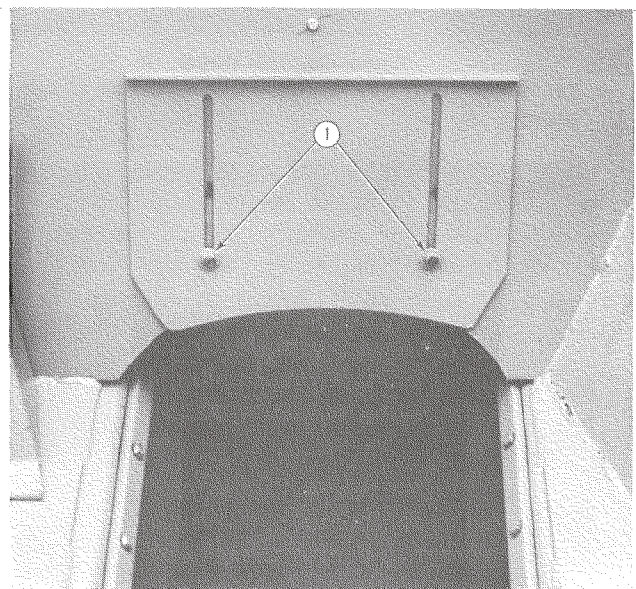

Figure 13. Rear Conveyor Gate

1. Adjustment Bolt

Control Box

The control box may be slid fore and aft approximately 4" by loosening the 4 bolts under the mounting plate and repositioning to the desired position and then retightening the bolts.

Tilt Wheel (Figure 13a)

The steering wheel can be placed in any of its 6 positions by removing the 2 bolts completely, positioning the wheel to the desired position, lining up the new set of holes and inserting the bolts. Be sure to torque the bolts fully to the proper value.

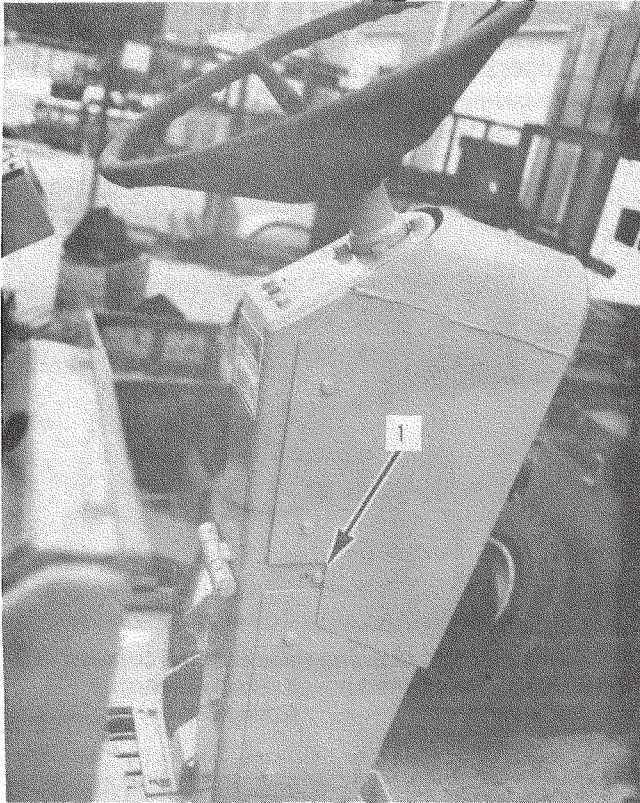

Figure 13a. Tilt Wheel

1. Tilt Wheel Adjustment Bolts (one on each side of steering column).

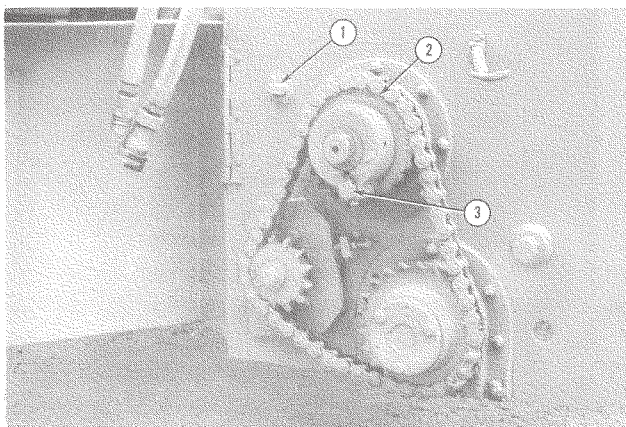

Figure 14. Hopper Chain Drive

1. Drive Bolt Holder
2. Agitator Drive Sprocket
3. Sprocket Drive Bolt

Automatic Conveyor Control (Figure 6)

In the forward position power is supplied to the auto paddle switch mounted below and along the inboard side of the conveyor hood. When this switch is tripped by material moving the paddle, the conveyor will shut "off" and conversely when it is untripped by lack of material it will start the conveyor attempting to fill the hopper. (Fig. 15)

Belt Speed Controls

This feature allows the operator located on the right catwalk to vary the speed of each conveyor independently to provide a uniform distribution of material to the front hopper. Valves for this operation are incorporated in the panel on top of the right conveyor, inboard of each conveyor's solenoid valve. Each valve has a lever with a knob and a locking screw.

With the lever in the full clockwise position, the conveyor will run at its highest speed. Rotating the lever 90 degrees counter-clockwise will completely shut off the conveyor. The lever may be positioned anywhere in between and locked down at the desired speed.

This is particularly useful in doing shoulder work or in operations requiring less than full hopper width. It is also useful in trying to smooth out delivery of material to match the rate being spread. (Fig. 16)

CAUTION

Keep loose clothing away from conveyor area when operating conveyors.

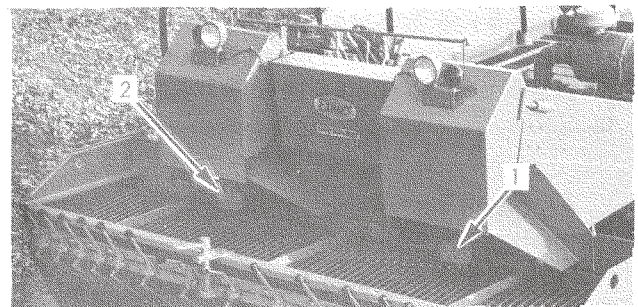

Figure 15. Material Level Paddle

1. Left Paddle
2. Right Paddle

Horn (Fig. 17)

The horn is operated by depressing the trigger on the speed/direction control handle.

Backup Alarm

The electric backup alarm is automatically actuated when the speed/direction control handle (Fig. 17) is pulled to the rear of neutral.

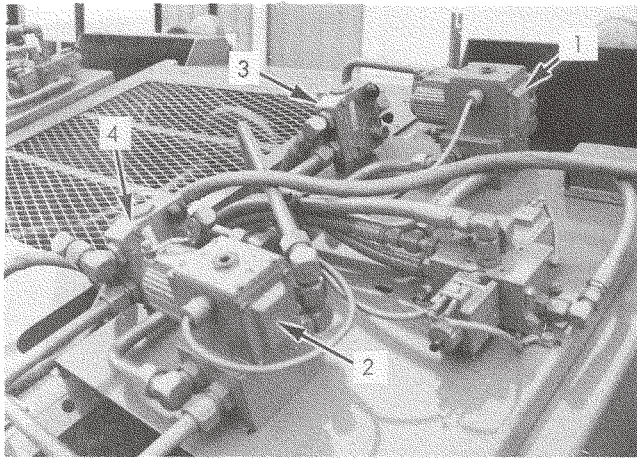

Figure 16. Belt Speed Controls

- | | |
|--------------------------------|----------------------------|
| 1. Rt. Conveyor Solenoid Valve | 3. Rt. Speed Control Valve |
| 2. Lt. Conveyor Solenoid Valve | 4. Lt. Speed Control Valve |

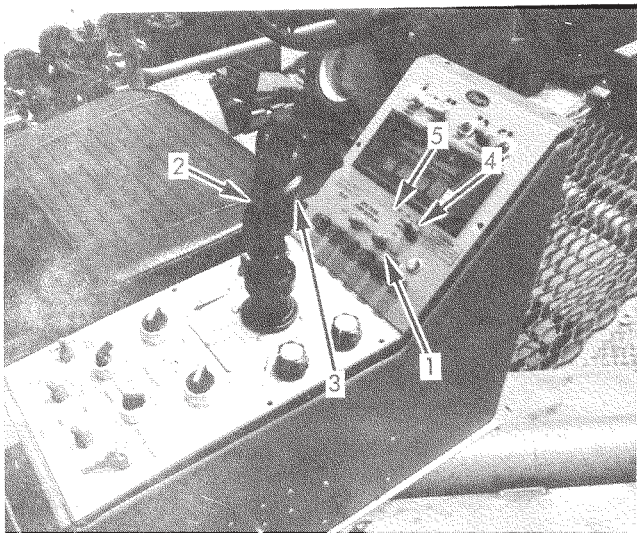

Figure 17. Control Panel

- | | |
|-----------------------------------|--|
| 1. Gate Override | 3. Horn Trigger |
| 2. Speed/Direction Control Handle | 4. Rear Differential Lock Switch |
| | 5. Front/Rear Differential Lock Switch |

Optional Equipment Operation

⚠ WARNING

Unsafe operation of equipment may cause injury. Read, understand and follow the manuals when operating or performing maintenance.

Rear Differential Lock (Positraction)

An electrically controlled flow divider valve is operated by a toggle switch (Figure 17, Ref. 4) on the control panel. When the switch is “on,” the difference in rotational speed between the two rear wheels cannot exceed 10%. This action is exactly like a limited slip deferential in a mechanical rear axle.

This feature is only operable in “lo” and “chip” ranges, it is automatically switched off in the travel range.

Front/Rear Differential Lock (Positraction)

An electrically controlled flow divider valve is operated by a toggle switch (Figure 17, Ref. 5) on the control panel. When the switch is “on,” the difference in rotational speed between the front wheels and the rear wheels cannot exceed 10%. This action is exactly like the limited slip in a full time four wheel drive vehicle.

This feature is only operable in “lo” range and is automatically switched off in “chip” and “travel” ranges.

Electro-hydraulic Powered Seat Assembly

⚠ WARNING

Do not travel with the seat unlatched. Seat movement could occur causing disorientation and possible loss of control.

An electrically controlled hydraulically powered chain drive is operated by a spring centered toggle switch (Fig. 9, Ref. 15). The seat has a manually operated lock pin securing the seat either full left or right travel. The lock pin must be released and locked in the up position before using the electric switch. This is

done by pulling up on the “tee” handle behind the seat raising the pin against the spring and bringing the roll pin thru the slot, and then turning the pin a quarter turn before releasing. The engine must be on and running near its governed RPM in order to have oil flow, and the range selector must be in either “lo” or “chip” to have electric power to the switch. The may then be positioned wherever it is desired for operation. Before shifting to “travel,” the seat must be positioned either full left or right and the lock pin inserted in the hole in the deck. **Warning: Do not travel with the seat unlatched as inadvertant movement could occur causing disorientation and possible loss of control.**

Extra Agitator

When sand or other small aggregate is being spread, an optional second agitator may be placed in the hopper so as to greatly reduce the possibility of bridging. This agitator should be disengaged normally and only used when bridging has been experienced.

Segregation Screen

When the aggregate is not of a uniform size, the optional front hopper segregation screen may be used to place larger chips on the asphalt ahead of smaller chips and fines. This helps prevent the smaller chips and fines from blotting out the larger material (Figure 18).

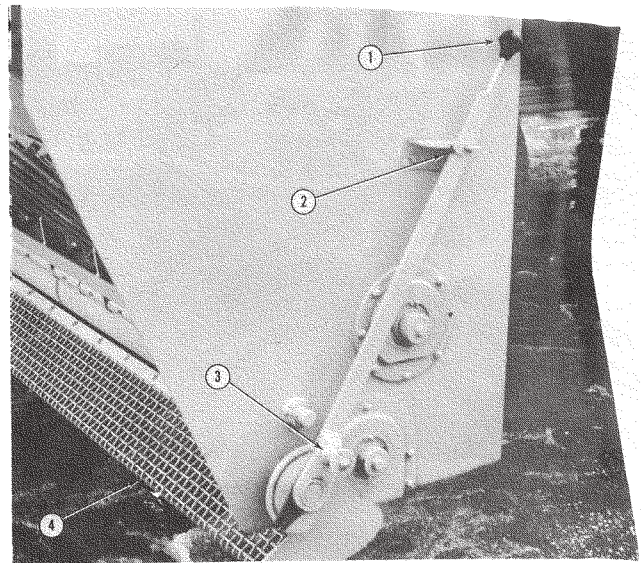

Figure 18. Segregator Screen

- | | |
|-----------|----------------------|
| 1. Handle | 3. Latch |
| 2. Lock | 4. Segregator Screen |

OPERATING RANGES

For Standard
2WD
ChipSpreader
with
152 HP Cummins 6BT Engine
142 HP CAT 3208 Engine

ChipSpreader can be operated anywhere to the lower left of the appropriate gross weight curve.

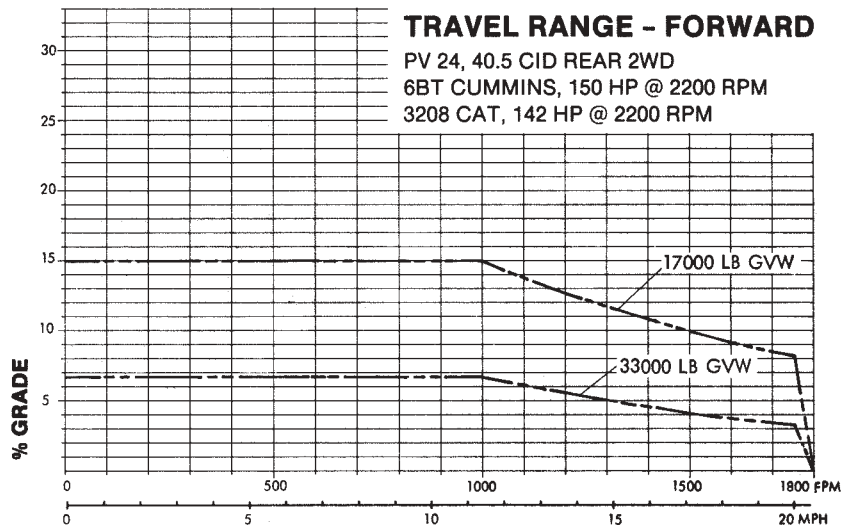
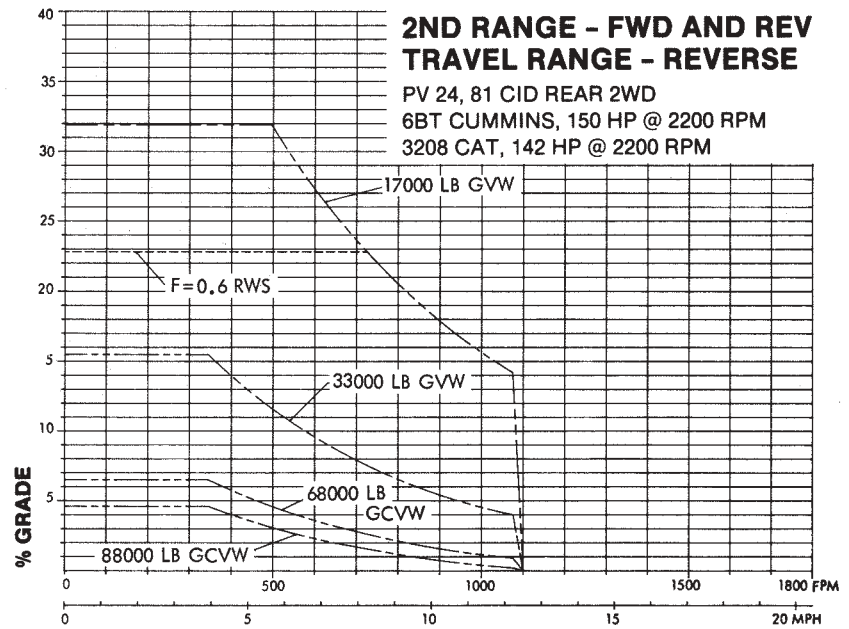
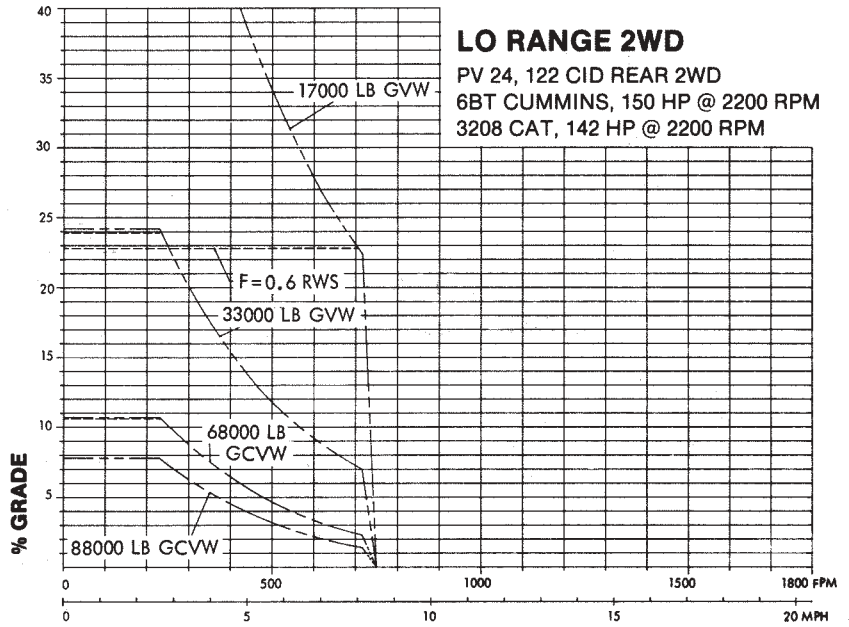

OPERATING RANGES

For 4WD
ChipSpreader
 with
190 HP Cummins 6BTA Engine
165 HP CAT 3208 Engine

ChipSpreader can be operated anywhere to the lower left of the appropriate gross weight curve.

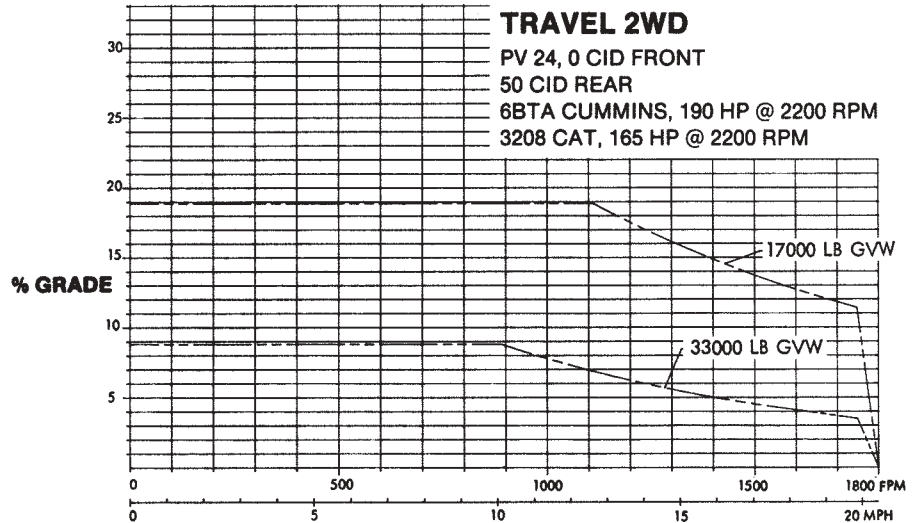
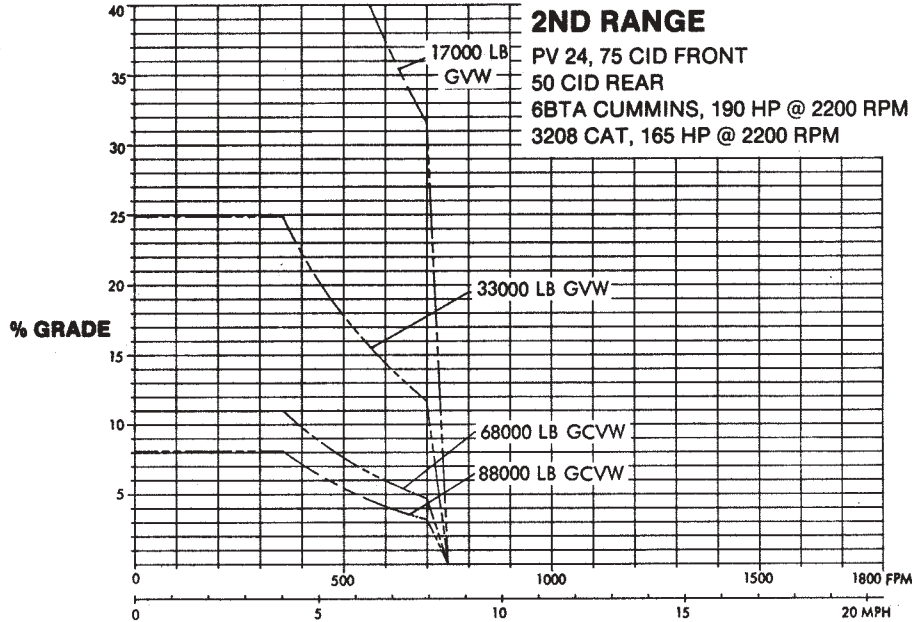
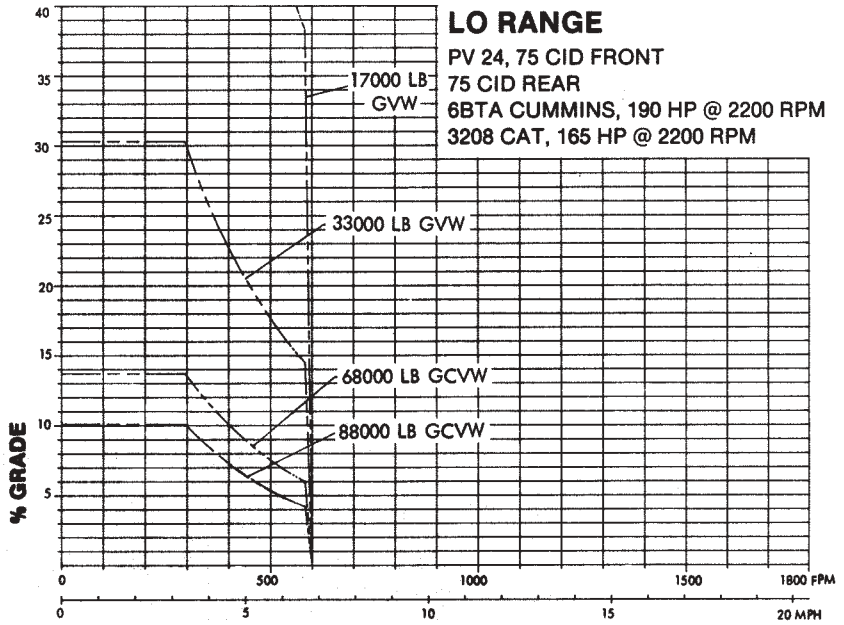

OPERATING RANGES

**For 4WD ChipSpreader
with
210 HP Cummins 6CT Engine
219 HP CAT 3208T Engine**

ChipSpreader can be operated anywhere to the lower left of the appropriate gross weight curve.

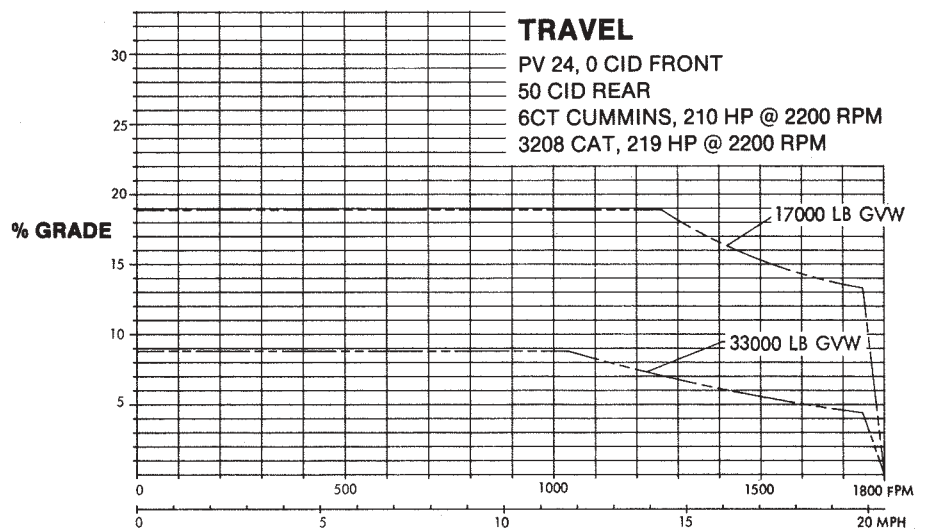
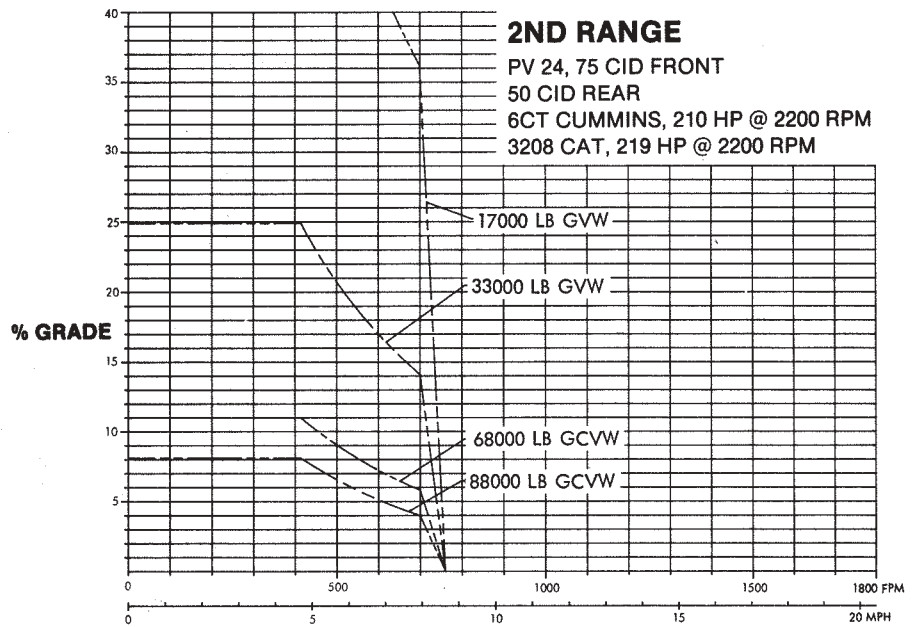
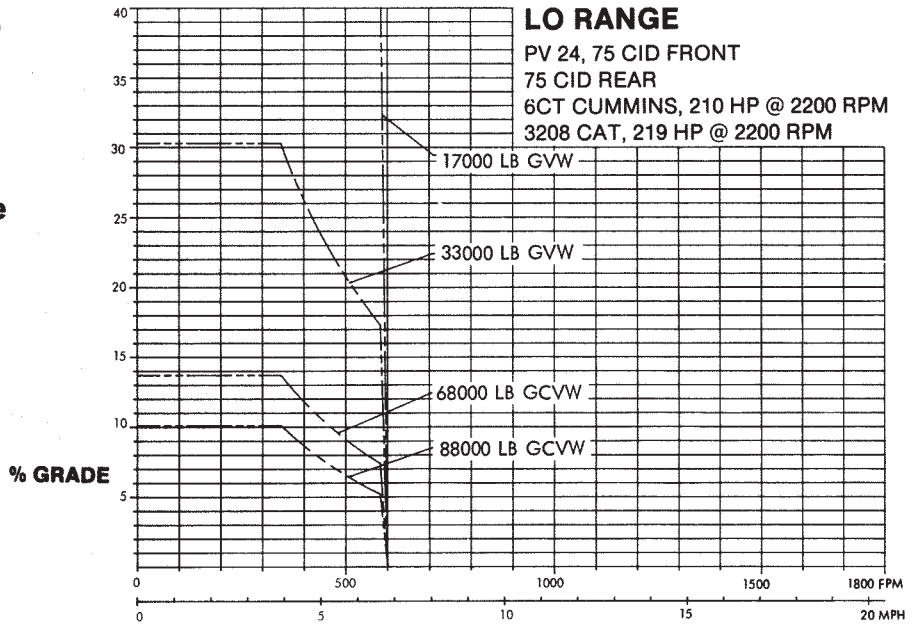

OPERATING RANGES

For 4WD ChipSpreader
with
234 HP Cummins 6CTA Engine

ChipSpreader can be
operated anywhere to the
lower left of the appropriate
gross weight curve

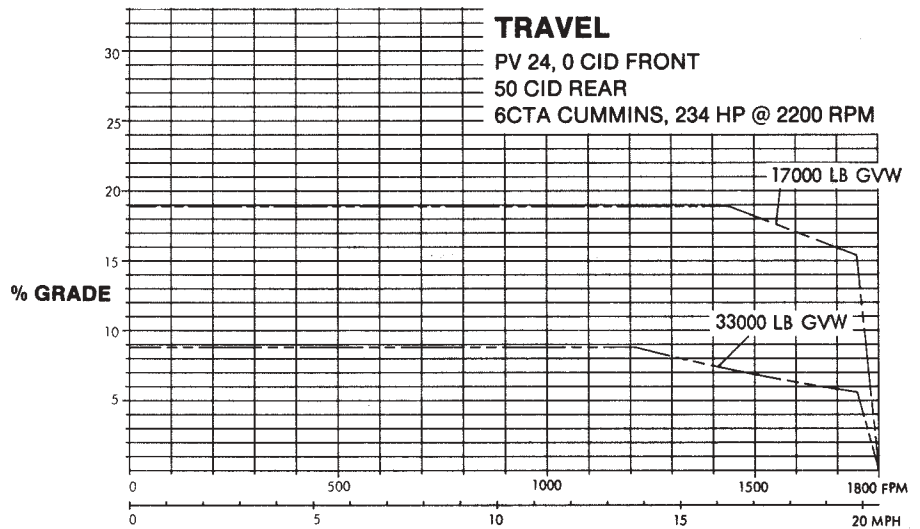
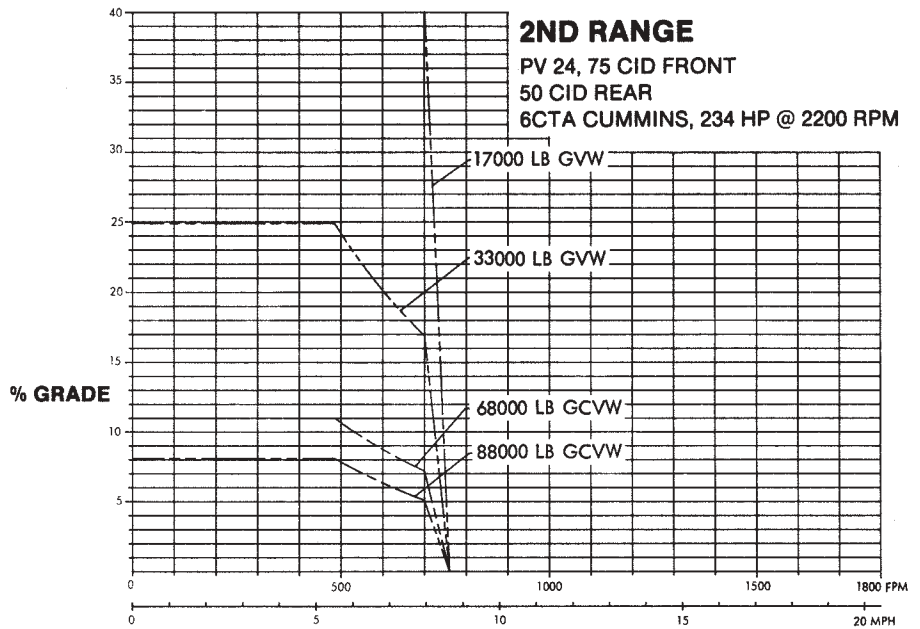
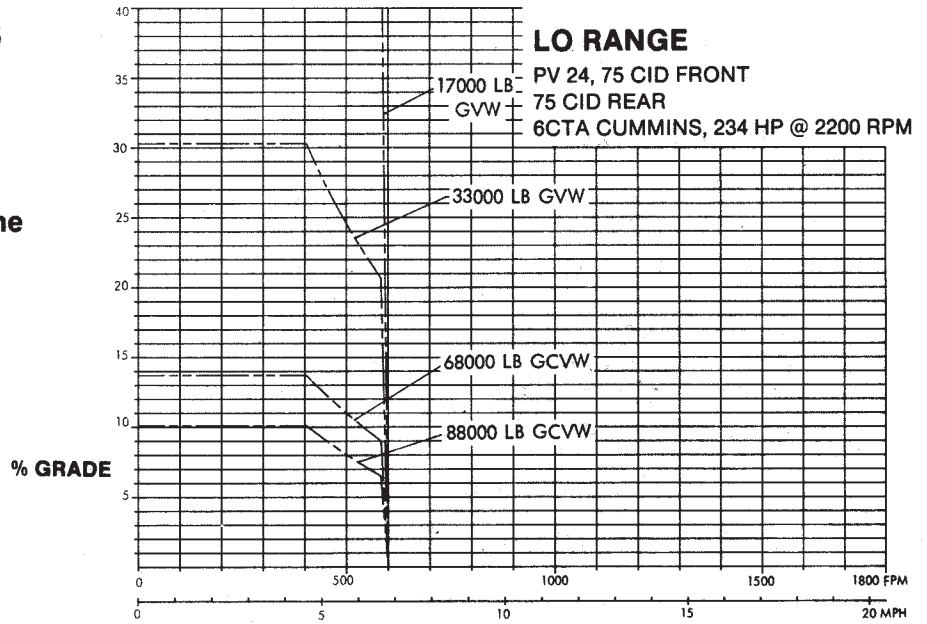

MAINTENANCE ADJUSTMENTS

⚠ WARNING

Never put hands in between gate and spread roll or gate and rear of hopper. The gate could move at any time and cause severe injury.

The fuel tank is part of the crosswalk. Do not drill or weld in this area.

When two people are required to perform adjustments or maintenance operations or two people are simultaneously performing different operations, the work must be coordinated between the two people to avoid possible injuries.

⚠ CAUTION

Always use steps, platforms and handrails provided.

Make certain everyone is clear of machine before starting engine or operation.

Keep loose clothing away from conveyor area when operating conveyors.

To avoid potential damage to electrical components disconnect batteries before welding.

Rear Hopper Flow Gate Adjustment (Fig. 13)

Turn spread roll and conveyors “off.”

1. Loosen flow gate retaining bolts.
2. Raise gate to increase conveyor flow to front hopper.
3. Lower gate to decrease conveyor flow to the front hopper.
4. Retighten flow gate retaining bolts.

Hopper Spread Roll Wear Plate Adjustment

Turn spread roll and conveyors “off.”

1. Loosen all spread roll wear plate hold down bolts (Figure 19) and adjust the wear plate until a nominal $\frac{1}{16}$ ” clearance exists between the wear plate and the spread roll for the entire hopper width.
2. Retighten all the hold down bolts.
3. When one side of a plate has worn away it is possible to turn the plate over and use the opposite side.

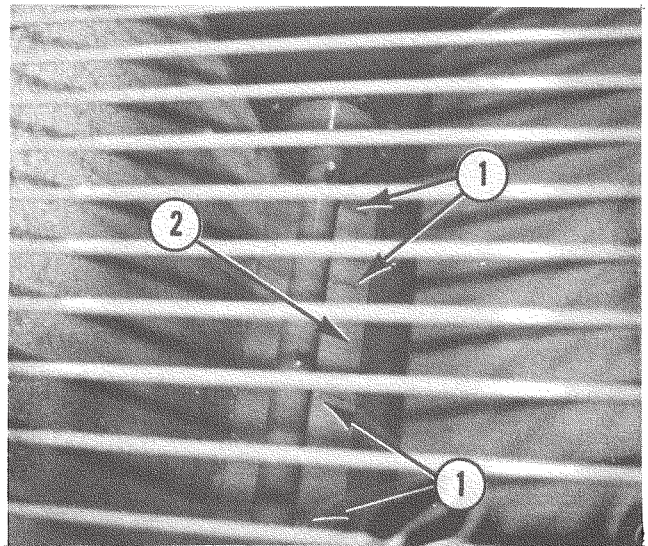

Figure 19. Spread Roll Wear Plate
(Viewed from top of hopper, looking down)

1. Hold Down Bolts 2. Spread Roll Wear Plate

Hopper Gate Wear Plate Adjustment (Fig. 20/20a)

Turn spread roll and conveyors “off.”

1. Loosen wear plate hold down bolts and extend the plate $\frac{1}{32}$ ” past the gate edge along the entire gate width.
2. Tighten hold down bolts.
3. As plate wear occurs, additional adjustment will be necessary.
4. When one side of a plate has been worn away it is possible to turn the plate over and use the opposite side.

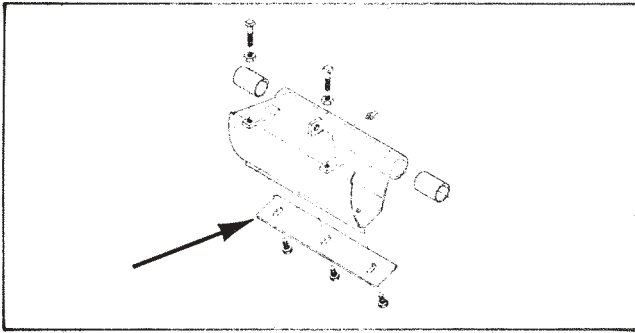

Figure 20. Gate Wear Plate

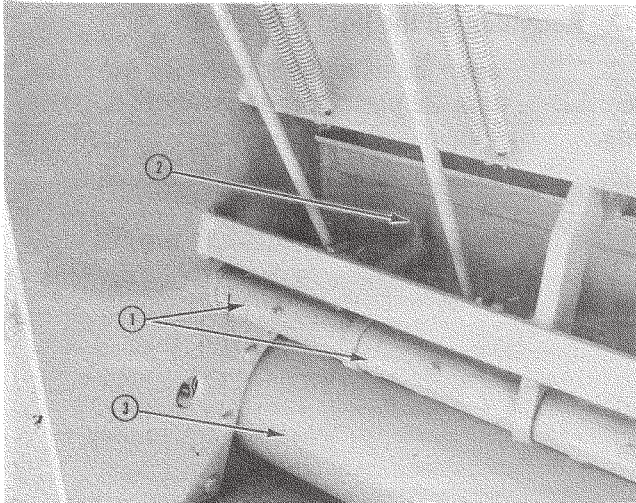

Figure 20a. Hopper Gates

1. Gates 2. Adjustment Bolts 3. Spread Roll

Hopper Gate Linkage Adjustment

1. Loosen gate adjustment screw jam nuts.
2. With hopper removed from the spreader or the reach rod disconnected, each gate adjustment screw should be set so as to maintain $\frac{1}{16}$ " clearance between the gate wear plate and spread roll. (Ref. 2, Fig. 20/20A)
3. Tighten gate adjustment screw jam nuts.
4. Adjust the gate linkage length by turning the control lever ball joint connector "in" or "out" until the control lever just touches the actuator bar stop while maintaining the $\frac{1}{16}$ " gate clearance. (Ref. 7, Fig. 21)

Conveyor Belt Adjustment

WARNING

Conveyor must be running during this procedure. To avoid personal injury, be sure to remain clear of moving belt.

1. If the conveyor belt tends to move towards one side of the conveyor, tighten tail pulley adjustment on that side until the belt is running in the center.

2. Should it be impossible to obtain centered belt operation by adjusting the tail pulley (Fig. 22) it will then be necessary to adjust the head pulley as outlined below. (Fig. 23)

For the right hand conveyor:

- a) Loosen the four bolts holding the left hand side head pulley bearing.
- b) Loosen adjusting bolt jam nuts.
- c) Start conveyor at this time.

WARNING

Remain clear of all moving parts.

d) If belt runs to the right hand side of the conveyor, loosen the adjusting screws until the belt is centered on the head pulley.

e) If belt runs to the left hand side of the conveyor, tighten the adjusting screws until the belt is centered on the head pulley.

f) Retighten adjusting screw jam nuts.

g) Stop the conveyor belt.

h) Tighten head pulley bearing bolts.

For left hand conveyor:

a) Loosen the four bolts holding the right hand side head pulley bearing.

b) Loosen the adjusting bolt jam nuts.

c) Start conveyor at this time.

WARNING

Remain clear of all moving parts.

d) If belt runs to the right side of the conveyor, tighten the adjusting screws until the belt is centered on the head pulley.

e) If belt runs to the left side of the conveyor, loosen the adjusting screws until the belt is centered on the head pulley.

f) Retighten adjusting screw jam nuts.

g) Stop the conveyor belt.

h) Tighten head pulley bearing bolts.

NOTE: Only a small amount of head pulley adjustment should be necessary to center conveyor belts.

3. Conveyor belts should be sufficiently tight to prevent head pulley slippage when the belts are loaded and operating at full governed speed. It should be noted, however, that excessive belt tightness will result in shortened belt and pulley bearing life. It may be necessary to tighten the belts several times during the first few weeks of operation until most of the initial belt stretch has been removed. When doing so it is necessary to tighten each side equally to keep the belt running centered.

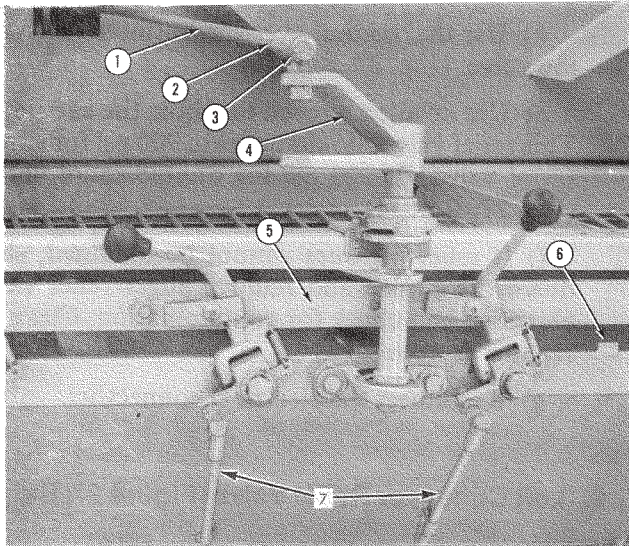

Figure 21. Hopper

- | | |
|--------------------------|---|
| 1. Reach Rod | 5. Gate Actuator Bar |
| 2. Jam Nut | 6. Bar Spacer Block (Insert Shim Here for Adjustment) |
| 3. Ball Joint | 7. Ball Joint Connector and Locknut |
| 4. Control Arm and Shaft | |



Figure 22. Conveyor Tail Pulley

1. Conveyor Belt Tail Pulley Adjustment Bolt (4 Places)

⚠ WARNING

Never put hands in between gate and spread roll or gate and rear of hopper. The gate could move at any time and cause severe injury.

⚠ WARNING

The fuel tank is part of the crosswalk. Do not drill! or weld in this area.

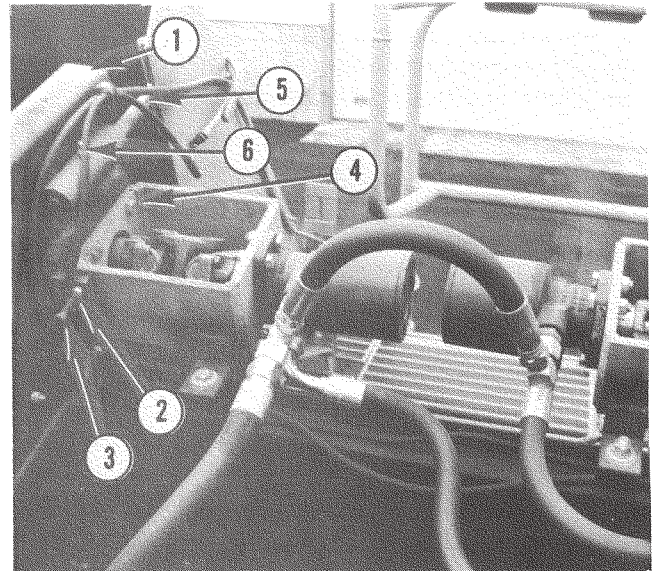

Figure 23. Conveyor Head Pulley Adjustment

- | | |
|--------------------|-------------------------------|
| 1. Left Conveyor | 4. Bearing Bolts |
| 2. Jam Nut | 5. Hood Adjustment |
| 3. Adjusting Screw | 6. Hood Adjustment Set Screws |

Relief and Reducing Valve Pressure Adjustments

Before making any relief valve adjustments check to insure that there is sufficient oil in the hydraulic reservoirs and that all the filter elements are free of contamination. All pressures are to be set with the oil temperature at at least 110 degrees.

⚠ WARNING

When two people are required to perform adjustments or maintenance operations or two people are simultaneously performing different operations, the work must be coordinated between the two people to avoid possible injuries.

1. Hopper Spread Roll Relief Valve (Figure 24)

a) With engine off, remove cap (1) and install a 3000 psi gage with necessary adapters to hook to 3/4" JIC (12MJ) male fitting (Ref. 1, Fig. 25).

b) Disconnect the hopper hoses and leave them uncoupled.

c) Run the engine at governed RPM (approximately 2300 RPM).

d) Use the manual override to actuate the valve. (Fig. 24, Ref. 1)

e) Loosen locknut and using allen wrench, set the pressure to 1500 psi and retighten the locknut.

f) If relief pressure cannot be obtained, shut down the engine and remove the hopper relief valve cartridge and check for contamination. Clean or replace as necessary.

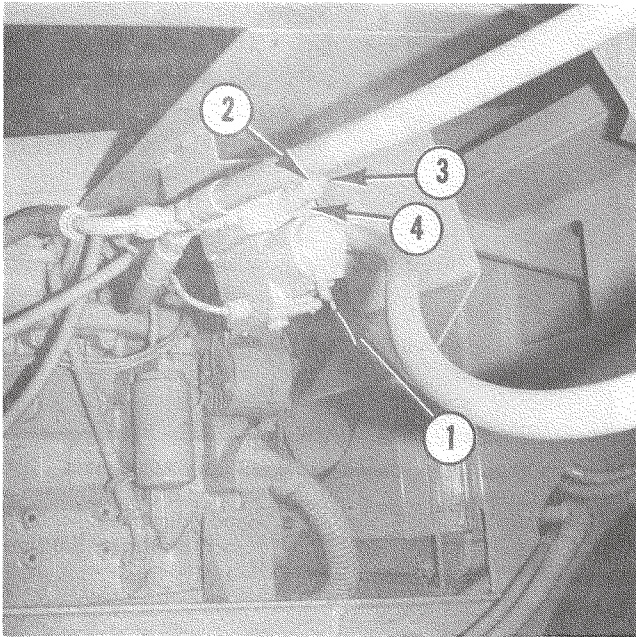

Figure 24. Spread Roll Relief Valve

- | | |
|--------------------|-----------------------------|
| 1. Manual Override | 3. Adjustment Screw |
| 2. Locknut | 4. Spread Roll Relief Valve |

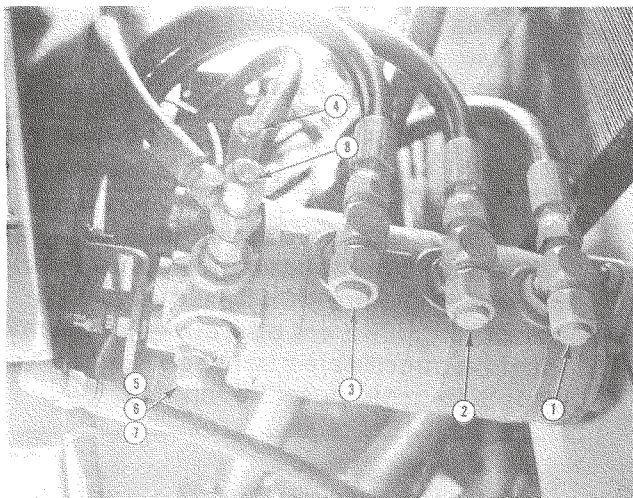

Figure 25. Front Hydraulic Pump

- | | |
|---------------------------|--------------------------------|
| 1. Cap (1) Spread Roll | 5. Cap (5) Secondary Power |
| 2. Cap (2) Lt. Conveyor | 6. Locknut (6) |
| 3. Cap (3) Rt. Conveyor | 7. Power Steering Relief Valve |
| 4. Cap (4) Power Steering | 8. Cap (8) Power Gate/Seat |

2. Power Gate Relief Valve (Figure 27)

a) With the engine off, remove cap (8) (Fig. 25) and install a 3000 psi gage with necessary adapters to hook to a 1/2" JIC (08 MJ) male fitting. Disconnect the two cylinder hoses and install 1/2" JIC caps 9403374 on the male fittings on the top of the

valve (if it is a single spool valve—Gate opener only). Or, if it is a double spool valve (gate opener inboard and powered seat outboard) disconnect the hoses from the inboard spool and install the caps on the male fittings.

b) Disconnect the orange wire from one solenoid and the brown wire from the other solenoid (single spool valve or the inboard spool of double valve).

c) Start the engine and run at 2300 RPM (governed speed).

d) Use the manual override button to activate the valve. (Fig. 27, Ref. 10)

e) Use an allen wrench to adjust the cartridge. This relief valve should be set to 900 psi for single spool valve, or 900 psi for double spool valve. (Fig. 27, Ref. 11)

f) If relief pressure cannot be obtained, shut down the engine and remove auger relief valve cartridge and check for contamination. Clean or replace as necessary.

g) Reconnect the electrical connectors.

9. Left Conveyor Relief Valve (Figure 27, Ref. 4)

a) With engine off remove cap (2) (Fig. 25, Ref. 2) and install a 3000 psi gage with necessary adapters to hook to a 3/4 JIC (12 MJ) male fitting.

b) Hold (lock) the left conveyor head pulley with a pipe wrench or other suitable tool. (Fig. 26)

Use caution when doing this operation. Be sure wrench is securely positioned on U-joint and rotated by hand against supporting steel so it cannot rotate further.

c) The engine should be run at governed speed (approximately 2300 RPM).

d) Use the manual override to actuate the valve (Fig. 27, Ref. 2).

e) This relief should be set at 2100 psi.

f) If relief pressure cannot be obtained, shut down the engine and remove left conveyor relief valve cartridge and check for contamination or damaged cartridge pieces. Clean and replace as necessary.

4.) Right Conveyor Relief Valve (Figure 27)

a) With engine off, remove cap (Ref. 3, Figure 25) and proceed the same as the left conveyor.

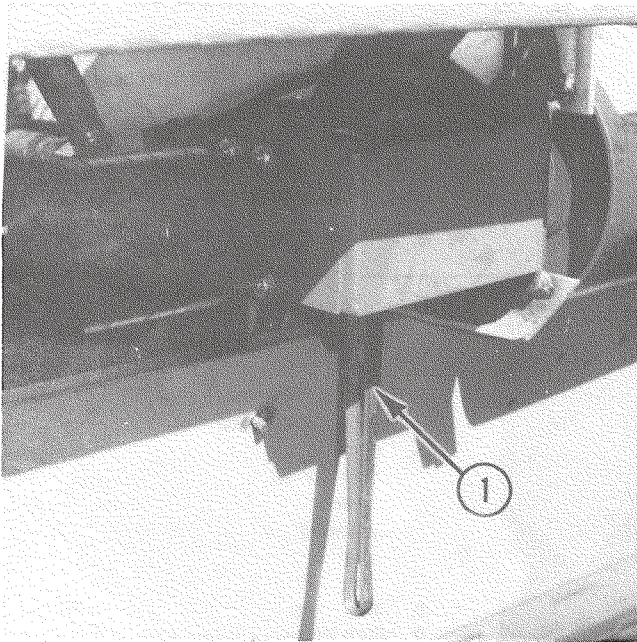

Figure 26. Lock Left Conveyor Head Pulley

1. Large Pipe Wrench Secure Against Unit Frame

! WARNING

Use caution when doing this operation. Be sure wrench is securely positioned on U-joint and rotated by hand against supporting steel so it cannot rotate further.

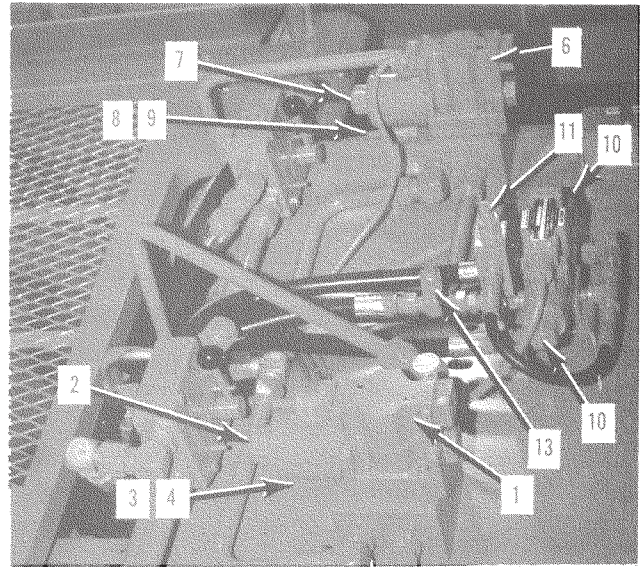

Figure 27a. Conveyor Control without Powered Seat

- | | |
|--------------------------------|----------------------------|
| 1. Lt. Conveyor Valve | 8. Locknut |
| 2. Manual Override - Lt. Conv. | 9. Relief Set Location |
| 3. Locknut | 10. Manual Override Button |
| 4. Relief Set Location | 11. Cartridge Adjust Point |
| 6. Rt. Conveyor Valve | 13. Gauge Port - Gates |
| 7. Manual Override - Rt. Conv. | |

5.) Power Steering Relief Valve (At Hydraulic Control Assembly) (Fig. 28a or 28b, Ref. 5)

a) With engine "off," remove cap (4) on pump (Fig. 25) and install a 3000 psi gage with necessary adapters to hook up to a 1/2" JIC (08 MJ) male fitting.

b) The engine must be run at or above 950 RPM.

c) Turn the front wheels full left or right until the wheels are against the stops (2WD) or the cylinder is fully stroked (4WD).

d) While holding the wheels full left or right set the relief valve pressure to 1950 psi.

e) If the relief pressure cannot be reached, the secondary relief valve within the pump may be set below 1950 psi. To verify and set this relief valve (Fig. 25) remove cap (5), loosen locknut (6) and adjust relief valve (7) to 2000 psi (Fig. 25) while holding the wheels full left or right.

f) Return to the relief valve at the hydraulic control assembly and repeat steps 4b, c and d.

g) If relief pressure cannot be obtained at either cartridge, shut down the engine, remove appropriate cartridge and check for contamination or damaged cartridge pieces. Clean or replace as necessary.

6.) Hydraulic Control Pressure Relief (Figure 28a or 28b, Ref. 6)

a) With the engine off, remove pipe plug (5) and insert a 3000 psi gage.

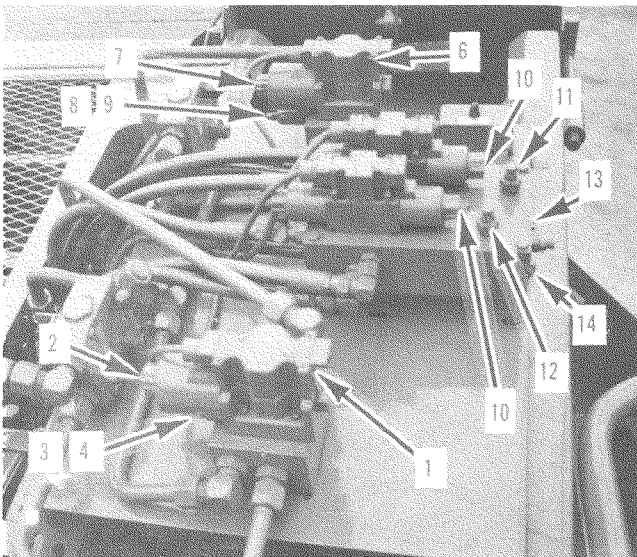

Figure 27. Conveyor Control with Powered Seat

- | | |
|--------------------------------|------------------------------------|
| 1. Lt. Conveyor Valve | 10. Manual Override Button |
| 2. Manual Override - Lt. Conv. | 11. Cartridge Adjust Point - Gates |
| 3. Locknut | 12. Cartridge Adjust Point - Seat |
| 4. Relief Set Location | 13. Gauge Port - Gates |
| 6. Rt. Conveyor Valve | 14. Gauge Port - Seat |
| 7. Manual Override - Rt. Conv. | |
| 8. Locknut | |
| 9. Relief Set Location | |

- b) Run the engine at or above 950 RPM.
- c) Loosen locknut and adjust pressure to approximately 600 psi (Fig. 28a/28b, Ref. 6).
- d) Shut engine down, remove 3000 psi gage, and install 1000 psi gage.
- e) Restart engine and run at or above 950 RPM.

f) Adjust relief valve to 400 psi and retighten locknut.

g) If relief pressure cannot be obtained, shut down the engine and remove the control pressure relief valve cartridge and check for contamination or damaged cartridge pieces. Clean or replace as necessary.

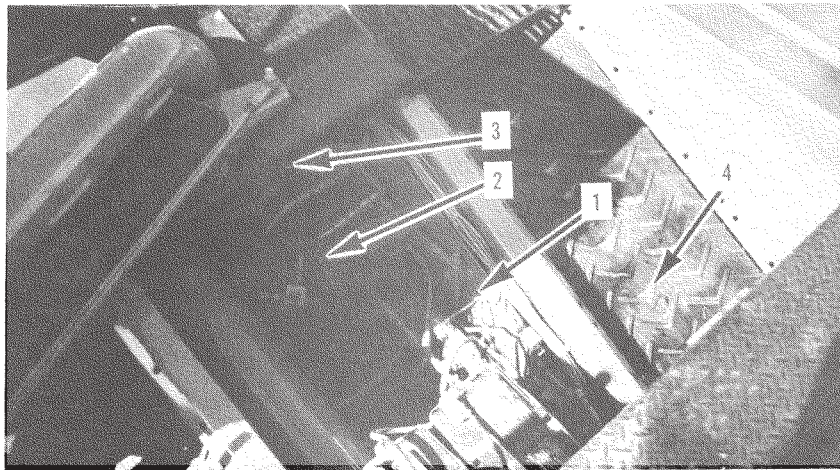
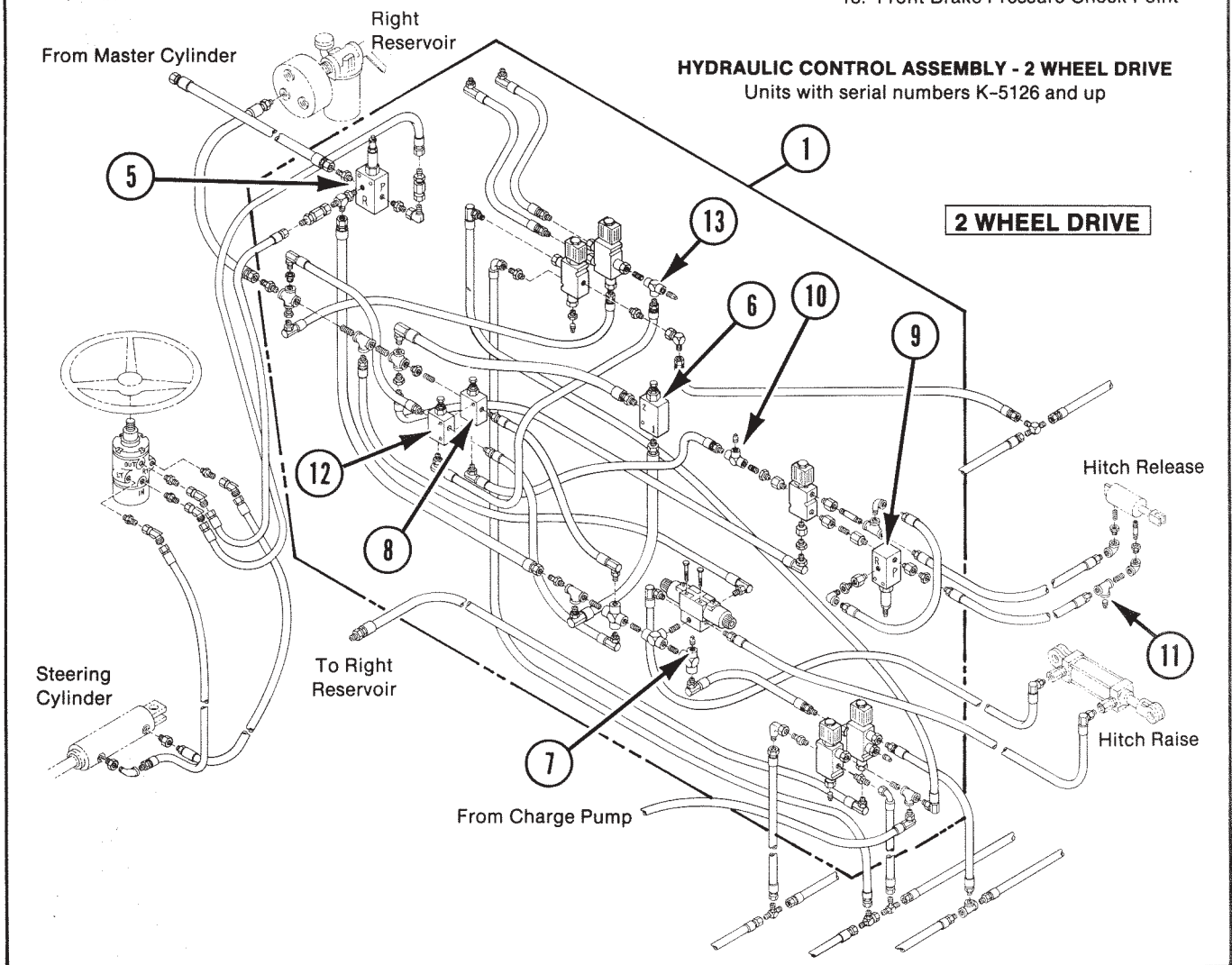

Figure 28A.
Hydraulic Control Assembly,
2 Wheel Drive

- 1. Hydraulic Control Assembly
- 2. Hydrostatic Pump
- 3. Engine
- 4. Right Conveyor
- 5. Power Steering Relief Valve
- 6. Hydraulic Control Pressure Relief Valve
- 7. Control Pressure Check Port
- 8. Hitch Pressure Reducing Valve
- 9. Hitch Pressure Relief Valve
- 10. Hitch Pressure Check Port
- 11. Hitch Pressure Relief Check Port
- 12. Front Brake Pressure Reducing Valve
- 13. Front Brake Pressure Check Point



7.) Hitch Release Pressure Reducing Valve
(Figure 28a or 28b, Ref. 8)
and Hitch Relief Valve
(Figure 28a or 28b, Ref. 9)

- a) With the engine off, remove pipe plug (Ref. 10) and insert a 1000 psi gage.
- b) Run the engine at or above 950 RPM.

- c) Loosen locknut and set reduced pressure to 250 psi (Fig. 28a/28b, Ref. 2).
- d) Shut engine down, remove pipe plug (Ref. 10) and insert a 600 psi gage.
- e) Run the engine at or above 950 RPM.
- f) Loosen locknut and set relief pressure to 130 psi (Fig. 28a/28b, Ref. 9); retighten locknut.

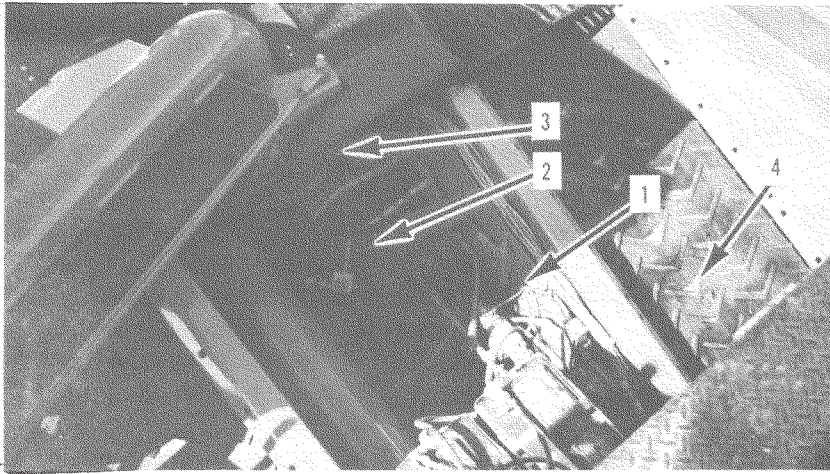
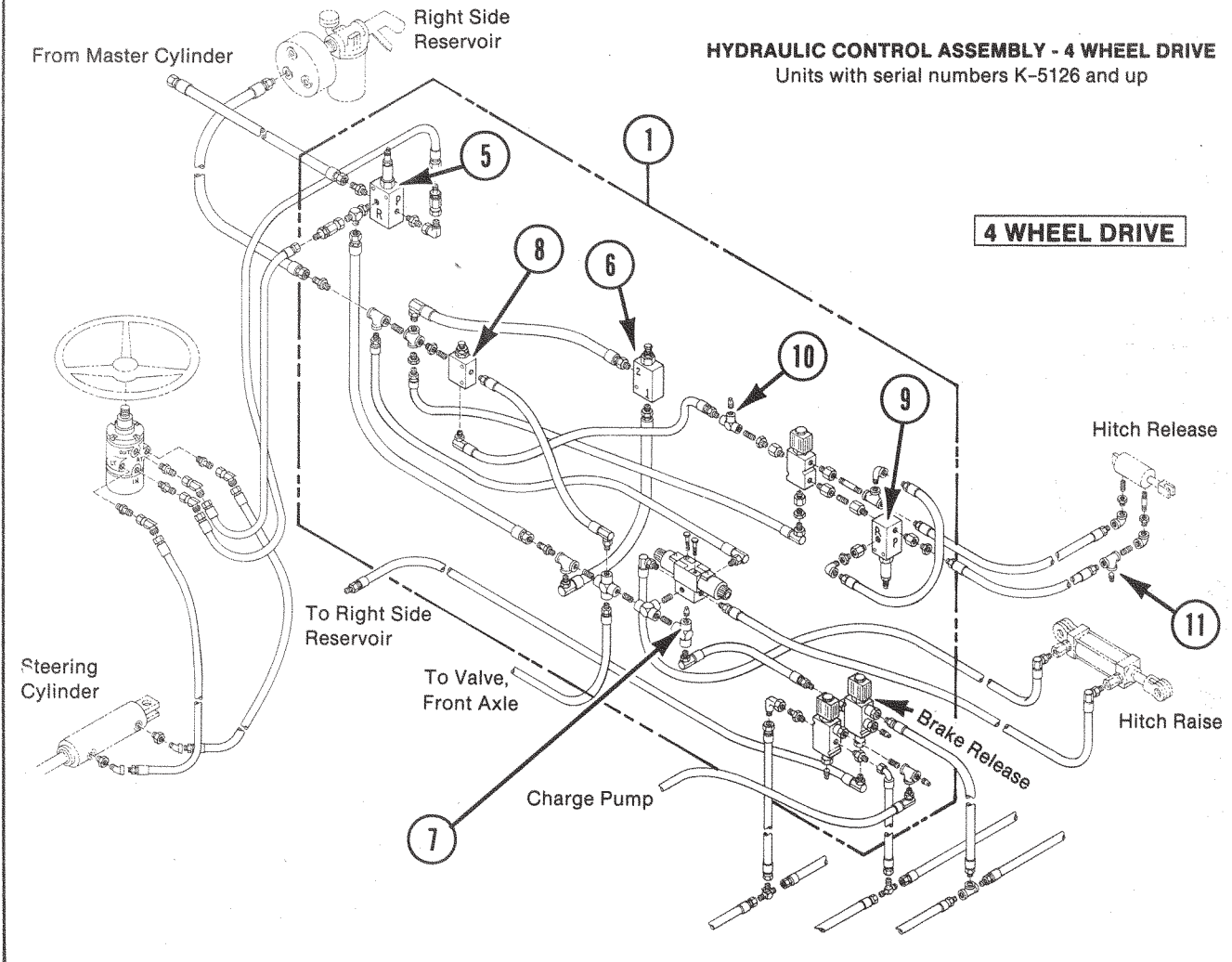

Figure 28B.
Hydraulic Control Assembly,
4 Wheel Drive

- 1. Hydraulic Control Assembly
- 2. Hydrostatic Pump
- 3. Engine
- 4. Right Conveyor
- 5. Power Steering Relief Valve
- 6. Hydraulic Control Pressure Relief Valve
- 7. Control Pressure Check Port
- 8. Hitch Pressure Reducing Valve
- 9. Hitch Pressure Relief Valve
- 10. Hitch Pressure Check Port
- 11. Hitch Pressure Relief Check Port



g) Return to the pressure reducing valve, loosen locknut and reset reduced pressure from 250 psi down to 100 psi and retighten locknut.

h) If reduced and/or relief pressures cannot be set, shut down engine and recheck hydraulic control pressure to be sure it is at 400 psi. If it is, shut down engine and remove the reducing valve or relief valve cartridge and check for contamination or damaged cartridge pieces. Clean or replace as necessary.

8. Front Brake Pressure Reducing Valve (Figure 28a, Ref. 12) 2WD Only

a) With the engine off, remove pipe plug (Ref. 13) and insert a 1000 psi gage.

b) Run the engine at or above 950 RPM.

c) Loosen locknut and set reduced pressure to 250 psi (Fig. 28a, Ref. 12).

Hydrostatic System Startup

WARNING

Be certain that machine is securely supported on stands. Wheels will be rotating under power.

After any work has been done on the hydrostatic ground drive system which involved opening up the circuit in any way, the following startup procedure should be used.

1. Jack the machine up and securely support on stands with all four wheels off the ground. **Warning: Be certain that machine is securely supported on stands. Wheels will be rotating under power and if they contact the ground or debris becomes lodged between the wheels and ground, the chippers could drive off the stands.**

2. Disconnect the fuel solenoid wire at the engine, so that the engine can only be cranked and cannot be started. (Fig. 29)

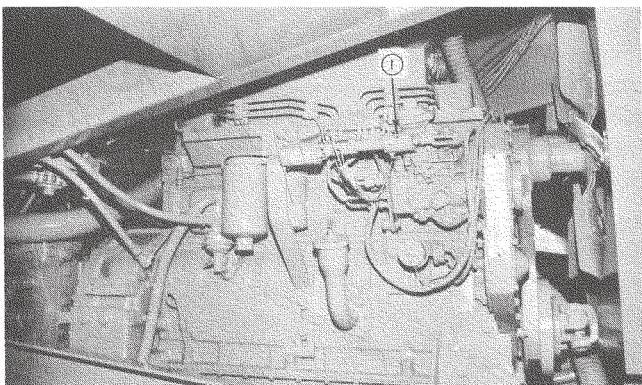

3. Disconnect pump stroker at the pump.

4. Insert a 600 psi gage in the charge pressure gage port on the left side of the pump.

5. Remove suction filter elements; fill with hydraulic oil and reinstall. (Fig. 30)

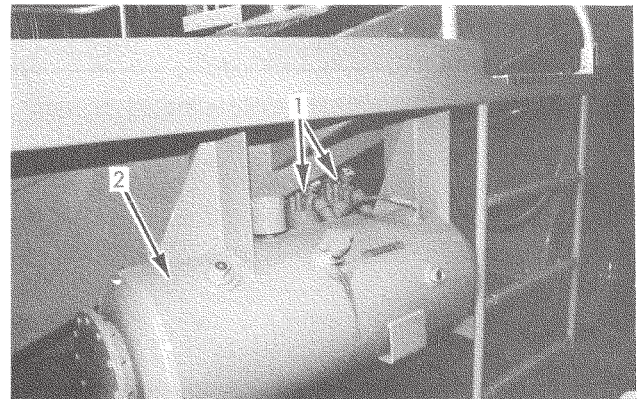

Figure 30. Suction Filters

1. Suction Filters

2. Hydraulic Reservoir

6. Remove cap on tee on high side drain hose on pump and fill pump case with hydraulic oil. If a fill tank is used to supply oil, it should be positioned higher than the hydraulic tanks. If this is done, the entire system can be filled from this one location.

7. Turn ignition key "on" and retard throttle to idle. Turn key to "start" and crank engine with starter until seeing at least 40 to 60 psi on the charge pressure gage. **Do not crank for more than 30 seconds.** Wait at least 2 minutes before cranking again. If no pressure reading can be obtained after 2 or 3 attempts, the starter may not be cranking the engine fast enough to develop charge pressure.

8. Hook up fuel solenoid valve.

9. Turn ignition key to "start" and release, letting engine run at idle. Observe the charge pressure for a reading within 30 seconds. Once a reading is seen, allow the engine to idle for about 10 minutes. During filling of all lines and components, the charge pressure can surge between 50 and 500 psi. As the system fills, surging will decrease and the charge pressure should settle down to a steady reading between 150 and 300 psi.

10. The pump stroker (Fig. 31) null or zero should now be centered using the following procedure. This step only needs to be done if the pump or stroker has been changed.

a) Loosen the null adjust locknut.

b) Using a $\frac{3}{16}$ hex key, slowly turn the null adjust screw clockwise until the charge pressure begins to decrease (indicating the pump is going on stroke in one direction). Slowly turn the null adjustor counter-clockwise while counting the

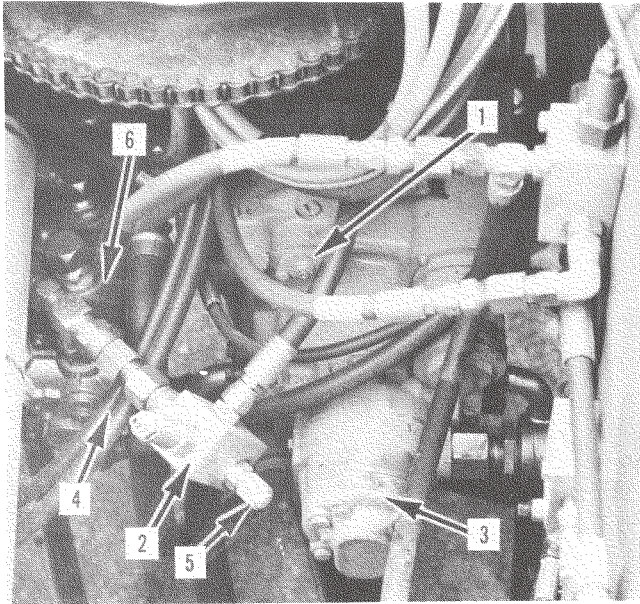

Figure 31. Rear Pump

- | | |
|--------------------------|--|
| 1. Null Adjuster | 4. Built in Relief Valve (hidden by hoses in this view, located on right side of pump near bottom) |
| 2. External Relief Valve | 5. Cap |
| 3. Hydrostatic Pump | 6. Rear Pump |

number of turns until the charge pressure begins to decrease (indicating the pump is going on stroke in the opposite direction).

c) Turn the null adjuster clockwise half the amount observed in step b. This should be the center of neutral.

d) Hold the null adjuster with the hex key and tighten the locknut to a torque of 14-18 lbs.

11. Check fluid levels in reservoirs and add if necessary.

12. Run the engine at 1000 to 1200 RPM. Charge pressure should be 200 to 300 psi and steady. Case pressure should be 15 to 30 psi. Return engine to idle and shut it down.

13. Place range selector in low; place auto/manual selector in manual and reconnect the pump stroker.

14. Check for debris under any wheel.

15. Start engine and run at 1000 to 1200 RPM. Observe charge and case pressure. Charge pressure should be 190 to 230 psi above case pressure. Move the handle slowly to the full forward position and then full reverse. Repeat this cycle for about 5 minutes. When the pump is on stroke in either direction, the charge pressure should be 160 to 200 above the case pressure. In all cases, the difference between charge pressure and case pressure should be greater when in neutral than when the pump is on stroke in forward or reverse.

16. Slowly, in steps, run the engine up to full RPM while observing the charge pressure. Repeat step 16 with the engine at full RPM. At any sign of unsteadiness in the charge pressure, shut the engine down immediately and check for problems in the suction part of the system, such as clogged filter, leaks or blockage.

17. Shut down engine, remove all gages and replace all plugs or caps. Recheck fluid levels after 15 minutes and add as necessary to bring to level of sight eyes in each tank.

Hopper Gate Adjustment

1. Place the auto/park/manual selector in "PARK."

2. Disconnect the g/b wire from each solenoid of the gate valve.

3. Start the engine and run it at about 1500 rpm.

4. Using the manual overrides on the gate solenoid valve, close the gates fully. There should be $\frac{1}{16}$ " between the gates and the spread roll.

5. Shut the engine off and install a 1500 psi pressure gage in the gate circuit.

6. Reconnect the g/b wire to each solenoid of the gate valve.

7. Disconnect the 16 pin connector from the main control box.

8. Check the resistance across sockets 5 & 6. The value should be nominally 18K ohms \pm 3K with the pedal up and 0 to 10 ohms with the pedal fully depressed. This is the gate circuit.

Also check the resistance across sockets 3 & 4. This value should also nominally be 18K ohms \pm 3K with the pedal up and 0 to 10 ohms with the pedal fully depressed. This is a part of the auto speed circuit. Remove the floor plate to the right of the seat pivot and open the junction box. Remove the or/g wire that goes forward from terminal 13, remove the or/b wire that goes forward from terminal 14 and remove the or wire that goes forward from terminal 15. Check the resistance across the or/g and or/b wires. This value should be between 930 and 1100 ohms. If it measures within this range, reconnect the wires to their respective terminals. The value between the or/b and or wires should be less than 20 ohms.

9. Reconnect the 16 pin connector to the main control box.

If no components have been changed, skip step 10 and proceed directly to step 11.

10. Open the main control box. The gate board is mounted on the side of the control box. There are five adjustment pots on the board, all of which have

been factory set to an initial position. These initial positions are listed here for reference. Do not move from these initial positions before attempting to adjust the gate.

- Filter—full ccw +11 turns
- Close—full ccw +11½ turns
- Open—full ccw +8¼ turns
- Sensitivity—full ccw +5 turns
- Override—full ccw +19 turns

It should not be necessary to verify these initial positions, the adjustment procedure is normally started from these positions. If it is necessary to check these the pot should be rotated in the ccw direction until a click is heard. There is no stop, you must listen for a slight clicking noise to know when you are fully to the end of electrical travel.

If the value measured across the or/b and or wires and the or/g and or/b wires in step 8 above was within the acceptable range, skip steps 11 through 14 and proceed directly to step 15.

11. Remove the transducer guard located under the radiator cover.

12. Loosen the locking hub on the 72T pulley (Figure 32) until it is free.

13. Rotate the transducer to obtain a reading within the range and retighten the locking hub on the 72T pulley.

14. Recheck the reading and reconnect the wires to their respective terminals.

15. Turn the ignition key to the on position but do not start the engine.

16. Turn the gate opening set point on the main control box fully counterclockwise and turn the thumb switch on the handle off.

17. Adjust the “close” trim pot on the gate board, until both the green and red LED’s are blinking at about the same intensity. (CCW opens gate, CW closes gate.)

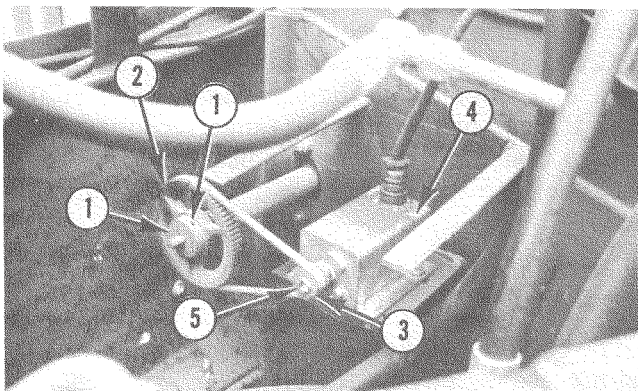

Figure 32. Gate Opening Transducer

- | | |
|---------------|---------------------|
| 1. Set Screws | 4. Transducer |
| 2. 72T Pulley | 5. Screwdriver Slot |
| 3. 16T Pulley | |

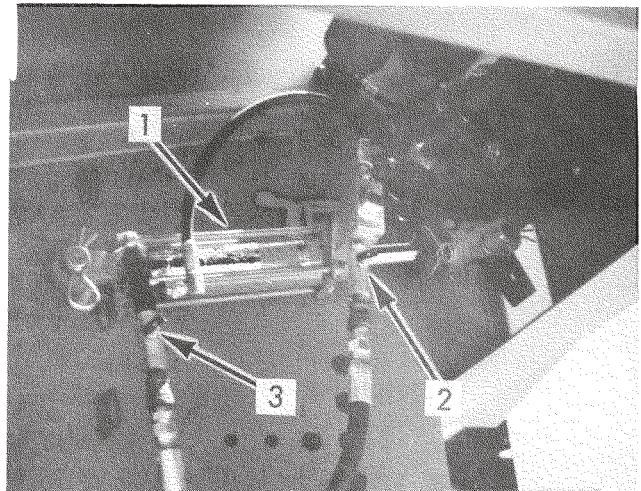

Figure 33. Gate Actuation Cylinder

(located under conveyor - right side, front)

- | | |
|-------------------------------|-------------------------------|
| 1. Gate Actuation Cylinder | 3. Opening Speed Flow Control |
| 2. Closing Speed Flow Control | |

18. Start the engine and run it at approximately 1500 rpm. Set the gate opening to 4” (fully clockwise) and turn the thumb switch on the handle on. Adjust the “open” trim pot to obtain a true 4” opening measured at the gate, and be sure that both LED’s are blinking at about the same intensity. (CCW opens gate, CW closes gate.) Verify with the pressure gage that the pressure is 0 at both the full open and the closed position and adjust as necessary to achieve this.

19. Run the engine at full rpm (approximately 2300 rpm).

20. Set the gate opening to a setting of 2”. Repeatedly open and close the gate to this opening while adjusting the “sensitivity” counterclockwise until the onset of “hunting” occurs and then adjust the “filter” counterclockwise very finely until the “hunting” is eliminated. (CCW increases sensitivity, CW decreases sensitivity.) (CCW increases filtering, CW decreases filtering.)

21. Recheck the closed position for equally blinking LED’s and readjust slightly if necessary to obtain this.

22. Recheck the open position for 4” opening and also for equally blinking LED’s and readjust slightly if necessary.

23. Check for repeatability of the gate setting. It should be within $\pm 1/16$ ”. Check that with a setting of ½” the gate will open. If it does not, adjust the “filter” slightly cw until it does and then adjust the “sensitivity” slightly clockwise if necessary to eliminate “hunting” and then recheck the repeatability.

24. Turn the thumb switch on and adjust the gate opening to approximately 1¼” and depress the override button. Adjust the override pot to obtain a 4”

opening and verify that the gate is not opening too far by having 0 pressure while holding down the override button. (CCW opens gate, CW closes gate.)

25. Return the engine to idle and shut it off.

26. Reinstall the transducer cover and reclose the radiator cover. Reclose the junction box under the floor plate and reinstall the floor plate. Remove the pressure gage.

Brake Adjustment

Front Brake Adjustment (2 WD Only)

CAUTION

Before starting, securely chock the chipspreeder wheels to prevent accidental movement of chipspreeder.

Before beginning any adjustments to the operating mechanism under this section, the front wheel brake shoes must be adjusted for a slight drag on each front wheel. This is done by first jacking up and supporting the chipspreeder securely on stands.

1. Remove oblong rubber caps and use brake adjusting tool to rotate ratchet wheel until a slight drag is felt when the wheel is rotated by hand. Adjust both front wheels to about the same drag.

2. Bleed the front brake lines.

3. Place range selector switch in "lo." (Fig. 6)

4. Place Auto/Park/Manual switch in "Manual."

5. Start and run engine at about 950 RPM.

6. Open flow control on rod end of slave cylinder fully.

7. Depress override pedal slowly until all wheels stop rotating. With pedal held in that position, adjust the micro switch roller so that it just trips the switch. (Figure 36)

8. Adjust flow control so that slave cylinder takes 2 to 3 seconds to extend. Its retract speed is not adjustable.

9. Remove stands and test drive Chipspreeder. With rapid movement of the stick into neutral or rapid depression of the override pedal, the pump should destroke before the front brakes come on. However, the front brakes should come on as soon as practical after the Unit has stopped.

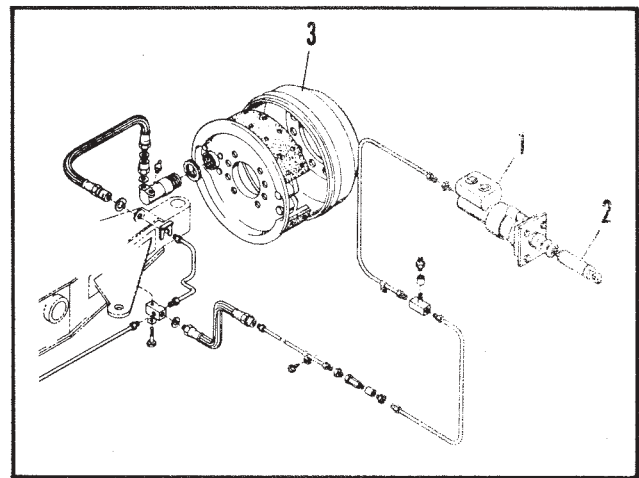

Figure 34. Front Brake - 2WD

1. Brake Reservoir 2. Slave Cylinder 3. Right Front Wheel

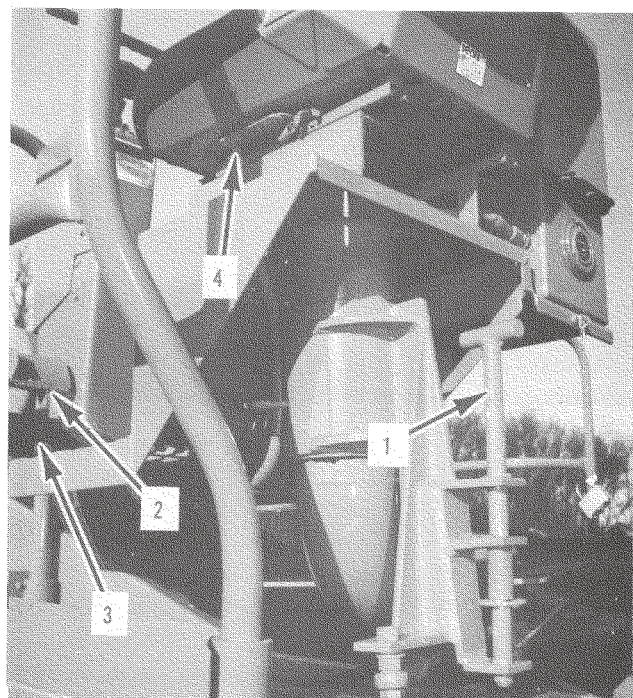

Figure 35.

1. Lock Pin
2. Override Pedal
3. Left Side Potentiometer Location
4. Seat Adjust Lever (Fore & Aft)

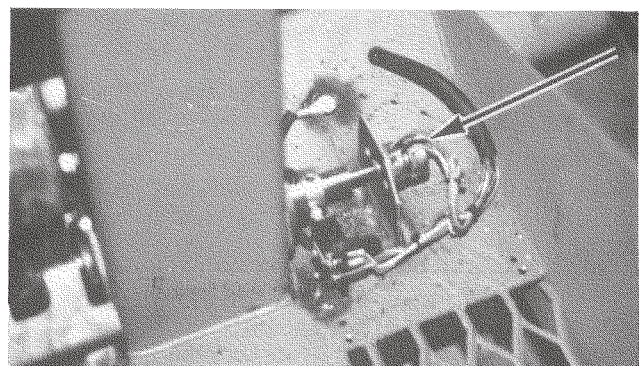

Figure 36. Limit Switch

1. Override Pedal 2. Limit Switch

Rear Brake Adjustment

CAUTION

Before starting, securely chock the chipspreader wheels to prevent accidental movement of chipspreader.

1. Disconnect the pump stroker connector at the pump.
2. Start engine and run at approximately 1000 RPM.
3. Be sure to place auto/park/manual selector in manual.

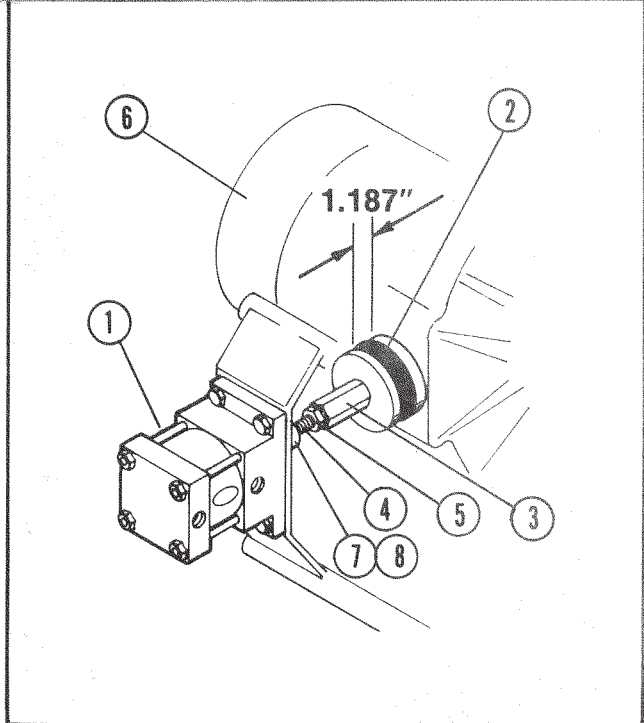
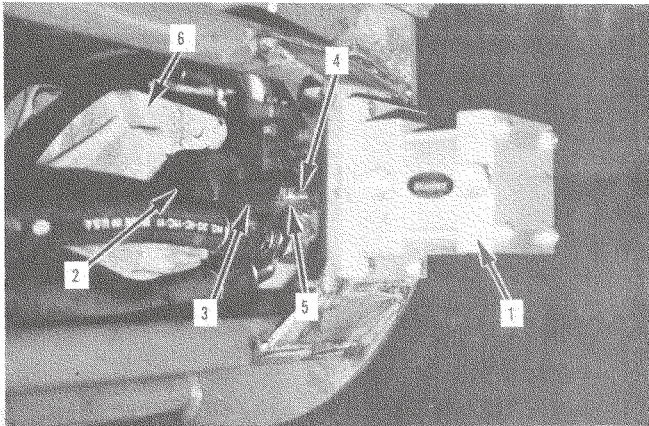

Figure 37. Brake Cylinder - 2WD and 4WD (Right Side Shown)

- | | |
|-----------------------|---------------------------|
| 1. Brake Cylinder | 5. Lock Nut |
| 2. Elastomer Spring | 6. Wheel Motor |
| 3. Hex Brake Adjuster | 7. Adjusting Bolt Locator |
| 4. Adjusting Bolt | 8. Locator Locknut |

4. Place range selector in "lo."

5. Push stick forward slightly. Chipspreader should not move but brakes should release. (Brake cylinders should extend fully. Figure 37)

6. Put the stick in neutral. Cylinders should retract approximately 0.2" with new brakes. With the cylinder forced back to its fully retracted position, there should be a 0.8" between the end of the cylinder rod itself and the top of the adjusting bolt on the spring adjuster.

7. Cycle the brakes "on" and "off" a few times to make sure that all air has been removed and that the brakes are applying simultaneously.

8. Place the stick in neutral thus applying the brakes. With the brakes applied, the elastomer springs should be adjusted equally to a dimension of 1.187" to 1.200" from end to end.

9. Cycle the brakes "on" and "off" a few times and recheck this dimension on each side. When properly adjusted, tighten down locknuts.

It should be noted that the 1.187" to 1.200" dimension will increase with brake wear and will require adjustments to keep at that dimension. The elastomer spring will take a set with time and lose some of the applied braking force. About ½ turn clockwise of the hex adjuster will restore the full braking force. The adjusting bolt that extends toward the cylinder out of the top of the adjuster must be backed out the same amount the adjuster was turned in in order to insure proper brake release and the locknut retightened. To insure that proper braking force is available, the elastomer springs should be changed once a year.

If the brakes appear to be dragging, do not raise the brake release pressure. First, check that the cylinder is extending 0.2", if it is not then check that with the cylinder forced back to its full retracted position, there is 0.8" between the top of the bolt head and the cylinder rod proper. If there is not, then adjust the bolt to get that dimension. If there is, then loosen the hex adjuster ¼ turn and screw the bolt in ¼ turn to keep the proper clearance and try the brakes again.

When changing the springs, so as not to disturb the fully extended cylinder adjustment, unbolt the cylinder from the mount and slide it forward out of the mount and then unscrew the adjuster from the brake rod, install a new spring and tighten the adjuster to compress the elastomer spring to 1.187" to 1.200" height. It should also be noted that if the control stick is moved into neutral rapidly, the brakes will come "on" before all hydrostatic braking has normally brought the machine to a halt, thus causing premature wear of the discs and requiring more frequent adjustment.

10. Place stick in neutral and shut "off" ignition.
11. Reconnect 16 pin connector.

Tach Calibration

1. Turn ignition key "on" with engine not running.
2. Hold "select" switch down until "cal" is displayed (approx. 10 seconds).
3. Release "select" switch to display present alternator setting.
4. Push and release "select" switch to advance alternator setting.
5. When desired alternator setting is displayed, hold switch down until "cal" is redisplayed (approx. 10 seconds). This stores the new setting into memory.
6. When switch is released, new alternator setting is displayed for approximately 10 seconds.
7. Digital instrument panel will automatically reset for normal operation.

NOTE: Once unit is calibrated, recalibration is not necessary upon restart unless the chipspreader batteries have been disconnected.

Setting No. 2 Caterpillar 3208 series engines.

Setting No. 3 Cummins 6BT or 6BTA (12 pole alternator).

Setting No. 4 GMC 4.53 (12 pole alternator).

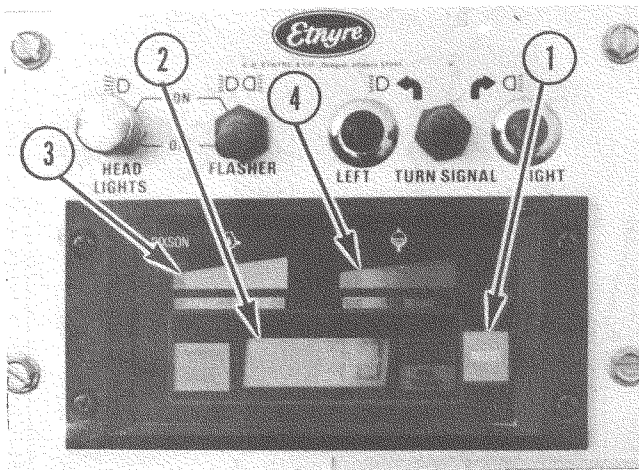

Figure 38. Digital Instrument Panel

1. "Select" Switch
2. Digital Display Area
3. Bargraph - Engine Oil Pressure
4. Bargraph - Engine Coolant Temp.

Powered Seat Speed Adjustment

1. Seat speed adjustments must be made with the engine at governed speed.

2. The range selector must be in either "lo" or "2nd."
3. Loosen the flow control locknuts (Fig. 39).
4. Retract the lock pin at the rear of the seat (Fig. 40).
5. Since each flow control sets the speed in one direction only, it is necessary to adjust the rotation speed in one direction with one valve and the rotation speed in the opposite direction with the other valve.
6. With the engine at governed speed, the speed being set will be the maximum speed that the seat will move. Adjust for a comfortable maximum speed and for equal speed in both directions.
7. Note that this speed will only be available at governed speed and as engine RPM is lowered, the seat will move slower. At about 1100 RPM the seat may no longer move.
8. When the speed has been satisfactorily adjusted, retighten the lock nuts while holding the stem of the flow control valve.
9. The seat also has a fore and aft seat adjustment operated by a pull lever under the left side of the seat.

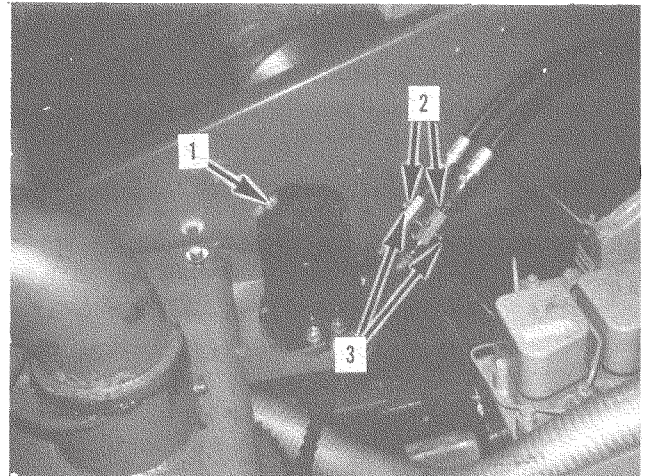

Figure 39. Power Seat Adjustment

1. Motor-Seat
2. Flow Controls
3. Locknuts

Override Pedal Adjustment

Before beginning any adjustments to the operating mechanism under this section, the chipspreader must be jacked up and securely support on stands.

Warning: Be certain that machine is securely supported on stands. Wheels will be rotating under power and if they contact the ground or debris becomes lodged between the wheels and ground, the chipspreader could drive off the stands.

Left Side Potentiometer—Manual

(Fig. 40, Ref. 1)

1. Place auto/park/manual selector in “manual.” (Figure 3).

2. Place speed range selector in “lo.”

3. Check the resistance across sockets 1 & 2. The value should nominally be 0 to 10 ohms with the pedal up and 350 ohms with the pedal down. It should become an open circuit just as the pedal is fully depressed. If it does not, or it opens much before the pedal is fully depressed, adjust the limit switch cam so that the contacts open just as the pedal is fully depressed. This will turn off the manual command to the pump as the other switch on the right side applies the rear brakes.

WARNING

Be certain that machine is securely supported on stands. Wheels will be rotating under power.

Right Side Potentiometer—Auto

(Fig. 40, Ref. 4)

1. Place auto/park/manual selector in “auto.” (Figure 6)

2. Place speed range selector in “lo.”

3. Disconnect the rear 16 pin connector from the control box.

4. Check the resistance across sockets 5 & 6. The value should be nominally 18K ohms \pm 3K with the pedal up and 0 to 10 ohms with the pedal fully depressed. This is the gate circuit.

Also check the resistance across sockets 3 & 4. This value should also nominally be 18K ohms \pm 3K with the pedal up and 0 to 10 ohms with the pedal fully depressed. This is a part of the auto speed circuit. If the gates are properly set do not move this pot.

5. Inside the control box, disconnect the blue wire on terminal 7 of the auto speed controller.

6. Adjust the trim pot attached to the wiper terminal of the auto speed command pot to a value equal to approximately $\frac{1}{4}$ of the value measured across terminals 3 & 4 of the connector measured in step 4 of the right side pedal adjustment. Reattach the blue wire to terminal 7 of the auto speed controller.

7. Reconnect the 16 pin connector.

8. Turn on the ignition key but do not start the engine.

9. Place the auto/park/manual selector in “auto”

and turn the speed command pot full clockwise. Push the handle out of neutral in the forward direction and measure the voltage between terminals 7 & 3 of the auto speed controller. The voltage should be 2.92 volts with the pedal up. If it is not, adjust the trim pot on terminal 6 of the auto speed controller to get this voltage.

10. Depress the pedal fully and measure the voltage between terminals 7 & 3. It must be less than 0.16 volts.

11. The limit switch with the r/b and w/r wires on it is the switch which releases the rear brakes. It should be set so that its contacts open the circuit just at the very bottom of the pedal stroke thus applying the brakes. There should be electrical continuity across sockets 10 & 11 when the pedal is up and when the pedal is fully depressed this continuity should be interrupted.

12. The limit switch with the g/w wire is the switch which turns the spread roll off as the gate is fully closed by interrupting the spread roll valve's ground connection. It should be set so that its contacts open the circuit very near the bottom of the pedal stroke. There should be electrical continuity from socket 12 to ground when the pedal is up and when the pedal is fully depressed this continuity should be interrupted.

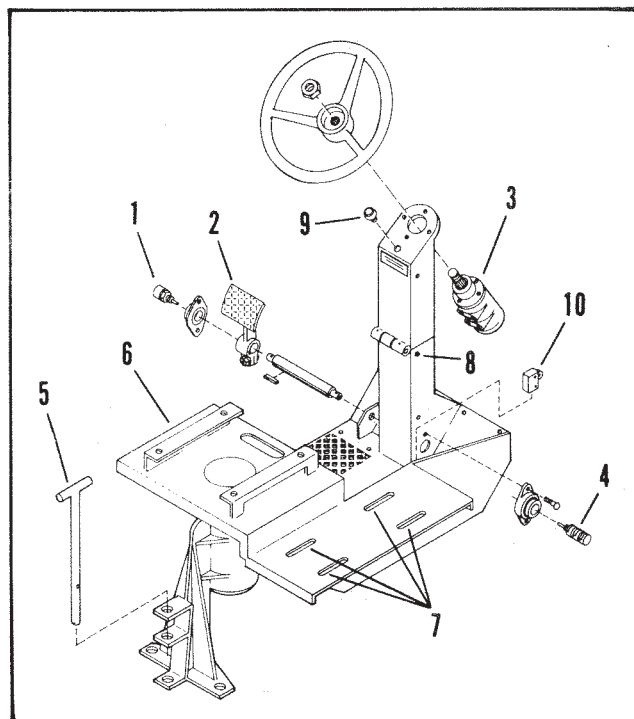

Figure 40. Override Pedal Adjustment

- | | |
|-----------------------------|---|
| 1. Left Side Potentiometer | 6. Operator Seat Assembly |
| 2. Override Pedal | 7. Control Box Fore/Aft Adjustment Slot |
| 3. Power Steering Control | 8. Tilt Wheel Adjustment Bolts |
| 4. Right Side Potentiometer | 9. Warning Light |
| 5. Seat Latch Pin | 10. Switch |

Seat Chain Adjustment (Fig. 41)

1. Remove left floor plate alongside pivot arm.
2. Loosen locknuts and adjust jackscrew to adjust chain for proper tightness.
3. Retighten nuts and reinstall floor plate.

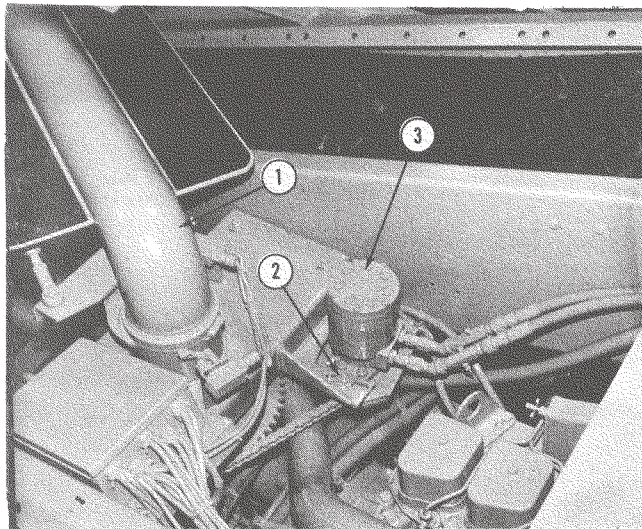

Figure 41. Seat Chain Adjustment

1. Seat Pivot Arm 2. Locknut 3. Seat Pivot Motor

TOWING INSTRUCTIONS

If the engine is runable and pressure is available in the control pressure circuit, place the auto/park/manual selector in "manual" place the range selector in "travel," start the engine and push the stick out of neutral slightly in the direction to be towed, in order to release the brakes. The chipspreader should only be towed to the side of the road or onto a trailer.

There must be electric power to the control box in order to freewheel the front motors. If the chip-spreader batteries are dead, an auxiliary battery must be hooked to them in parallel to provide electric power to the control box.

If the engine is not runable, there is no power steering or pressure in the hydraulic control system. The key must be turned on to provide electric power, **the range selector must be in "travel"** to free wheel the front motors, auto/park/manual selector must be in "manual," the control handle must be out of neutral and the rear brakes must be released by the following procedure.

CAUTION

The following procedure will release the brakes and may allow the chipspreader to roll! The chipspreader must be hooked to the tow vehicle or otherwise secured before proceeding further.

IMPORTANT

Do not tow the chipspreader before reading the towing instructions contained in this manual. Improper towing may damage the hydraulic motors.

CAUTION

The front hopper should be fully closed up and latched when the unit is traveling between job sites to avoid possible damage to the outer ends of the hoppers.

Disconnect the 1/4" feed hose at the tee which then feeds to both brake cylinders. (See Figure 42 on the following page.) Cap the hose temporarily to keep dirt out and stop fluid from draining. Insert the output hose from an Enerpac or Portapower into the tee. Be sure to use a long enough hose to allow the pumping device to be operated from alongside or on the chipspreader (where the operator can observe the brake cylinders while pumping) and pump, watching the brake cylinders until fully extended thus releasing the brakes.

The towing capabilities of the machine are not intended for any appreciable distance, but to be able to move it to a safely parked location where it may be worked on or from which it may be loaded onto a trailer for transportation to a suitable shop.

Hookup and tow, not exceeding 15 mph.

REAR WHEEL DRIVE SYSTEM - 2 WHEEL DRIVE

REMOVE HOSE A

CONNECT PORTAPAC TO TEE B

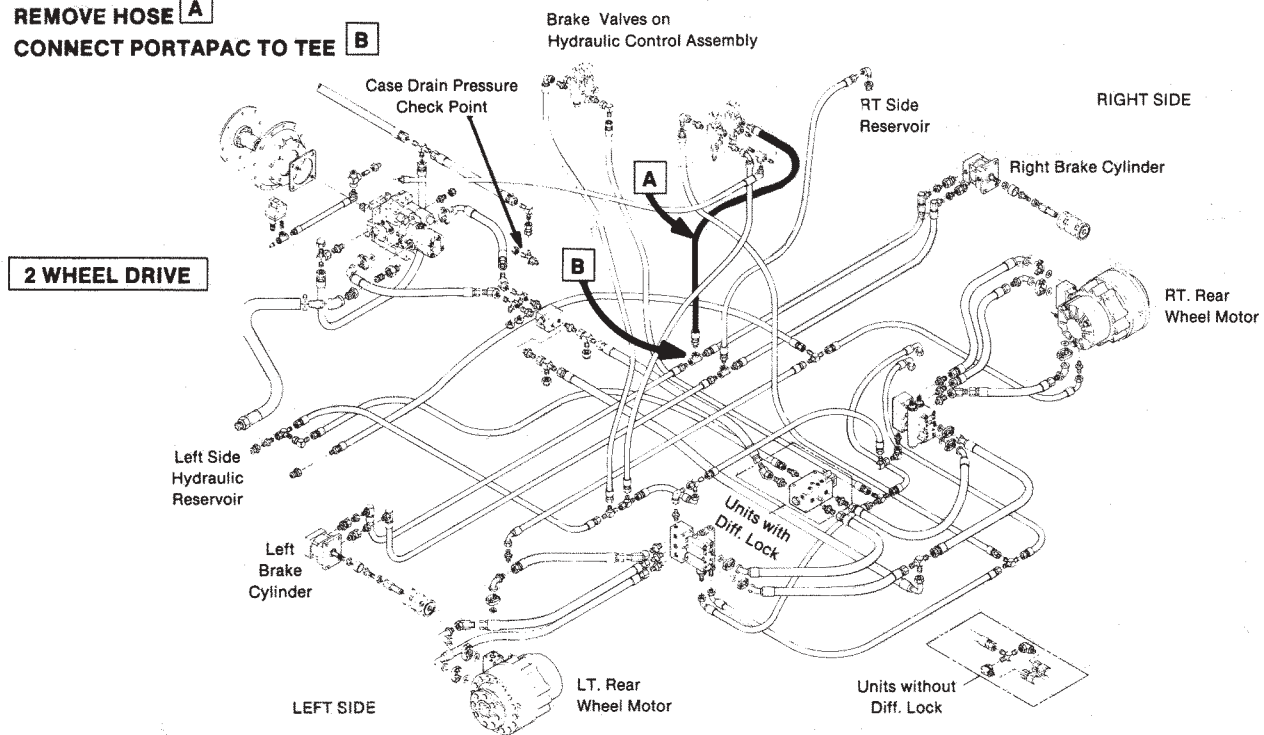

REAR WHEEL DRIVE SYSTEM - 4 WHEEL DRIVE

REMOVE HOSE A

CONNECT PORTAPAC TO TEE B

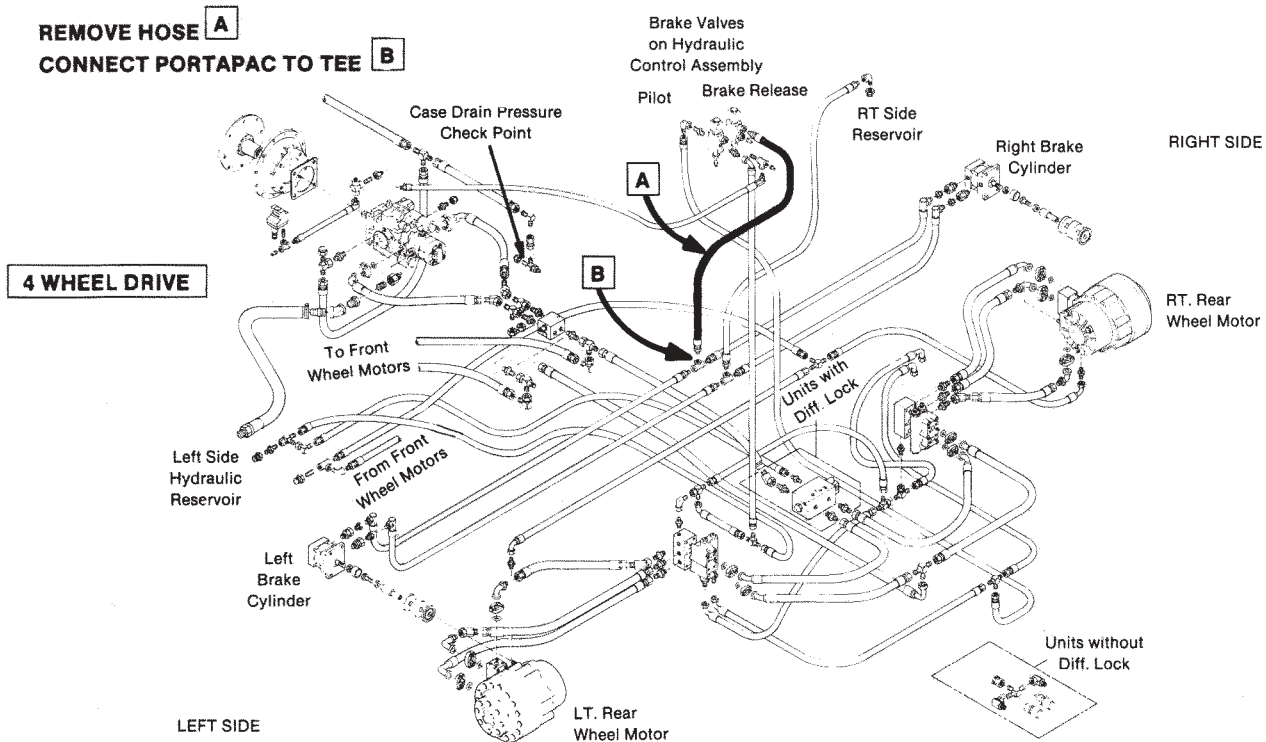
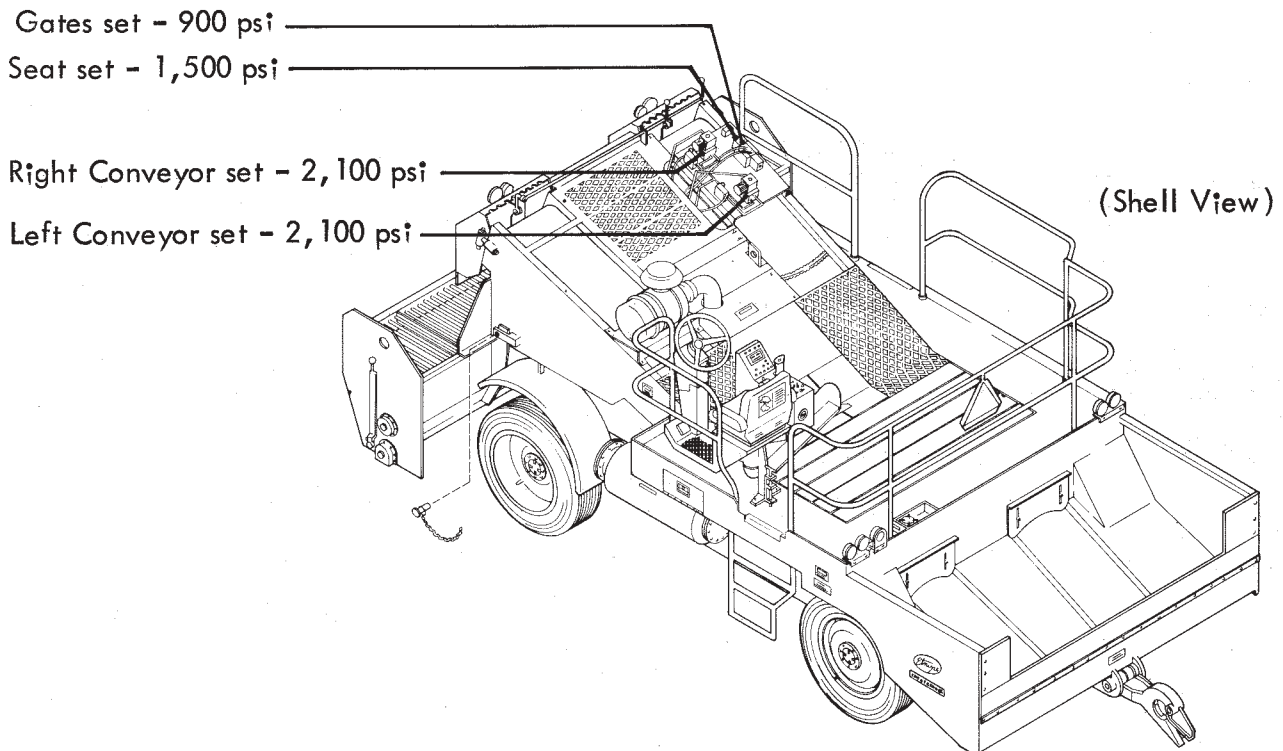
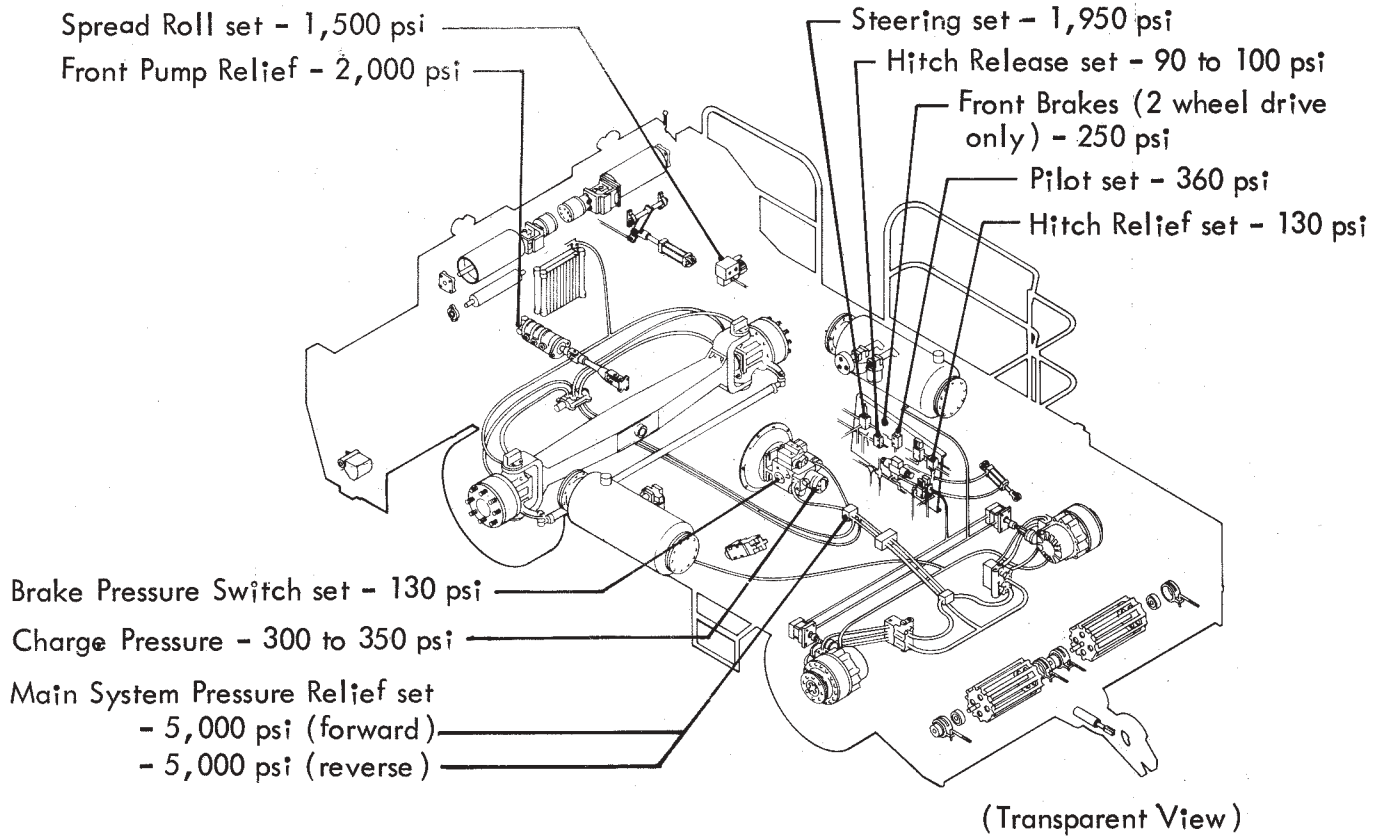
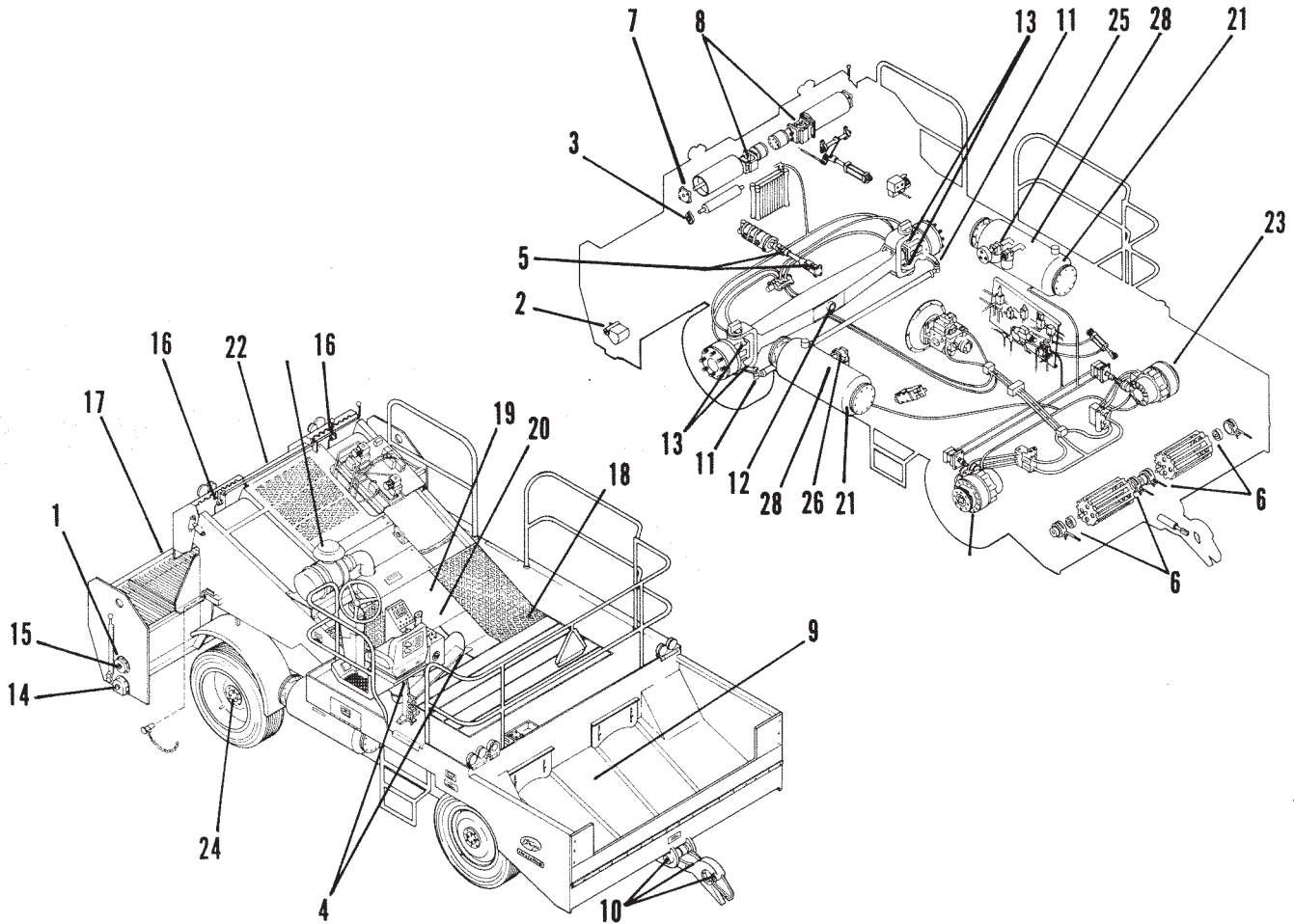

Figure 42. Portapower Connection for Brake Release

HYDRAULIC PRESSURE SETTINGS
Hydrostatic Chipspreader with standard hopper



LUBRICATION



Interval	Point	Identification	No. of Points	Lubricant	Quantity
Weekly	1	Bearing-Disconnect	1	#2M-AG	Sparingly
	2	Front Hopper Gates	A/R	#2M-AG	Sparingly
	3	Return Idler Flange Bearing (Both Conveyors)	4	#2M-AG	Sparingly
	4	Seat Pivots	4	#2M-AG	Sparingly
	5	Universal Joints-Pump Driveshaft	2	#2M-AG	Sparingly
	6	Tail Pulley Bearings (Both Conveyors)	4	#2M-AG	Sparingly
	7	Flange Bearings (Both Conveyors)	4	#2M-AG	Sparingly
	8	Double Universal Joint (Both Sides)	4	#2M-AG	Sparingly
	9	Rear Hitch Levers	2	#2M-AG	Sparingly
	10	Rear Hitch	4	#2M-AG	Sparingly
	11	Tie Rod	2	#2M-AG	Sparingly
	12	Center-Axle Pivot Shaft	1	#2M-AG	Sparingly
	13	Spindle Assembly (Both Sides 4wd only)	4	#2M-AG	Sparingly
	14	Cartridge Bearing (Both Ends)	2	#2M-AG	Sparingly
	15	Cartridge Bearing (Both Ends)	2	#2M-AG	Sparingly
	16	Baffle Shaft (Both Hoods)	2	#2M-AG	Sparingly
	17	Gate Latch Control Handle	A/R	#2M-AG	Sparingly
	18	Engine Battery	1	Water	Add When Low
	19	Engine Oil	1	Engine Original	Engine Manual

Interval	Point	Identification	No. of Points	Lubricant	Quantity
Check Weekly	20	Master Brake Cylinder-2wd only	—	Brake Fluid	Fill
	21	Hydraulic Reservoirs	—	Type HTF	Fill
	22	Hydraulic Oil Coolers	—	—	Clean A/R
1 Year	24	Wheel Bearings Front-2wd only	—	#90M-ATG	Fill To Bottom Of Plug
	25	*Return-Filter	1	—	Filter Element
	26	*Suction Filter	2	—	Filter Element
When Indicator Turns Red	27	Engine Air filter	1	—	Filter Element
Yearly	28	Reservoir Breather	1	—	Filter Element

*On new machines change return line filter elements after first two weeks of operation. After initial change (two weeks) replace elements on an annual basis unless hydraulic system has been worked on and contamination introduced into the system. Change filter elements anytime it is possible that contamination had been introduced into the System.

**Brake Fluid conforming to DOT 3, DOT 4, DOT 5, or SAE J-1703. Manufacturers include Dowe Corning and Wagner.

#10ND Oil—#10 Non-Detergent Oil #90M-ATG—#90 Molub-Alloy
 Type HTF—Type A Transmission Fluid Transmission
 #2M-AG—#2 Molub-Alloy Grease Lubricant

TRUCK HITCH ARRANGEMENT

1. Trucks ranging in size from four to ten yards are handled easily by an ETNYRE Chip-Spreader.

2. An apron on the rear of each truck will be quite helpful.

3. For truck hitch arrangement, see truck hitch tow bar illustration below.

Truck Hitch Tow Bar Illustration

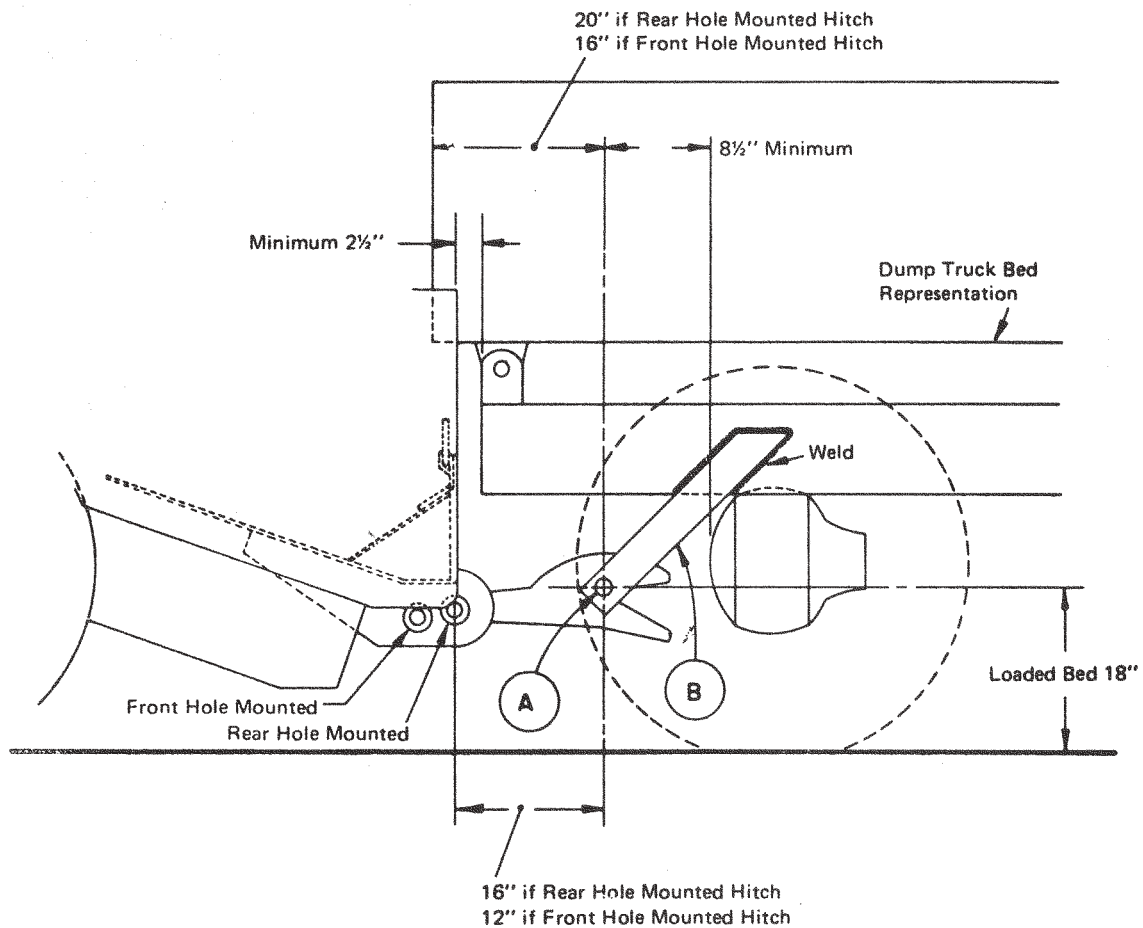

A. 3390451-Cold Rolled Round 1 3/4" dia. x 36" long

B. 3390450-Hot Rolled Flat 1/2" x 4" x 18" long (2) Req'd

CAUTION and INSTRUCTION PLATES

- ⚠ For operator safety and possible liability protection, all Safety and Instruction plates should remain in place and be legible.
- ⚠ Should a plate be removed, lost, or become illegible, Reorder and Replace Immediately.
- ⚠ If plates become difficult to read because of material coating the surface, clean with solvent.

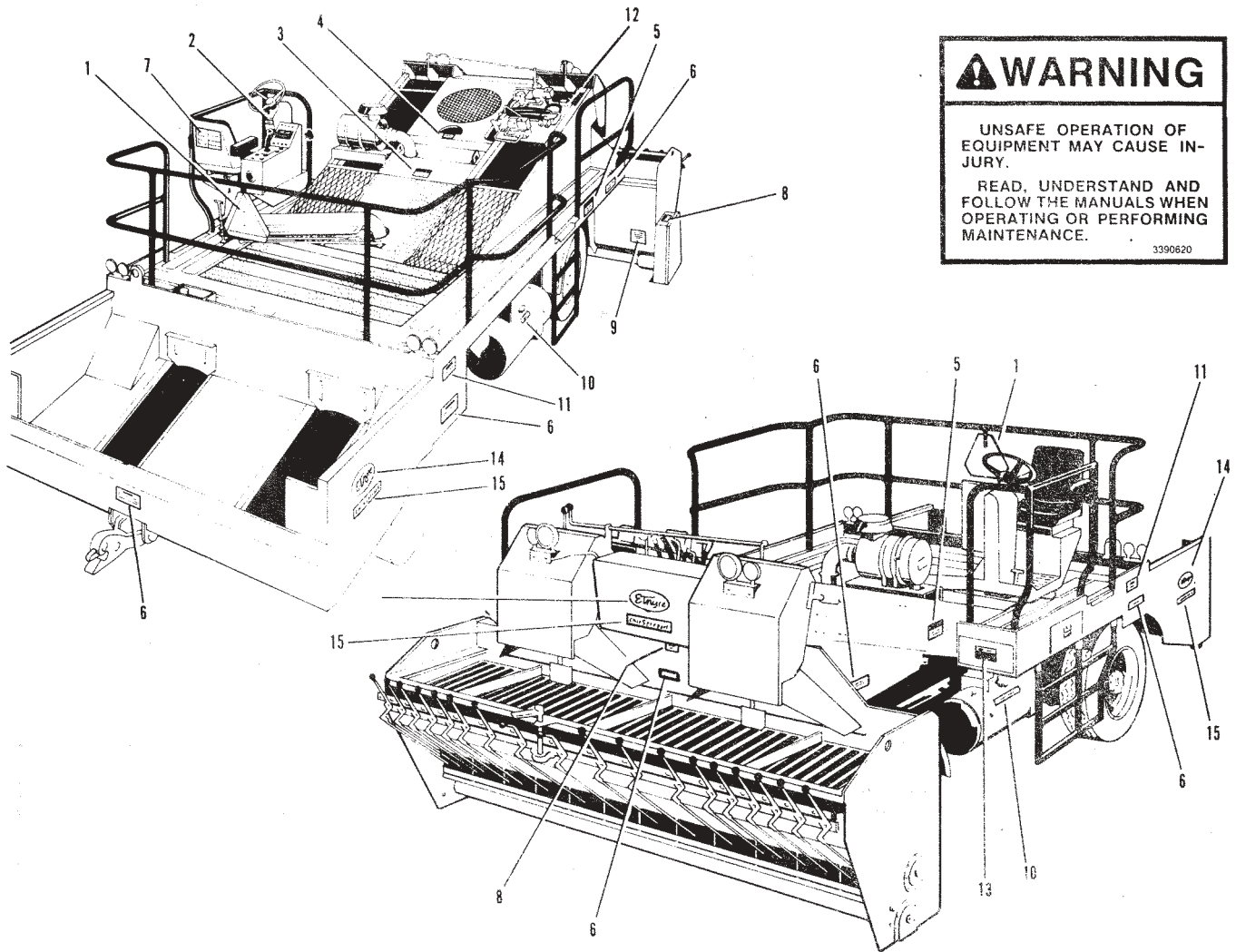

REF.	PART NO.	QTY.	DESCRIPTION	REF.	PART NO.	QTY.	DESCRIPTION
1	6000758	1	EMBLEM-VEHICLE, SLOW MOVING	11	3101247	2	PLATE-WARNING, NO DRILL OR WELD
2	3390620	1	PLATE-WARNING, READ MANUALS	12	3101268	1	PLATE-HYDR. HITCH RELEASE
3	3100716	1	PLATE-CAUTION, CHIPSREADER, GEN	13	3100689	1	NAME PLATE-CHIPSREADER, BRASS
4	3100766	1	TAG-ANTI-FREEZE	14	3390191	3	DECAL-OVAL, ETNYRE
5	3561028	2	PLATE-CAUTION, REMAIN CLEAR	15	3100446	3	DECALS CHIPSREADER
6	3101652	7	PLATE-HYDRO, TOWING WARNING				
7	3101452	1	CHART-2WD&4WD LUBRICATION, CHIP				
8	3561029	2	PLATE-CAUTION, SHIELDS				
9	3190476	1	LABEL-SPREAD HOPPER, HOSE ATTCH				
10	3390605	2	PLATE-INSTR. HYDRAULIC OIL SPEC				