

M-114-12R1

Supersedes M-114-12R

Serial Numbers S5612 & up
with BT 1 Controls
Version 4.5 & Up

Updated June 19, 2014



Black-Topper® CENTENNIAL Asphalt Distributor With BT 1 Controls

For Units with Variable Width Spray Bar



Operation



Maintenance



Safety



E.D. ETNYRE & CO. – 1333 S. Daysville Road – Oregon, Illinois 61061
Phone: 815-732-2116 or 800-995-2116 – Fax: 800-521-1107 – www.etnyre.com

M-114-12R1

Black-Topper Centennial Operation, Maintenance, and Safety Manual

BLACK-TOPPER Distributor with Variable Width Spraybar and BT-1 Controls

Version 4.5 & up

Serial Numbers S5612 & up

Updated June 19, 2014

WARRANTY

E. D. Etnyre & Co. warrants to the original Purchaser, its new product to be free from defects in material and workmanship for a period of twelve (12) months after date of delivery to original Purchaser. The obligation of the Company is limited to repairing or replacing any defective part returned to the Company and will not be responsible for consequential damages or any further loss by reason of such defect.

The company excludes all implied warranties of merchantability and fitness for a particular purpose. There are no warranties, express or implied, which extend beyond the description of the goods contained in this contract.

This warranty does not obligate the Company to bear the cost of machine transportation in connection with the replacement or repair of defective parts, nor does it guarantee repair or replacement of any parts on which unauthorized repairs or alterations have been made or for components not manufactured by the Company except to the extent of the warranty given by the original Manufacturer.

This warranty does not apply to:

- (1) Normal startup services, normal maintenance services or adjustments usually performed by the selling dealer, factory service representative or customer personnel.
- (2) Any product manufactured by E. D. Etnyre & Co. purchased or subjected to rental use.
- (3) Any product or part thereof which shows improper operation, improper maintenance, abuse, neglect, damage or modification after shipment from factory.
- (4) Any product or part thereof damaged or lost in shipment. Inspection for damage should be made before acceptance or signing any delivery documents releasing responsibility of the delivering carrier.

This warranty and foregoing obligations are in lieu of all other obligations and liabilities including negligence and all warranties of merchantability or otherwise, express or implied in fact or by law.



WARNING

Do not use this machine for any operation that is not described in this manual.

If you have any questions about operation of this machine, contact the Etnyre Service Department at 1-800-995-2116 or 1-815-732-2116.

Operations that are not approved could cause serious injury or death.



WARNING

Diesel engine exhaust and some of its constituents are known to the State of California to cause cancer, birth defects, and other reproductive harm.

Please note this warning and remember:

- Always start and operate the engine in a well ventilated area.
- If in an enclosed area, vent the exhaust to the outside.
- Do not modify or tamper with the exhaust system. Can cause serious injury or death.

© Copyright 2011 E.D. Etnyre & Co.
All brand names, trademarks and registered
trademarks are the property of their respective
owners. Information contained within this
document is subject to change without notice. All
rights reserved.

Table of Contents

Safety Instructions		CIRCULATING	32
Warning And Instruction Plates.....	5	Circulating in the Tank.....	32
General Safety Instructions.....	7	Circulating Product in the Bar.....	34
Safety Precautions, Hazard Seriousness Level.....	7	SPRAYING	36
WARNINGS	8	Spraying Through the Bar.....	36
Fluoroelastomer Handling.....	8	Hand Spraying.....	37
Foaming.....	10	SUCKBACK	38
Asphalt Institute.....	10	Spray Bar Suckback.....	38
Introduction	11	Suck Back Override.....	40
Reporting Safety Defects.....	11	Handspray Suckback.....	41
Component Location And Identification.....	12	FLUSHING OPERATIONS	42
Rear and Side Components.....	12	Bar Flush (Auto).....	42
Spray Bar Components.....	13	Bar Flush (Manual).....	43
Hydraulic Tank Components.....	13	Enviro-Flush System (OPTIONAL).....	44
Cab Control Panel.....	14	Recycle Enviro-Flush.....	45
Cab Control Panel Descriptions.....	14	UNLOAD OPERATIONS	46
Rear Control Panel.....	16	Unload Operations with External Pump.....	46
Rear Control Panel Descriptions.....	16	Unload Operations with Distributor Pump....	48
Preparing for Operation	19	TRANSFER OPERATIONS	50
Setting Up the Computer.....	19	Heating Product in Distributors	52
First Screen.....	19	<i>Heating w/ Propane Burners</i>	52
Second Screen.....	19	Propane Requirements.....	52
Third Screen.....	19	Manual Ignition Control.....	53
Fourth Screen.....	20	Ignition and Out Fire Control.....	54
Fifth Screen.....	20	Thermostatic Control.....	56
Sixth Screen.....	20	<i>Heating w/ Fuel Oil Burners</i>	57
Seventh Screen.....	20	Ignition and Out Fire Control.....	58
Eighth Screen.....	20	Thermostatic Control.....	59
Engaging Pump on PTO Equipped Distributors.....	21	Troubleshooting	60
Manual Transmissions.....	21	Maintenance	62
Automatic Transmissions.....	21	Gun Assembly.....	62
Spraying Operations.....	22	Electrode Settings.....	62
Setting the Digital Memory Presets.....	23	Check Ignition Transformer Spark.....	63
Adjusting the Spray Bar Nozzle Angle.....	23	Fire Burners.....	63
Adjusting the Spray Bar Height.....	23	Replacing Speed Pickup.....	63
Spraying Through the Bar.....	23	Servicing the Etnyre P-15 Pump.....	64
Operation	25	Vacuum Check.....	64
Tank Capacity.....	25	Pump Disassembly And Inspection.....	64
Operation Screens.....	25	Impeller Installation And Pump Assembly...	64
First Operating Screen.....	25	General Fuel Data and Heating Terminology...	65
Second Operating Screen.....	25	Fuel Data.....	65
Third Operating Screen.....	26	Approximate Burner Fuel Consumption.....	65
Information Messages.....	26	Heating Terminology.....	65
LOADING	28	Hydraulic Fluid Requirements.....	66
Loading Through the Manhole.....	28	General Information.....	66
Loading Through the Load Line.....	29	Hydraulic Fluid Requirements.....	66
Connections and Preliminary Checks.....	29	Viscosity & Temperature Requirements.....	66
Check Strainers.....	29	Contamination Levels.....	67
Using the Measuring Stick.....	29	Lubrication Chart.....	69
Loading Through the Load Line (cont).....	30	Etnyre Spraybar Nozzles.....	70
		Decimal Equivalent Chart.....	71

List of Illustrations

Figure 1. Location of Warning and Instruction Plates.....	5
Figure 2. Rear and Side Component Identification.....	12
Figure 3. Rear Component Identification.....	12
Figure 4. Spray Bar Component Identification.....	13
Figure 5. Hydraulic Tank Component Identification.....	13
Figure 6. Cab Control Panel Components.....	14
Figure 7. Rear Control Panel Components.....	16
Preparing for Operation	
Figure 8. Adjusting the Spray Bar Nozzles.....	23
Figure 9. Adjusting the Spray Bar Height.....	23
Figure 10. Selector Valve set to Normal Spraying.....	23
Operation	
Figure 11. Valve Positions for Loading Through the Manhole.....	28
Figure 12. Using the Measuring Stick.....	29
Figure 13. Valve Positions for Loading Through the Load Line.....	30
Figure 14. Valve Positions for Circulating in the Tank.....	32
Figure 15. Valve Positions for Circulating in the Bar.....	34
Figure 16. Valve Positions for Spraying Through the Bar.....	36
Figure 17. Valve Positions for Handspray.....	37
Figure 18. Valve Positions for Spray Bar Suck Back.....	38
Figure 19. Valve Positions for Flushing.....	42
Figure 20. Enviro-Flush Flow Diagram.....	44
Figure 21. Recirculating Flushing System Operation.....	45
Figure 22. Valve Positions for Unload with External Pump.....	46
Figure 23. Valve Positions for Unload with Distributor Pump.....	48
Figure 24. Valve Positions for Transfer.....	50
Figure 25. Manual Ignition Control System.....	53
Figure 26. Ignition & Out Fire Control System.....	54
Figure 27. Fuel Oil Burner System.....	58
Maintenance	
Figure 28. Gun Assembly.....	62
Figure 29. Right Hand / Left Hand Electrodes.....	62
Figure 30. Electrode Setting.....	62
Figure 31. Hydraulic Motor.....	63
Figure 32. Etnyre Asphalt Pump.....	64
Figure 33. Fluid Cleanliness Chart.....	67
Figure 34. Serial Number Plate Location.....	71

Warning And Instruction Plates

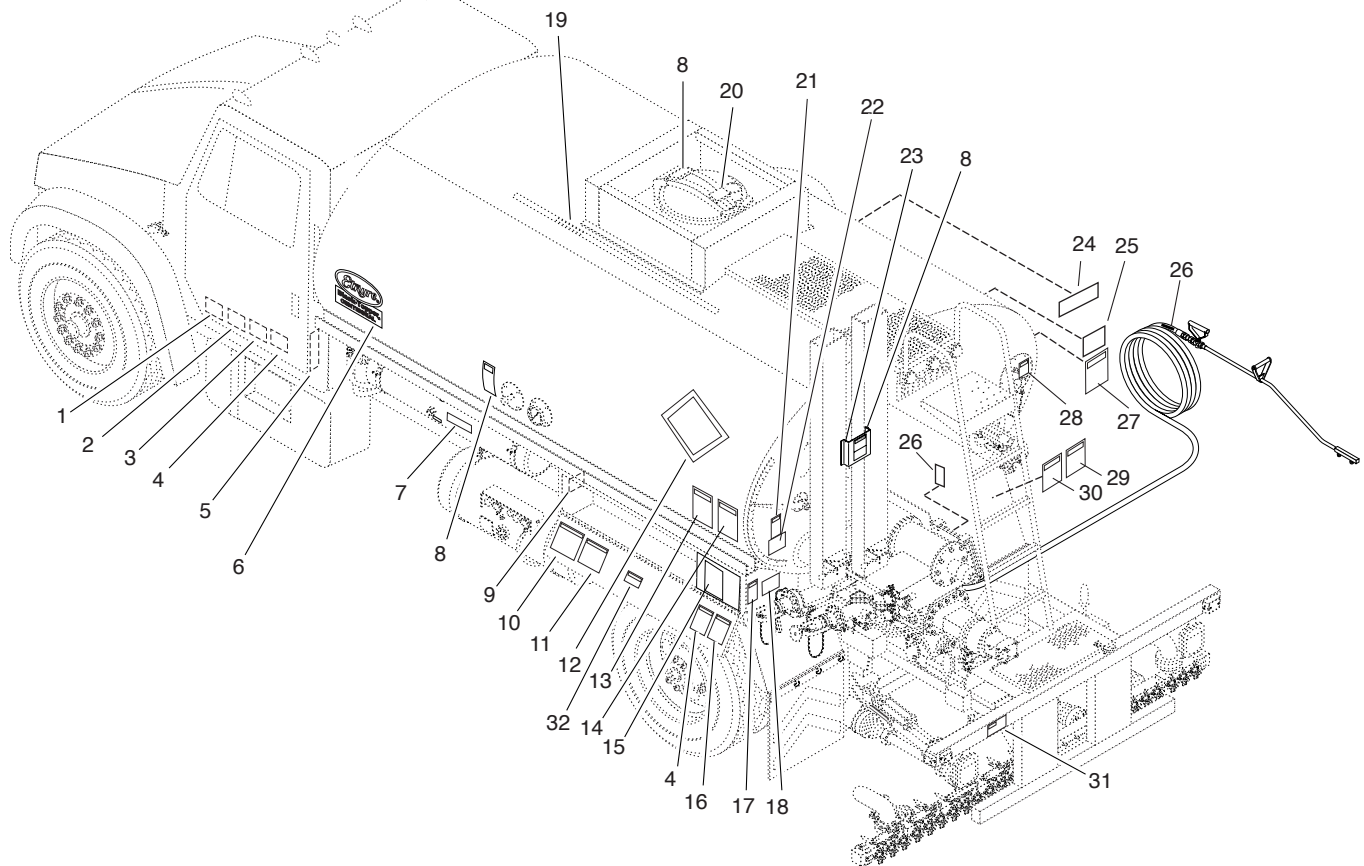

For operator safety and possible liability protection, all Safety and Instruction Plates should remain in place and be legible



Should a plate be removed, lost, or become illegible, reorder and replace immediately



If plates become difficult to read because of material coating the surface, clean with solvent

REF	PART NO.	QTY	DESCRIPTION	REF	PART NO.	QTY	DESCRIPTION
1	6320808**	1	Decal-Warn, Electrical Equipment	19	3390645	1	Label-Measuring Stick, 1 Flue
2	6320807**	1	Decal-Warn, Master Power		3390656	1	Label-Measuring Stick, 2 Flues
3	6320796**	1	Decal- Warning, Before Starting	20	6320794	2	Plate- Warning, Manhole
4	6320793**	2	Decal- Warning, Manuals	21	6320790 **	1	Decal-Warning, GVWR
5	3390597	1	Plate-Name, Spec, VIN	22	3390880	• 1	Decal-Handspray Operation
6	3390696	2	Decal, Blacktopper Centennial	23	3390562	1	Bracket- Mtg, Decal, Hot Surface
7	6320786**	1	Plate-Instr, Hydraulic Oil	24	6320800 **	1	Decal-Diesel Fuel Only
8	6320797**	3	Plate-Caution, Hot Surface	25	6320809 **	1	Decal-Instr, Air Oiler
9	3390655*	1	Plate-Name, Distributor S/N, Brass	26	6320785 **	2	Decal-Warn, 1" Handspray Hose
10	6320798**	1	Decal-Warning, Safety, General		6320806 **	2	Decal-Warn, 3/4" Handspray Hose
11	6320953	• 1	Decal-LP Burners	27	6320802 **	1	Decal-Warning, Handspray Hose
			or	28	6320784 **	1	Decal-Warning, Personal Protection
	6320954	• 1	Decal-LP Burners w/ Outfire	29	6320799 **	1	Plate- Warning, Burner, General
			or	30	6320787 *	AR	Decal- Directions, LPG Burner
	6320966	• 1	Decal-Fuel Oil Burners	31	6320804 **	1	Decal-Warning, No Riders
12	6320272	AR	Placard System (Optional)	32	6320792	AR	Decal- Directions, Fuel Oil Burners
13	6320789**	1	Decal- Warning, Asphalt Grades				*Included in 6320782 Decal Kit
14	6320795**	1	Decal- Warning, Fill Line Cap				•Included in 6320956 Decal Kit
15	6320788**	1	Decal-Lubrication Chart				starting with Serial# S5724
16	6320796**	1	Decal- Warning, Before Starting				
17	3390636	1	Decal- Warning, Flues Covered				
18	9320955	• 1	Decal-Spray Valve Lubrication (VWSB)				

AR = As required

Figure 1. Location of Warning and Instruction Plates



NOTICE

The handling of Cationic Emulsions (CRS-2, CMS-2, CSS-1 and CSS) may create an environment within the Asphalt Distributor that can be corrosive to carbon steel and cast iron.

- Cationic Emulsions are widely used within the industry.
- Cationic Emulsion is manufactured with asphalt, water, emulsifiers and hydrochloric acid. The chemistry of individual emulsions varies in asphalt content and Ph levels.
- Tanks and spray mechanisms used with Cationic emulsions may experience corrosion
- It is believed the chemistry of the emulsion - specifically the residual fumes promote the corrosion
- Etnyre Distributors are compatible with Cationic Emulsions provided that certain precautions are taken.
- Prior to placing a distributor in to service with Cationic Emulsion, it should be loaded with an AC or MC type material to develop a protective coating.
- Periodic inspection of the tank and spray system should be preformed in the normal course of operation.
- It is recommended that distributors used in Cationic service be flushed periodically and at the end of the season with an AC, MC or cutback to remove the corrosive materials and to provide a protective coating.
- Increasing the quantity of flushing material during daily suck back and cleanout operations will also help to minimize corrosion damage.
- Dilution is the solution.
- Additional information can be acquired from your Emulsion supplier as well as the Asphalt Institute or the Asphalt Emulsion Manufactures Association.



WARNING

Take extra care and follow recommended procedures when alternating asphalt materials especially when loading hot product, over 212 degrees Fahrenheit (100 degrees Celsius), on to a tank and system previously in Emulsion service.

General Safety Instructions

The operation of a bituminous distributor normally requires handling of liquid products at elevated temperature. Also, these liquids may be of a volatile nature. A heating system is supplied to raise or maintain the product temperature, and these systems use highly combustible fuels. As with any type of construction equipment, there are certain hazards associated with careless or improper operation.

Safety warnings have been provided to call attention to any potentially hazardous situation that may cause property damage, personal injury or death to the operator or bystanders. These safety warnings will be shown at various times throughout this manual, as they are applicable to the subject being presented. These safety warnings are identified by the following warning symbols:

Safety Precautions, Hazard Seriousness Level

You will find safety information boxes throughout this manual. These boxes contain information alerting you to situations or actions to avoid.

Signal words (DANGER, WARNING, and CAUTION) are used to identify levels of hazard seriousness. Their selection is based on the likely consequence of human interaction with a hazard. Definitions of hazard levels are as follows.



DANGER - Immediate hazards which will result in severe personal injury or death.



WARNING - Hazards or unsafe practices which could result in severe personal injury or death.



CAUTION - Hazards or unsafe practices which could result in minor personal injury or product or property damage.

All of these warnings are listed below and they also appear throughout the manual. In addition to these, you will find notes throughout the manual.

NOTE - A note provides general information that the operator should be aware of when performing an operation.



DANGER

To avoid an extreme fire hazard or explosion, NEVER use gasoline as fuel in diesel or fuel oil burners.



WARNING

A fully charged dry chemical type fire extinguisher must be within easy reach whenever the burners are operating or there is an open flame near the Distributor. The minimum capacity of the fire extinguisher should be 10 pounds.

Please Note This Warning and Remember:

- Always start and operate the engine in a well ventilated area.
- If in an enclosed area, vent the exhaust to the outside.
- Do not modify or tamper with the exhaust system.

WARNINGS



WARNING

A fully charged dry chemical type fire extinguisher must be within easy reach whenever the burners are operating or there is an open flame near the Distributor. The minimum capacity of the fire extinguisher should be 10 pounds.

Fluoroelastomer Handling

Some O-rings and seals used in this vehicle are made from fluoroelastomers. When used under design conditions, fluoroelastomers do not require special handling. However, when fluoroelastomers are heated to temperatures beyond their design temperature (around 600° Fahrenheit), decomposition may occur with the formation of hydrofluoric acid. Hydrofluoric acid can be extremely corrosive to human tissue if not handled properly.

A degraded seal may appear as a charred or black sticky mass. Do not touch either the seal or the surrounding equipment without wearing neoprene or PVC gloves if degradation is suspected. Wash parts and equipment with 10% lime water (calcium hydroxide solution) to neutralize any hydrofluoric acid.

If contact with the skin occurs, wash the affected areas immediately with water. Then rub a 2.5 calcium gluconate gel into the skin until there is no further irritation, while seeking prompt medical attention.

Note to Physicians: For advice or treatment of HF burns, call the DuPont Medical Emergency number, 1-800-441-3637.

To prevent an explosion or fire hazard:

- Position the unit broadside to the wind to prevent volatile fumes from drifting toward the burners.
- Do not operate the burners if the tank is damaged or leaking.
- Ensure that the burners are extinguished before removing any material from the tank in any manner. Liquid petroleum (LP) burners can support a flame for several minutes after the fuel supply is turned off.

To prevent an explosion or fire hazard:

- Do not operate the burners when the vehicle is unattended, when the vehicle is in motion, or with the vehicle in a confined area.
- When the burners go out, shut off the fuel supply to both burners and allow the flues to ventilate for at least 3 minutes before re-lighting the burners.
- Do not heat the material beyond the manufacturer's recommended temperature.
- Keep burning cigarettes or other sources of combustion away from manholes and overflow vents.
- Keep area free of all sources of combustion when spraying.
- Check the tank vent to insure that it is free from obstruction before lighting the burners.
- Eliminate sparks from engine exhaust.
- Do not operate the burners with the manhole open or open the manhole while the burners are in operation.
- Flues must be covered by a minimum 6 inches of material (bitumen) when burners are in operation.

To prevent possible hand or facial burns:

- Always light the inside burner first. Do not reach across a lit burner to light or re-light the inside burner. Shut off the outside burner before lighting the inside burner.

To prevent possible burns:

- Always use a torch to light the burners. Never attempt to light the burners using a match or pocket lighter.
- Always wear insulated gloves when handling spray bar sections or hoses.
- Always wear eye protection, face shield, long sleeve shirt, insulated gloves, boots, and long pants outside the boots when working around the Distributor.
- Use extreme caution when using a torch to heat the pump. Asphalt accumulated around the pump may ignite when heating the pump with a torch.



WARNINGS

To prevent possible burns from leaking material:

- Be sure all pipe, cap and hose connections are secure before opening valves, or beginning any operation.

To prevent possible burns from hot asphalt spray:

- Do not stand, or allow anyone to stand where accidental opening of a valve may cause contact with hot asphalt.

To prevent possible burns from foaming or violent eruption:

- Do not load tank with material temperature over 200°F if water or condensation is present in tank, or if emulsion was used in the previous load.
- Do not heat material over 200°F if moisture or emulsified material is present in tank.

To prevent burns from hot asphalt when hand spraying:

- Hold the handspray gun in proper position and watch for other people.

To prevent possible burns to operators or bystanders, or possible equipment damage:

- Do not start any operation if any control settings are unknown.

To prevent severe injury from becoming entangled in machinery:

- Stand clear of rotating drives.

To prevent possible injury:

- Always open the manhole cover slowly. Pressure build up in the tank may cause the cover to burst open.

To prevent possible fire hazards, burns or falls:

- Keep the unit clean for safe operation.

To prevent possible burns from material overflow:

- Allow sufficient space in the tank for expansion of the material when heating
- Before removing the fill line cap, make certain that the asphalt pump is turning and the tank valve is closed.



WARNING

To prevent possible personal injury:

- Do not load the vehicle beyond the GAWR or GVWR. The maximum load volume must be calculated based on material density.

Allowing the burners to operate for a long period of time without circulating can damage the product and create explosive fumes. If product cannot be circulated after fifteen minutes of heating without circulation, the burners should be extinguished for 20 - 30 minutes before re-lighting the burners.

WARNING

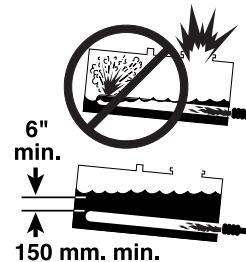

Do not light burners unless flues are covered. Explosion can occur causing death or serious injury.

Lower Burner

Lit. Gal.

Upper Burner

Lit. Gal.

3390636

WARNING

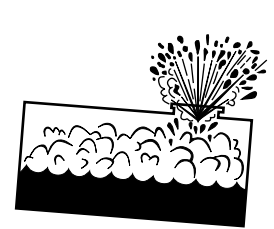

Do not change asphalt grades without reading operators manual. Explosion can occur causing death or serious injury.

3390637

Use the measuring stick as shown in **Figure 12** in the *Using the Measuring Stick* section to determine the amount of product in the tank before lighting burners. The minimum amounts shown on the warning placard only apply if the tank is level.

Remember that the measuring stick is accurate only when the tank is level. If the tank is not level, reposition the Distributor to place the tank in a level position before taking final measurement. You must have at least the amounts shown, with the tank level, in order to safely light the lower burner and upper burner respectively. **Failure to have the appropriate amount, accurately measured can result in an explosion causing death or serious injury.**

Foaming



WARNING

To prevent possible burns from foaming or violent eruption:

- Do not load tank with material temperature over 200°F if water or condensation is present in tank, or if emulsion was used in the previous load.
- Do not heat material over 200°F if moisture or emulsified material is present in tank.

If the Distributor is to be filled with hot bitumen, proceed very cautiously. If there is any moisture in the tank, or if an emulsion product was the last load, foaming or eruption may occur.

Dow-Corning DC-200 may be used to prevent foaming in Distributors, Transports, and Maintenance Units.

Mix the contents of one can (16 oz.) with one (1) gallon of diesel fuel or kerosene. Add one (1) oz. of this diluted mixture to each 1000 gallons of asphalt. The correct amount may be poured through the manhole. This will assist in reducing foaming, particularly if moisture is present or if an emulsified asphalt was used in a previous load.

If foaming does not occur at the start of the loading operation, but you suspect that there may be moisture in the spray bar or circulating system, the loading operation should be stopped when the tank is no more than 25% full. The product should then be circulated through the spray bar at a rate of 80 to 100 GPM before continuing the loading operation.

If foaming does occur, continue circulating until the foaming stops, and then suck back the product in the spray bar back into the tank before filling the tank the rest of the way.

Asphalt Institute

To further increase awareness of the hazards associated with the operation of a bituminous distributor, and before beginning initial operation, the operator should also receive instruction by an authorized Etnyre dealer, or Etnyre representative.

The Centennial Distributor is designed to handle a number of different products, such as ACs, cutbacks & emulsions.

Knowledge of these liquid asphalts is required for safe operation of the Distributor. It is critical to know which product can be loaded after the previous product, and which products react with each other.

The Asphalt Institute is a source of asphalt handling safety information.

Asphalt Institute
Research Park Drive
PO Box 140052
Lexington, KY 40512-4052
606-288-4960

Introduction

Your Etnyre Blacktopper Centennial Distributor is designed to give you many years of accurate, dependable, and economic service. The following instructions will enable you to receive the maximum performance from your Blacktopper Centennial Distributor.

The Blacktopper Centennial Distributor's controls are designed for simple operation. They require a minimum of training for proficient usage. The exclusive Etnyre circulating system is designed and built for handling all grades of bituminous materials efficiently.

This manual is provided as a tool to aid personnel in the operation of the Etnyre Blacktopper Centennial Distributor in a safe and efficient manner. As with any type of construction equipment, there are certain hazards associated with improper or careless operation. The ability to read and understand the instructions in this manual should be a required qualification to become an operator. There are also functions that require a certain amount of physical strength to accomplish. Persons lacking the required strength may not only place themselves in jeopardy, but also others in the vicinity.

This manual covers standard features and options for truck mounted units with computerized controllers only. If your unit is equipped with Basic Controls, please refer to Operation manual number M-102-99 or later. If your unit incorporates custom features, some of the information contained in this manual may not apply. If you have any questions regarding this manual or your unit, contact your Etnyre dealer or the E. D. Etnyre Service Department at 1-800-995-2116.

Reporting Safety Defects

If you believe that your vehicle has a defect which could cause a crash, or could cause injury or death, you should immediately inform the National Highway Traffic Safety Administration (NHTSA) in addition to notifying E. D. Etnyre & Co.

If NHTSA receives similar complaints, it may open an investigation; and, if it finds that a safety defect exists in a group of vehicles, it may order a recall and remedy campaign. However, NHTSA cannot become involved in individual problems between you, your dealer, or E. D. Etnyre & Co.

To contact NHTSA, you may either call the Auto Safety Hotline toll free at 1-800-424-9393 (or 336-0123 in the Washington, D.C. area) or write to NHTSA, U.S. Department of Transportation, Washington, DC, 20696. You can also obtain other information about motor vehicle safety from the hotline.



CAUTION

Unusually strong electromagnetic interference could cause the electronic controls on this equipment to temporarily malfunction. Test the effect of two way radios and similar equipment while operating in a safe area.

Component Location And Identification

Rear and Side Components

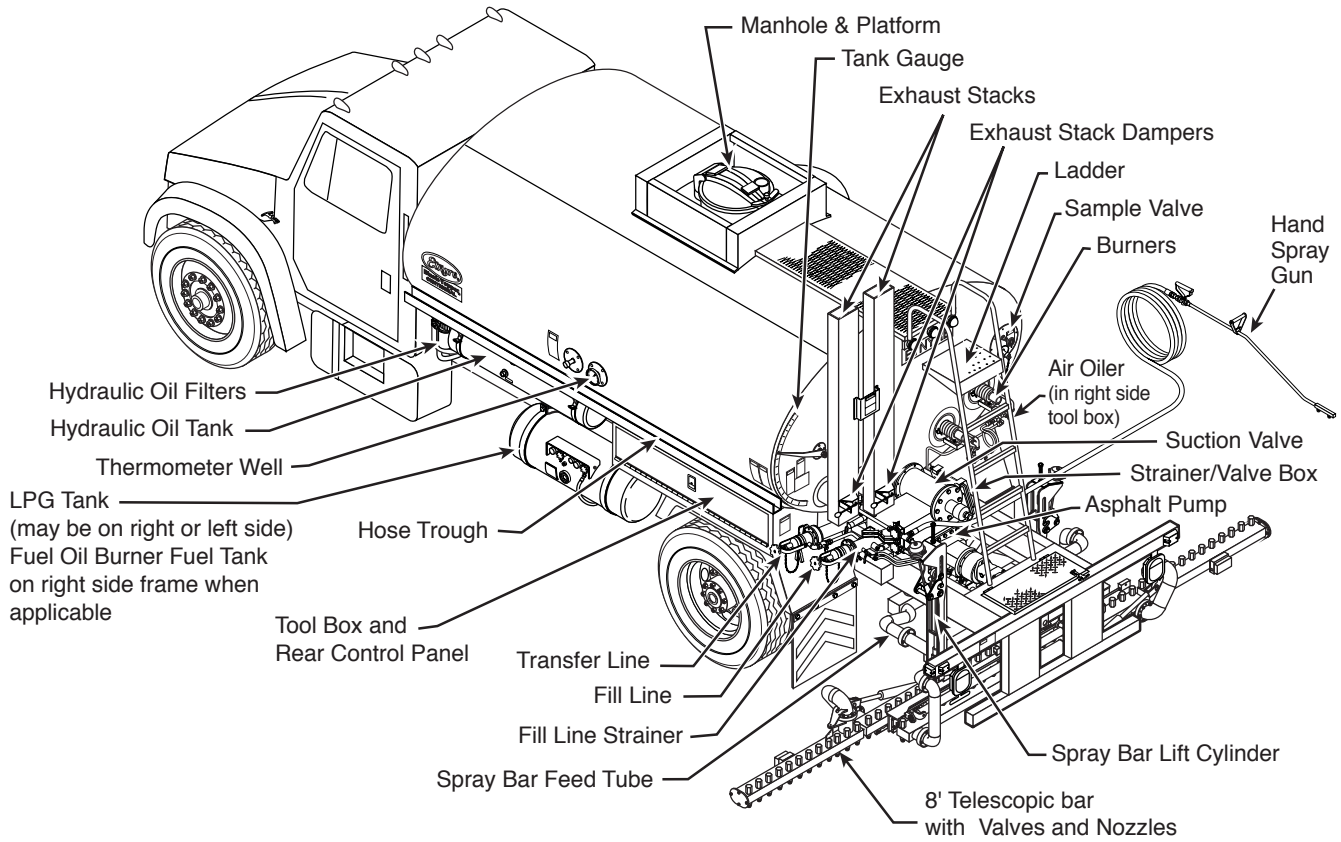

Figure 2. Rear and Side Component Identification

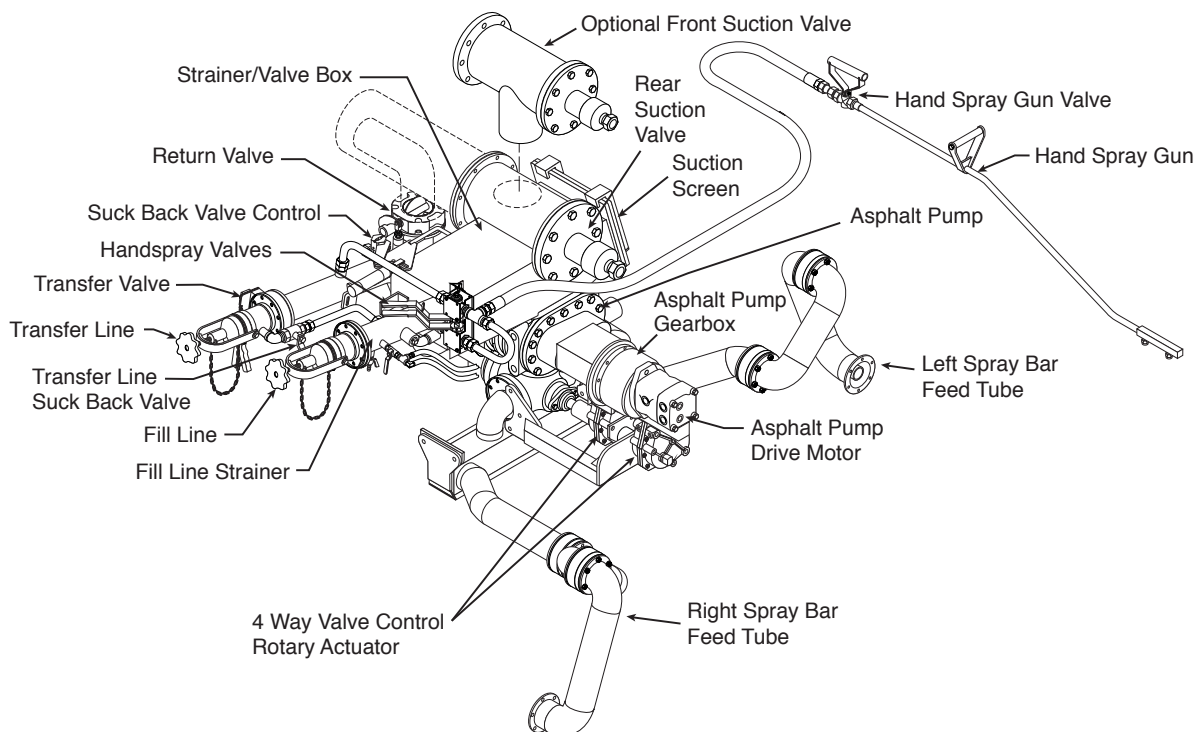

Figure 3. Rear Component Identification

Spray Bar Components

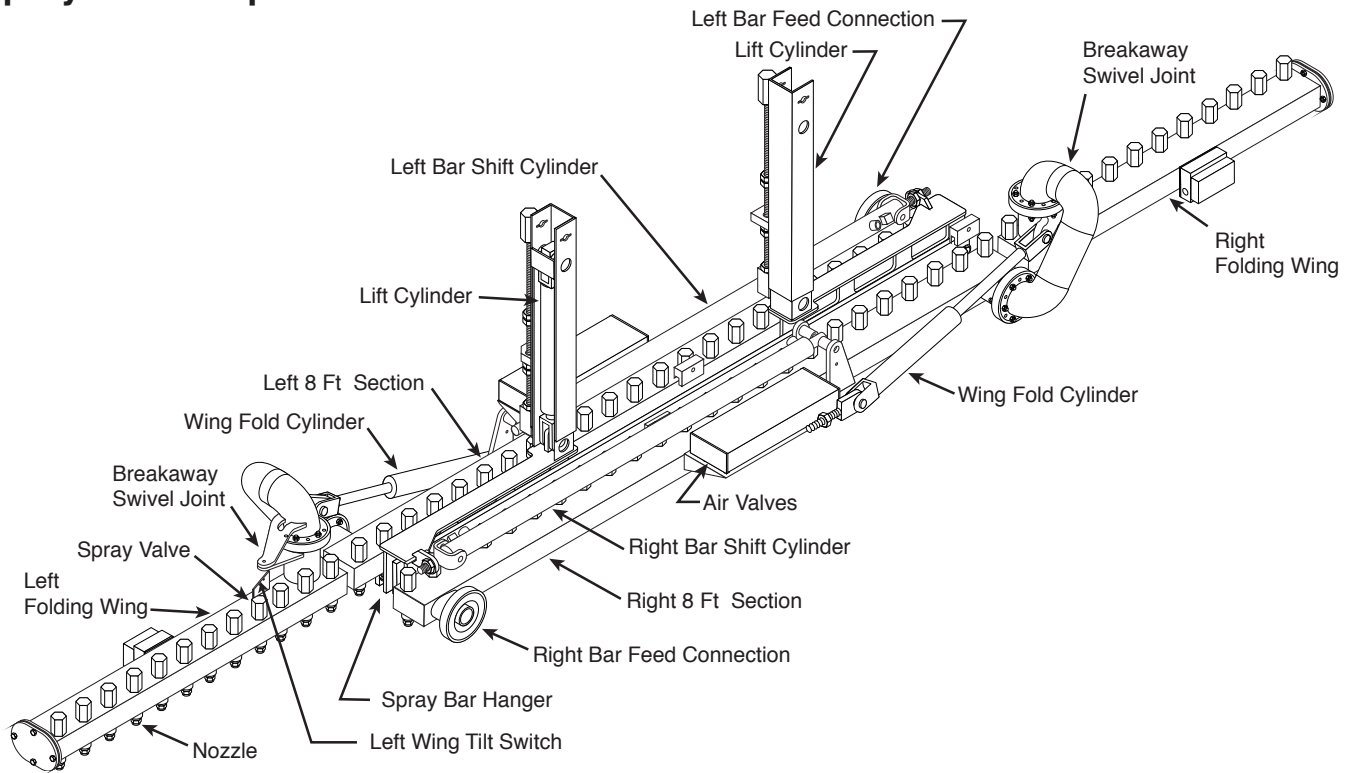

Figure 4. Spray Bar Component Identification

Hydraulic Tank Components

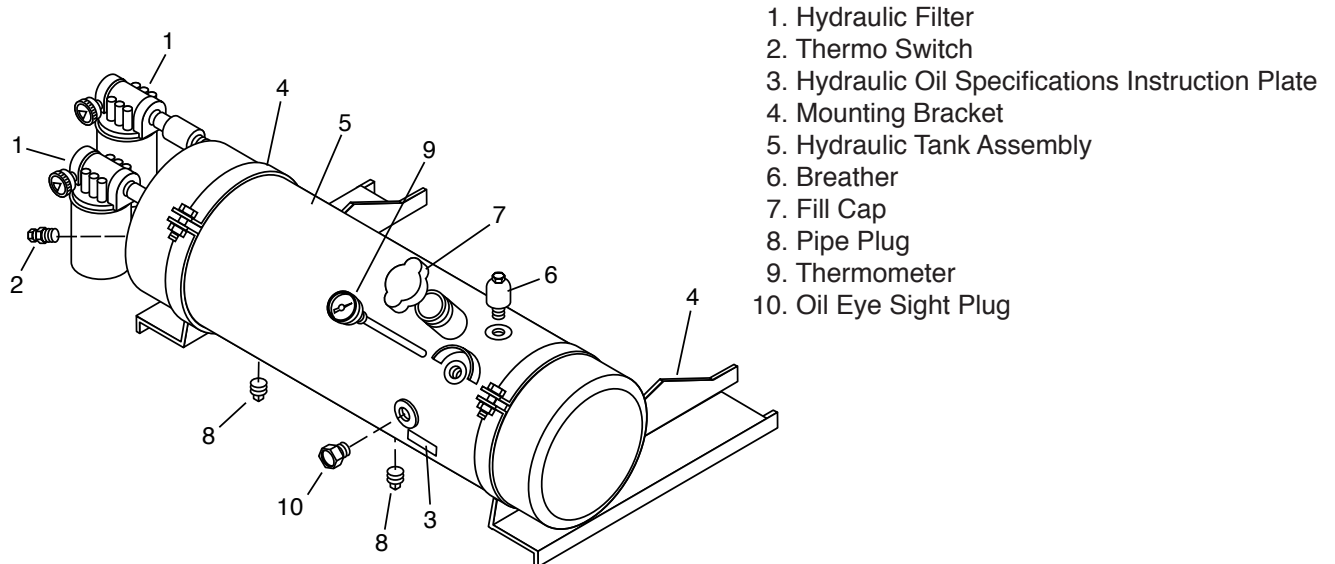

Figure 5. Hydraulic Tank Component Identification

Cab Control Panel

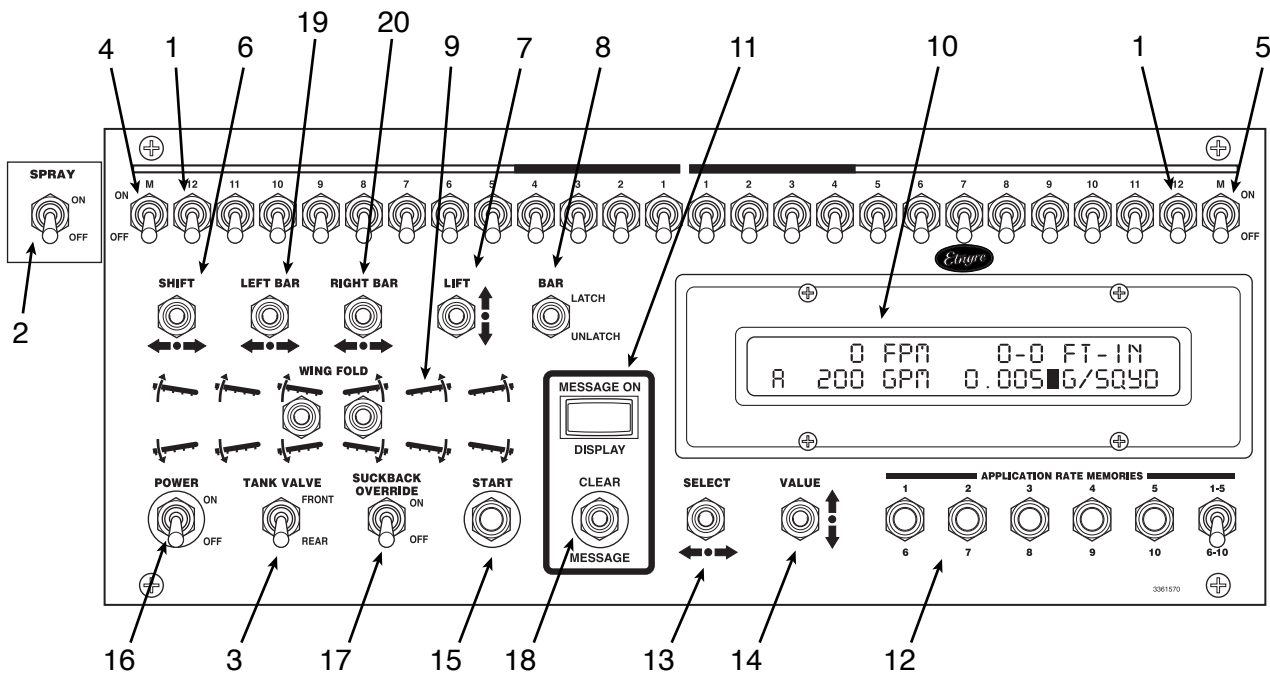

Figure 6. Cab Control Panel Components

Cab Control Panel Descriptions

1. One Foot Switches

These switches activate a corresponding foot of spray bar valves, there are three spray valves per foot of spray bar. Switch and spray valve numbering starts from the center of the Distributor and goes outward in each direction. One Foot switches that are on a wing, which is raised, do not add to the displayed spray width even if they are turned ON.

The activated, switch ON, foot of spray bar will come when the SPRAY switch is turned ON. The computer will automatically change the pumping rate as spray valves are turned on or off while spraying to compensate for the number of feet being sprayed.

On variable width spray bars the spray valves associated with switch 1 are only in the center of the Distributor when the spray bar is fully extended. From the fully retracted position, spray valves associated with switch 4 are the first to be turned ON, with switch 4 ON, as the spray bar is extended. One Foot switches that are in the retracted portion of a variable width spray bar do not add to the displayed spray width even if they are turned ON.

2. MASTER SPRAY Switch

Turning this switch to ON when the Function knob (rear panel) is turned to BAR CIRCULATE or SUCK BACK, opens all activated spray valves. The spray valves are allowed to open in SUCK BACK for troubleshooting. Turning the SPRAY switch ON in the LOAD or TANK CIRCULATE positions of the Function knob allows the accumulated values to increment for measuring.

3. TANK VALVE Switch

Selects between the standard REAR tank valve and the optional FRONT tank valve. FRONT should always be selected prior to spraying to eliminate air in the load line. FRONT can then be selected at anytime while spraying.

4. LEFT MARKER VALVE Switch (Optional)

Activates the left side marker valve.

5. RIGHT MARKER VALVE Switch (Optional)

Activates the right side marker valve.

6. SHIFT Switch

Moves the entire spray bar left or right. Holding the switch in either direction moves the spray bar continuously until the switch is released, or until full right or left is obtained.

7. LIFT Switch

The bar latching position is when the spray bar is completely centered and raised. Unlatch the spray bar before lowering it. The spray bar may need to be raised to allow the bar latching mechanism to move. The spray bar cannot be lowered beyond the height adjuster setting, which is set for a spray height of 12 inches at the factory. The height adjusters may be adjusted higher or lower for individual preference. Also see the *Adjusting Spray Bar Height* section.

8. BAR Latch Switch (Optional)

The bar latching mechanism will remain in the desired position even though the switch does not. The spray bar should be latched prior to transport and unlatched prior to lowering for spraying.

9. WING FOLD Switches

Spray bars have fixed center sections and folding wings on both sides. Spray bars that have the corresponding One Foot switches turned ON will increase the spray width when the wing is lowered and decrease the spray width when raised beyond the wing tilt switch setting. It is always a good practice to turn OFF the corresponding One Foot switches before raising the wing while spraying.

10. Display

All information critical for Distributor operation is displayed on this two-line LCD. When the system is turned ON, the installed software version is displayed for a few seconds, after which the first of the operating screens is displayed. Additional screens are used for setting up the computer. Information messages flash over the entire display to communicate critical information.

Refer to the *Setting up the Computer and Operation Screens* sections in this manual for more information.

11. MESSAGE Light

Indicates that there is critical information to be viewed on the Display.

12. MEMORY Switches

Store and recall up to ten preset application rates for quick selection. To store the desired application rate, make the application rate the selected value on the display then press and hold the desired Memory button while selecting the desired application rate with the VALUE switch. Each button has a factory preset between 0.050 and 0.500 G/SQYD, or the Metric equivalent. Memories 1-5 are available when the Memory expander switch is set to 1-5 and similarly, memories 6-10 are available when the Memory expander switch is set to 6-10.

13. SELECT Switch

Navigate through the display using the SELECT switch. The selected position on the screen is identified by the black box. The display reads like a book, right moves right and down while left moves left and up.

14. VALUE Switch

The selected value, identified by the black box, can be changed using this switch. Most values can be increased or decreased by holding the switch in the desired direction for large changes. The accumulated values on the second operating screen can be reset to zero by first selecting the desired value and then selecting VALUE decrease. Length and area reset together when area is selected prior to selecting VALUE decrease.

15. START Button

Starts the asphalt pump turning at the target pump rate, used also for calibration operations in the setup screens. When the Function knob (rear panel) is turned to BAR CIRCULATE, the displayed spray width must be greater than zero for the pump to start turning when the START button is pressed.

16. Power Switch

Both the POWER switch in the cab and the EMERGENCY STOP switch at the rear must be ON for the control system to be ON. The entire system can be shut down by turning either switch to OFF. Before turning either switch ON be sure you know what will automatically activate.

17. SUCK BACK OVERRIDE Switch

When ON, this switch overrides the current setting of the Function knob in the rear panel to the SUCK BACK selection. The SUCK BACK OVERRIDE must be OFF for the Function knob and the PUMP CONTROL switch to work correctly.

18. CLEAR MESSAGE button

After viewing the current information message(s) on the display selecting CLEAR MESSAGE will stop the message(s) from being displayed. A new message or selecting a different position on the Function switch will again allow all current information messages to be displayed. The MESSAGE ON DISPLAY light will remain ON as long as there are messages to be viewed.

19. LEFT BAR Switch

Extends or retracts the left variable width spray bar. Holding the switch in either direction moves the spray bar continuously until the switch is released or until the spray bar is fully extended or retracted. A single press of the switch in either direction moves the spray bar 4 inches until it is fully extend or retracted. If the spray bar, due to shifting, does not fully extend or retract, holding the switch in the desired direction for 5 seconds forces the spray bar

into position.

20. RIGHT BAR Switch

Extends or retracts the right variable width spray bar. Holding the switch in either direction moves the spray bar continuously until the switch is released or until the spray bar is fully extended or retracted. A single press of the switch in either direction moves the spray bar 4 inches until it is fully extend or retracted. If the spray bar, due to shifting, does not fully extend or retract, holding the switch in the desired direction for 5 seconds forces the spray bar into position.

Components Not Shown

The following components are not on the Cab Control Panel but may be mounted below the panel or on the vehicle's dash. Such as hour meter, mirror switch(s), beacon, strobe, PTO light.

Rear Control Panel

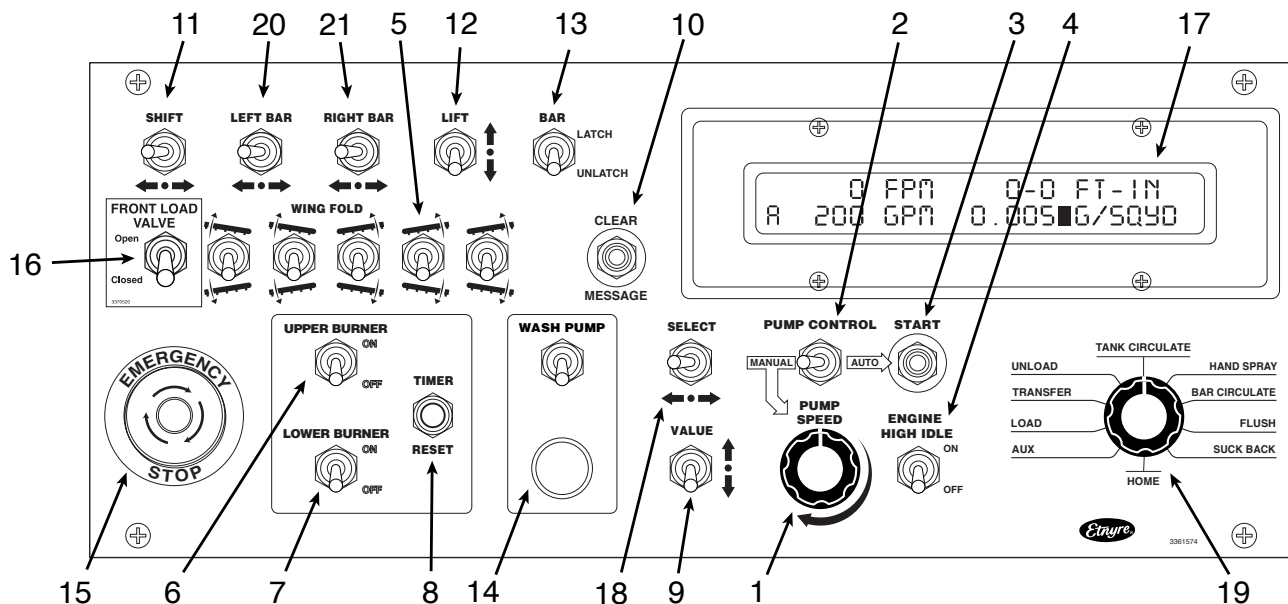

Figure 7. Rear Control Panel Components

Rear Control Panel Descriptions

1. PUMP SPEED Control Knob

When MANUAL PUMP CONTROL is selected, turning this knob to the right (clockwise) increases the asphalt pump speed. It is possible to over-speed the asphalt pump in MANUAL control since the asphalt pump speed is also dependent on the engine speed. Always turn the knob back to the left (counter-clockwise) before selecting AUTO PUMP CONTROL or turning ON the power switch in the cab or the Emergency Stop switch in the rear panel.

2. PUMP CONTROL Switch

With the switch turned to AUTO, the asphalt pump speed is controlled at the desired rate through the computer which limits the maximum pump speed to 450 GPM. When the Function knob is set to BAR CIRCULATE, the pump speed is limited to a maximum of 120 GPM. With the switch turned to MANUAL, the asphalt pump speed is controlled with the PUMP SPEED control knob.

In AUTO control, **A** flashes until the START button is pressed. In MANUAL control, **M** flashes until the START button is pressed. Use Etnyre computator (p/n 3390408) when spraying in MANUAL control.

3. START Button

Starts the asphalt pump turning at the target pump rate, and also for calibration operations in the setup screens. When the Function knob is turned to BAR CIRCULATE, the displayed spray width must be greater than zero for the pump to start turning when the START button is pressed.

4. ENGINE HIGH IDLE Switch

When this option is available and installed, turning ON this switch makes the engine run at a higher RPM. Turning OFF the switch resumes the engine speed to idle. The high idle setting varies but can be programmed to your preference through your truck dealer. This switch is not disabled through turning OFF power to the controls.

5. Wing Fold Switches

Spray bars have fixed center sections and folding wings on both right and left sides. Spray bars that have the corresponding One Foot switches turned ON will increase the spray width when the wing is lowered and decrease the spray width when raised beyond the wing tilt switch setting. It is always a good practice to turn OFF the corresponding One Foot switches before raising the wing while spraying. The Bifold and Trifold wings do not automatically adjust the displayed bar length when raised or lowered when the corresponding One Foot switches are On.

6. UPPER BURNER Switch

When any burner, fuel oil or LP, with outfire control is installed, this switch directly controls the upper burner unless optional thermostatic control is also installed. Then it is possible for the switch to be ON when the burner is off. Before operating the burner, refer to the *Burner Operation* section in this manual.

7. LOWER BURNER Switch

When any burner, fuel oil or LP, with outfire control is installed, this switch directly controls the lower burner unless optional thermostatic control is also installed. Then it is possible for the switch to be ON when the burner is off.

Before operating the burner, refer to the *Burner Operation* section in this manual.

8. Timer Reset Switch

When the optional burner controls are installed, selecting this switch when the burners are operating will extend the heating time.

9. VALUE Switch

(Included with optional Display)

The selected value, identified by the black box, can be changed using this switch. Most values can be increased or decreased by holding the switch in the desired direction for large changes. The accumulated values on the second operating screen can be reset to zero by first selecting the desired value and then selecting VALUE decrease. Length and area reset together when area is selected prior to selecting VALUE decrease.

10. CLEAR MESSAGE button

(Included with optional Display)

After viewing the current information message(s) on the display selecting CLEAR MESSAGE will stop the message(s) from being displayed. A new message or selecting a different position on the Function switch will again allow all current information messages to be displayed. The MESSAGE ON DISPLAY light will remain ON as long as there are messages to be viewed.

11. SHIFT Switch

Moves the entire spray bar left or right. Holding the switch in either direction moves the spray bar continuously until the switch is released, or until full right or left is obtained.

12. LIFT Switch

The bar latching position is when the spray bar is completely centered and raised. Unlatch the spray bar before lowering it. The spray bar may need to be raised to allow the bar latching mechanism to move. The spray bar cannot be lowered beyond the height adjuster setting, which is set for a spray height of 12 inches at the factory. The height adjusters may be adjusted higher or lower for individual preference. Also see the *Adjusting Spray Bar Height* section.

13. BAR Latch Switch (Optional)

The bar latching mechanism will remain in the desired position even though the switch does not. The spray bar should be latched prior to transport and unlatched prior to lowering for spraying.

14. WASH PUMP Switch and Light

When the optional solvent pump and switch is installed turning the switch ON will allow use of the solvent wash wand or application of solvent to the top of the asphalt pump without the pump turning. The light is a reminder that the switch and pump are ON.

15. EMERGENCY STOP Switch

Both the POWER switch in the cab and the EMERGENCY STOP switch at the rear must be ON for the control system to be ON. The entire system can be shut down by turning either switch to OFF. Before turning either switch ON be sure you know what will automatically activate. The EMERGENCY STOP switch is turned OFF by pushing in and turned ON by rotating counter clockwise.

16. FRONT LOAD Switch (Optional)

When the optional front load switch is installed, selecting Open when in the Load or Transfer positions of the Function knob will open the front load valve. The Closed position allows the use of the standard load line.

17. Display (Optional)

All information critical for Distributor operation is displayed on this two-line LCD. When the system is turned ON, the installed software version is displayed for a few seconds, after which the first of the operating screens is displayed. Additional screens are used for setting up the computer. Information messages flash over the entire display to communicate critical information.

18. SELECT Switch

(Included with optional Display)

Navigate through the display using the SELECT switch. The selected position on the screen is identified by the black box. The display reads like a book, right moves right and down while left moves left and up.

19. Function Knob

When the desired operation is selected through this knob, all automatic valves (tank valve, 4-way valve, bar suck back valves, return valve and balance valves) are set for the desired operation,

and the asphalt pump stops and when the PUMP CONTROL is in AUTO the stored asphalt pump rate target preset for the desired operation is recalled. Changing the selection after the pump is turning will stop the asphalt pump in AUTO or MANUAL control. When BAR CIRCULATE is selected, the asphalt pump rate target is calculated based on the displayed spray width, application rate, and the setting of the %CIRC factor. For all positions of this switch, except BAR CIRCULATE, the asphalt pump rate preset can be set to operator preference by first selecting AUTO PUMP CONTROL. Then before pressing the START button, change the pump rate target to the desired rate and then press the START button to save the desired rate and start the pump turning.

The factory pump rate target presets are (With Metric equivalents also):

- LOAD 100 GPM
- TANK CIRCULATE 150 GPM
- SUCK BACK 200 GPM
- FLUSH 100 GPM
- UNLOAD 100 GPM
- HAND SPRAY and AUX 50 GPM
- TRANSFER 100 GPM
- HOME 0 GPM

20. LEFT BAR Switch

Extends or retracts the left variable width spray bar. Holding the switch in either direction moves the spray bar continuously until the switch is released or until the spray bar is fully extended or retracted. A single press of the switch in either direction moves the spray bar 4 inches until it is fully extend or retracted. If the spray bar, due to shifting, does not fully extend or retract, holding the switch in the desired direction for 5 seconds forces the spray bar into position.

21. RIGHT BAR Switch

Extends or retracts the right variable width spray bar. Holding the switch in either direction moves the spray bar continuously until the switch is released or until the spray bar is fully extended or retracted. A single press of the switch in either direction moves the spray bar 4 inches until it is fully extend or retracted. If the spray bar, due to shifting, does not fully extend or retract, holding the switch in the desired direction for 5 seconds forces the spray bar into position.

Preparing for Operation

NOTE: Always refer to the truck chassis owner's manual for chassis and engine maintenance information.

The following procedures apply to new or rebuilt units.

1. Inspect the unit for damage that may have occurred during transporting.
2. Check and tighten all fasteners, body tie-down bolts, pipe and circulating line connections, etc. that may have loosened in transit.
3. Check the fluid level in the hydraulic reservoir. The fluid must always be visible in the sight glass.



WARNING

To prevent possible personal injury, do not load the vehicle beyond the GAWR or GVWR. The maximum load volume must be calculated based on material density.

Setting Up the Computer

Before the Distributor is used, the control computer has to be set for each particular Distributor. The setup screens are used to set parameters and perform calibrations for the Distributor that the control computer is installed in. Setup is performed for the customer at the factory and should not need to be changed except for when major service or repair is performed on the Distributor.

To enter the set up screens hold Memory 6 and 10 buttons down while turning the POWER switch to ON. Then release the buttons. To exit the setup, turn the power OFF. Any changes that are made while in the setup screens are automatically saved.

The SELECT switch is used to navigate through the Setup screens, while the VALUE switch is used to change the value that is selected. The START switch is used to initiate calibration procedures in the Setup screens. Abbreviated instructions for the calibration procedures are displayed for quick recall.

First Screen

```
UNITS = ■ ENGLISH  
BAR CONTROL = FOOT
```

This screen allows you to set the display units and bar control. VALUE increase from English to

get Metric. SELECT switch to the right to enter Bar Control. **For Version 4.5 thru 4.6:** VALUE decrease from FOOT to get GANG or decrease from FOOT to get VW (variable width). Additional setup screens, for the calibration of VW spray bars, will become present if VW is selected for bar control. **For Version 4.7 & Up:** VALUE decrease from FOOT to get GANG. VALUE increase once from FOOT to get VW-SMNC (Smart Cylinder Non-Contact). VALUE increase twice from FOOT to get VW-SMC (Smart Cylinder Contact). VALUE increase 3 times gets to VW-PROX, which is for engineering only-do not use.

Second Screen

```
SPRAY DELAY ON = ■ 0.00  
SPRAY DELAY OFF = 0.00
```

This screen allows the setting of the Spray Delay On and Off times. The Spray Delay On is the amount of time, in seconds, after the Master Spray switch is turned on that the spray bar valves will be turned on. The Spray Delay Off is the amount of time, in seconds, after the Master Spray switch is turned off that the spray bar valves will be turned off. These delays allow time for the 4-way valve to turn before open and closing the spray bar. Physical delays within the mechanical controls of these valves may have significantly changed and should be addressed before making significant deviations from 0.20 seconds.

Third Screen

```
MOTOR PUL/REV = ■ 43  
FLOW FACTOR = 1000
```

This screen allows for selection of the hydraulic motor speed sensor pulses per revolution. The correct setting is dependent upon displacement. Holding the VALUE switch will not continuously increment or decrement the value. Two values are currently valid for the motor: 43 for 1.53 cubic inches per revolution (CIR) motor, and 46 for both 2.1 and 2.69 CIR motors.

This screen is used to set the flow factor. The flow factor is the calibration factor for the asphalt pump. Changing the value from 1000 (100%) does not

change the pump flow but does change the displayed pump rate. Values greater than 1000 increase the displayed pump rate while values less than 1000 decrease the displayed pump rate. The flow factor increments or decrements by 0.1% and should only be changed when you are absolutely sure that such a correction needs to be made.

Fourth Screen

```
THRESHOLD MA = 15.0
SUF TIME = 1.00
```

This screen allows for setting the hydraulic pump EDC threshold in milliamps. The threshold is the minimum required electrical current for the asphalt pump to turn. The threshold is optimally determined at a hydraulic pump speed of 1200 RPM. Threshold settings lower than actual produce instability in the pump control while settings higher than actual do not allow the asphalt pump to be controlled at the lowest speed possible.

This screen also allows the setting of the Start Up Factor (SUF) Time, in seconds. The SUF Time is the amount of time that the %SUF parameter, in the operating screens, adjusts the pump speed immediately after the SPRAY switch is turned ON.

Fifth Screen

```
GROUND SPEED CALIBRATION
START AT 300FT BEGIN
```

This screen allows for ground speed calibration. The ground speed is calibrated at the factory through the proper angle and height settings of the radar. Ground speeds that are displayed when the Distributor is parked are most likely due to engine vibrations through the truck frame or reflections off surfaces, such as water. Standing water present while spraying may give incorrect ground speeds. The instructions for calibration are abbreviated on the display.

First mark out a smooth, dry, flat, straight 300 foot path. While driving the Distributor at a constant speed of approximately 300 FPM press START when a fixed point on the truck crosses the first line. Then press the START button again when the same fixed point on the truck crosses the second line. Once the START button is pressed the first time, **BEGIN** on the screen changes to **END** and will change back to **BEGIN** when pressed the second time.

Sixth Screen

```
RESET ALL DEFAULTS
INCREASE VALUE
```

This screen provides the ability to reset parameters in the computer back to their default values. You should record all of your settings before proceeding. Resetting the parameters will clear all changes to the setup and operating parameters and including all calibrations.

Seventh Screen

```
VWVB LEFT FDBK = 0
START - FULL RET/EXT BAR
```

This screen allows for calibration of the left VW spray bar. The instructions for calibration are abbreviated on the display. Press START, extend the left spray bar completely, and retract the left spray bar completely. The feedback number on the display should increase as the spray bar extends and decreases as the spray bar retracts. When fully extended the feedback value should be 99 or 100, after which the fully retracted value should be 0. Recalibration from the factory calibration should not be required except when the smart cylinder or wiring to the smart cylinder has been replaced.

Eighth Screen

```
VWVB RIGHT FDBK = 0
START - FULL RET/EXT BAR
```

This screen allows for calibration of the right VW spray bar on. The instructions for calibration are abbreviated on the display. Press START, extend the right spray bar completely, and retract the right spray bar completely. The feedback number on the display should increase as the spray bar extends and decreases as the spray bar retracts. When fully extended the feedback value should be 99 or 100, after which the fully retracted value should be 0. Recalibration from the factory calibration should not be required except when the smart cylinder or wiring to the smart cylinder has been replaced.

Engaging Pump on PTO Equipped Distributors

Start the truck engine. Then, follow one of the procedures below.

Ensure that the truck parking brake is engaged before leaving the cab.

Manual Transmissions

Depress the clutch and pull outward or upward on the PTO control knob. Slowly let the clutch up. If the PTO fails to engage, depress the clutch pedal and pull up on the PTO handle until engagement occurs. Or, depress the electric air shift PTO switch if your vehicle is so equipped. Increase the engine rpm to a fast idle.

Automatic Transmissions

Push down on the foot brake pedal, move the gear selector to any forward gear and do one of the following.

- Pull upward or outward on the PTO control knob.
- Press the switch activated PTO switch.
- Press the electric air shift PTO switch if your vehicle is so equipped. When the PTO engages, move the gear selector to neutral. If the PTO fails to engage, release the brake pedal slightly while pressing the PTO switch, allowing the truck to inch forward until the PTO engages. Then move the gear selector back to neutral.



WARNING

To prevent an explosion or fire hazard, do not heat the material beyond the manufacturer's recommended temperature.



WARNING

To prevent possible burns to operators or bystanders, or possible equipment damage, do not start any operation if any control settings are unknown.



WARNING

To prevent severe injury from becoming entangled in machinery, stand clear of rotating drives.



CAUTION

To prevent possible damage to equipment from material setting up in hose or Distributor, ensure that bitumen in supply tank is heated sufficiently.

Spraying Operations

A correct spray pattern cannot be obtained unless the product is heated to its proper spraying temperature. Cold product will not provide sharp spray edges, and will cause streaking. If heating of the product is required, refer to the section of this manual on *Heating Product in Distributors* for instruction on operation of your particular type of burners.

The computer automatically adjusts the asphalt pump speed to deliver the correct amount of asphalt for the application rate, spray width and vehicle speed. The circulation rate in the bar when not spraying should be set to 50% of the pump speed while spraying. This circulation rate will allow the asphalt pump to reach the desired speed quickly when spraying is started. Circulation rates higher than 50% will result in a heavier start while rates below 50% will produce a lighter start.

Spray bar nozzles have a limited flow range at which optimal performance will be achieved. Flow rates greater than this optimal range will cause excessive overspray. Rates that are too low will cause the fan to sag and cause heavy edges. Refer to the nozzle selection chart in the operator's manual to select the nozzles appropriate for your conditions.

WARNING

To prevent an explosion or fire hazard, ensure that the burners are extinguished before removing any material from the tank in any manner. Liquid petroleum (LP) burners can support a flame for several minutes after the fuel supply is turned off.

WARNING

To prevent an explosion, do not operate the burners when the vehicle is unattended, when the vehicle is in motion, or with the vehicle in a confined area.

WARNING

To prevent an explosion or fire hazard, when the burners go out, shut off the fuel supply to both burners and allow the flues to ventilate for at least 3 minutes before re-lighting the burners.

WARNING

To prevent an explosion or fire hazard, do not heat the material beyond the manufacturer's recommended temperature.

WARNING

To prevent an explosion or fire hazard, keep burning cigarettes or other sources of combustion away from manholes and overflow vents.

WARNING

To prevent possible hand or facial burns, always light the inside burner first. Do not reach across a lit burner to light or re-light the inside burner. Shut off the outside burner before lighting the inside burner.

WARNING

To prevent possible burns from material overflow, allow sufficient space in the tank for expansion of the material when heating.

WARNING

To prevent possible burns to operators or bystanders, or possible equipment damage, do not start any operation if any control settings are unknown.

WARNING

To prevent possible burns from leaking material, be sure all pipe, cap and hose connections are secure before opening valves.

WARNING

To prevent possible burns from hot asphalt spray, do not stand, or allow anyone to stand where accidental opening of a valve may cause contact with hot asphalt.

Setting the Digital Memory Presets

Setting the digital memory presets is not required to spray. The memory buttons offer the operator a convenient way to store different preset application rates. These settings are saved in the memory even after the power switch has been shut off.

To store an application rate in a memory location, select GAL/SQ YD in the digital display using the SELECT switch.

To set a memory, push that preset button in and hold it. While holding it in, set the application rate to the desired value using the VALUE switch. To raise the application rate hold the VALUE switch up and to lower the application rate, hold the VALUE switch down. When you have the application rate set to the desired value, release the memory button. The displayed application rate will be stored in that memory location until it is over-written with a new application rate using the same procedure.

Adjusting the Spray Bar Nozzle Angle

Adjust the nozzles to obtain an angle of approximately 30 degrees with the spraybar center line. Every nozzle should be at the same angle. A nozzle adjustment wrench is supplied with each new unit.

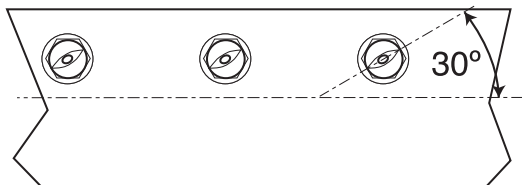

Figure 8. Adjusting the Spray Bar Nozzles

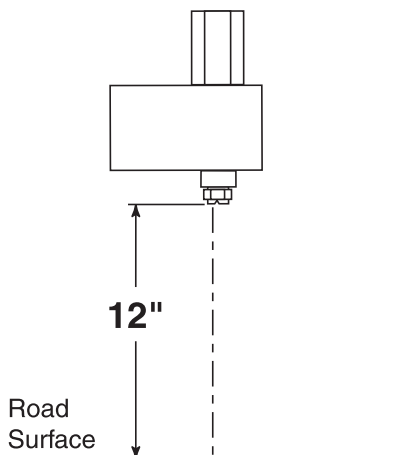

Figure 9. Adjusting the Spray Bar Height

Adjusting the Spray Bar Height

Lower the spraybar and adjust the height adjusters so that the nozzles are approximately 12 inches above the road, on the main bar with both wings folded, when the tank is empty. At this height, the spray fans from the nozzles will overlap to provide triple lap coverage of material on the ground. This is the normal spraying height. Lower the wings and adjust them with the cylinder nuts to follow the crown of the road.

Spraying Through the Bar

A tack coat selector valve on the air oiler assembly allows you to select between truck pressure and 20 psi. The lower regulator should be set to 20 psi. When Tack Coat is selected, the top side of every other spray valve has truck pressure applied, which overcomes the truck pressure applied to the underside of the spray valve because of the difference in areas and the additional spring on the top side. In Normal Spray, all spray valves have 20 psi on the top side. Be sure that this valve is selected correctly before continuing.

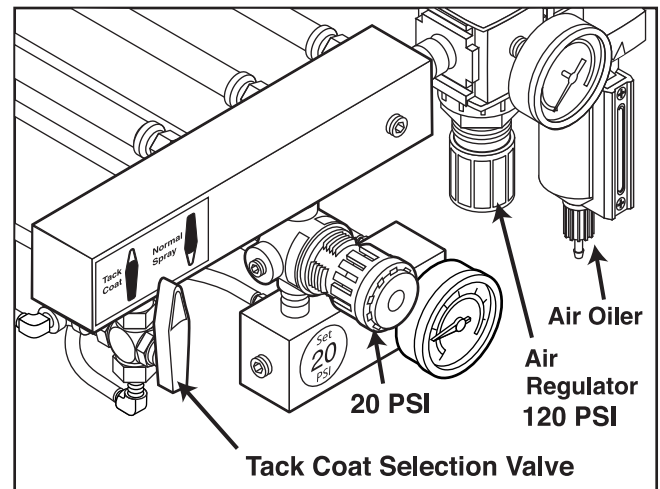

Figure 10. Selector Valve set to Normal Spraying

If you are stopped and shut the spray bar off, the computer will shut the spray bar off within a few seconds so that asphalt doesn't puddle, but you will not get a straight line.

Operation

Tank Capacity

The Centennial Distributor is designed to pump and spray a variety of asphalt products in an efficient and user friendly manner with great accuracy. The Centennial Distributor utilizes a computer to sense the vehicle's ground speed and control the hydrostatically driven asphalt pump to maintain the set application rate, regardless of variations in vehicle speed or spray bar width in use.

For a complete description of each of the controls and how to set up the machine, refer to the *Preparing for Operation* section of this manual.



WARNING

To prevent possible personal injury, do not load the vehicle beyond the GAWR or GVWR. The maximum load volume must be calculated based on material density.

The Centennial Distributor tank has a built-in air space, or expansion space, above the *Tank Full* level. This air space is designed to minimize the chance that the tank will overflow if the material in the tank expands due to heating or foaming. This air space should not be used to carry product. The *Tank Full* level is based on the vehicle's axle ratings, and, GVWR at a material density of 7.7 lbs/gallon. A lower *tank full* must be calculated if a product with a density greater than 7.7 lbs/gallon is to be loaded. The lower *tank full* is calculated by multiplying the original *tank full* by 7.7 and dividing the result by the new heavier product density.

If you suspect there may be moisture or emulsion in the tank, Dow-Corning DC-200 additive can be used to reduce foaming if a product being pumped is at a temperature in excess of 200°F. Additional DC-200 additive may be obtained from E. D. Etnyre & Co. or your Etnyre dealer.

Operation Screens

The following screens on the Cab Control Panel are used during normal operation. Use the SELECT switch to scroll through the values and screens and the VALUE switch to increase or decrease the selected value, when appropriate.

When the system is turned ON the installed software version is displayed for a few seconds, after which the first operating screen is displayed.

```
ETNYRE  
VERSION 4.5
```

First Operating Screen

```
0 FPM    0-0 FT-IN  
A 200 GPM 0.005 ■ G/SQYD
```

The first operating screen displays ground speed, spray width, asphalt pump speed, and application rate. The application rate is automatically the first selected value and is identified as the selected value with the black box. **A** or **M** will also flash in front of the pump rate. When PUMP CONTROL is in AUTO, **A** will stop flashing after pushing the START button. When PUMP CONTROL is in MANUAL, **M** will stop flashing after pushing the START button. Spray width is only selectable in gang bar control. Ground speed is never selectable and the pump speed is not selectable in manual pump control, bar circulate, or when spraying.

Second Operating Screen

```
0 ■ SQYD    0 GAL  
0 FT      100 F / 95 TGT
```

The second operating screen displays the square yards, gallons sprayed and distance in feet traveled as well as the asphalt tank temperature and target temperature for burner control. The accumulated values can be used for recording shots or the area and distance can be used for dry measuring. The accumulated values will exceed the displayed values after 999,999. The temperature is displayed as 999 when the RTD is not connected to the computer.

Third Operating Screen

75%SUF 50 %CIRC
5 MIN GPM

The third operating screen allows for quick set up of the start-up factor, bar circulation rate factor, and minimum pump speed. The start up factor changes the pump speed for the first half-second of spraying. 100 %SUF makes no change. Higher start-up factors increase the pump speed while lower start up factors decrease the pump speed. In BAR CIRCULATE, the asphalt pump rate target is calculated based on the displayed spray width, application rate, and the setting of the %CIRC factor. A setting of 50% is recommended and is equivalent to half the pump speed required when traveling at a speed of 150 FPM while spraying. The minimum pump speed is used in bar circulate and spray. In either operation, when all of the One Foot switches are turned OFF, the minimum pump speed is not used and the pump speed goes to zero.

Information Messages

Messages will be displayed only in the main operating screens and will alternate or flash between the message and the current operating screen. If more than one message is active, each of the active messages will be sent to the display before an individual message is repeated to the display.

Additional messages will become present if VW is selected for bar control in the setup screens. VW bar control should not be selected for units with FOOT bar control.

Application Pump

UNDER APPLICATION
PUMP AT MAX

OVER APPLICATION
PUMP AT MIN

These messages will only appear in the spraying operation. The over application message indicates that the ground speed is too slow and/or possibly the engine speed is too fast, while the under application message indicates that the ground speed is too fast and/or possibly the engine speed is too slow.

Hot Hydraulics

HYD TEMP
HOT

This message flashes on the display when the hydraulic reservoir temperature reaches or exceeds 200°F.

 WARNING
Stop immediately and determine the cause of the high temperature. Failure to do so will result in damage to hydraulic components.

Switch Module

SWITCH MODULE
NOT RESPONDING

This message flashes on the display when the input module in the cab control box is not present on the CAN bus. There are several reasons why the module might not be recognized on the CAN bus. It may be unplugged from the CAN bus or electrical power or may be damaged.

Hydraulic Pump

HYD PUMP EDC
OUT OF RANGE

This message flashes on the display after the START switch has been selected in AUTO pump control if the EDC is disconnected from the computer or is electrically shorted.

Motor Feedback

CHECK
HYD MOTOR

This message flashes on the display after the START switch has been selected in AUTO pump control if the asphalt pump speed remains or becomes zero for too long. This may mean that the asphalt pump will not turn or the speed sensor is not set correctly, faulty, damaged or is disconnected from the computer.

Low Level

TANK LEVEL
LOW

This message flashes on the display when in bar circulate or spray and the asphalt tank material level reaches the low level.

Radar Calibration

RADAR CALIBRATION
OUT OF RANGE

This message flashes on the display after ground speed calibration when the radar is either not connected to the computer or produces a signal that is out of the acceptable range.

Left Module / Right Module

LEFT MODULE
NOT RESPONDING

RIGHT MODULE
NOT RESPONDING

This message flashes on the display when VW control is selected and either the left module by the rear control box or the right module by the rear control box is not present on the CAN bus. There are several reasons why the module might not be recognized on the CAN bus. It may be unplugged from the CAN bus or electrical power or may be damaged.

Left Smart Cylinder / Right Smart Cylinder

LEFT SMART CYL
OUT OF RANGE

RIGHT SMART CYL
OUT OF RANGE

This message flashes on the display when VW control is selected and the feedback from either the left smart cylinder or the right smart cylinder is out of the acceptable range or has been calibrated incorrectly. There are several reasons why the feedback may be out of the acceptable range. It may be unplugged from the computer or electrical power or may be damaged.

Burner Timer

BURNER TIMER
ENDING

This message flashes on the display during the last 5 minutes of heating when the optional burner controls are installed.

LOADING

Loading Through the Manhole

To reduce the risk of accidental discharge of asphalt, the asphalt pump should not be running, the 4 way valve should be in tank circulate, all tank valves should be closed, and both the load and transfer line caps should be on and secured. when loading through the manhole.



WARNING

To prevent possible injury, always open the manhole cover slowly. Pressure build up in the tank may cause the cover to burst open.

Refer to **Figure 11** for the following procedures.

1. Park the Distributor in the desired location for loading overhead through the manhole.
2. Set the truck parking brake and turn off engine.
3. Before exiting the cab, turn the POWER switch OFF.
4. When the desired amount of product is in the tank and the supply tank valve is closed, close the manhole lid and properly secure before moving the Distributor



WARNING

To prevent possible burns from foaming or violent eruption: Do not load tank with material temperature over 200°F if water or condensation is present in tank, or if emulsion was used in the previous load. Do not heat material over 200°F if moisture or emulsion is present in tank.

Handspray Valve Positions

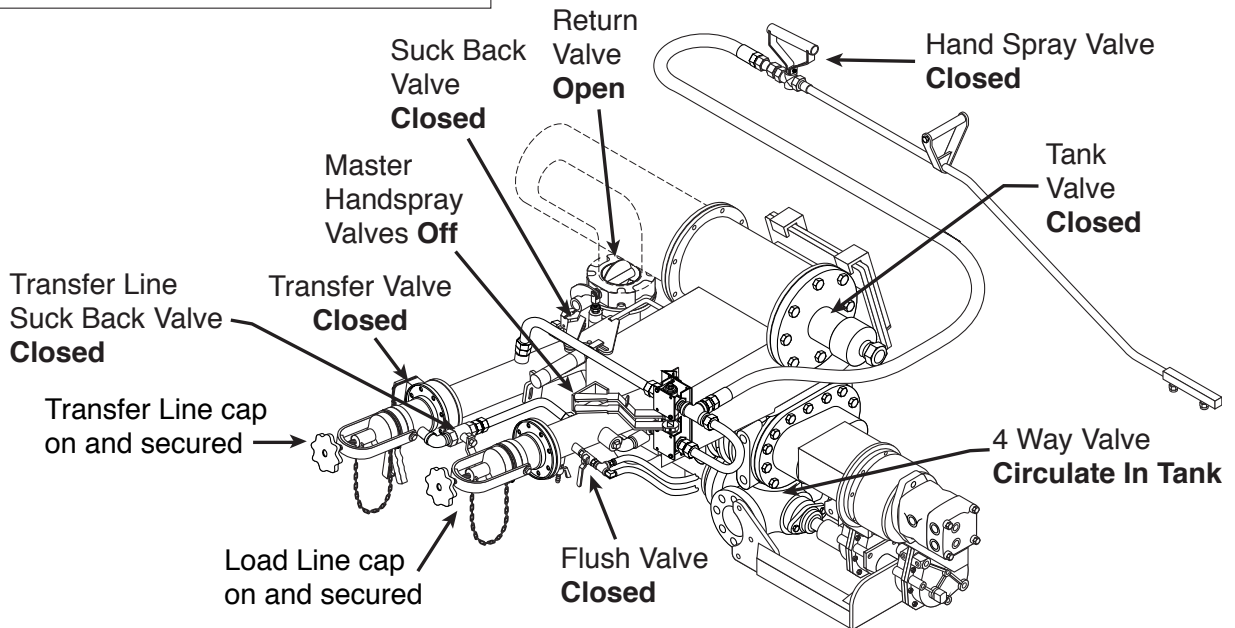
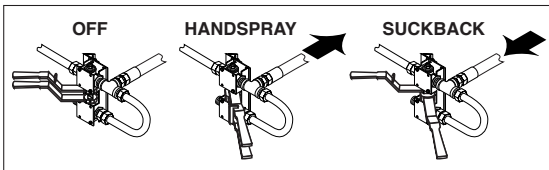

Figure 11. Valve Positions for Loading Through the Manhole

LOADING

Loading Through the Load Line

Connections and Preliminary Checks



WARNING

To prevent possible burns from leaking material, be sure all pipe, cap and hose connections are secure before opening valves or beginning any operation.



WARNING

To prevent possible burns to operators or bystanders, or possible equipment damage, do not start any operation if any control settings are unknown.



WARNING

To prevent an explosion or fire hazard, keep burning cigarettes or other sources of combustion away from manholes and overflow vents.



WARNING

To prevent burns, always wear eye protection, long sleeve shirt, insulated gloves, boots, and long pants outside the boots when working around the Distributor.

Check Strainers

Before removing the load line cap or strainer access cover perform the suck back operation to ensure that there is not material in the strainer box. Finally ensure that the tank valve(s) are closed and the POWER switch is OFF before removing the load line cap and stainer access cover.

Ensure that both the fill line and the suction strainers are clean and properly installed.

Ensure that all connections on the Distributor are tight to prevent asphalt leaks. **Do not** pressurize the fill line with an external pump.



WARNING

Before removing the fill line cap, make certain that the asphalt pump is turning and the suction valve is closed.

Using the Measuring Stick

The measuring stick is only accurate when the tank is level.

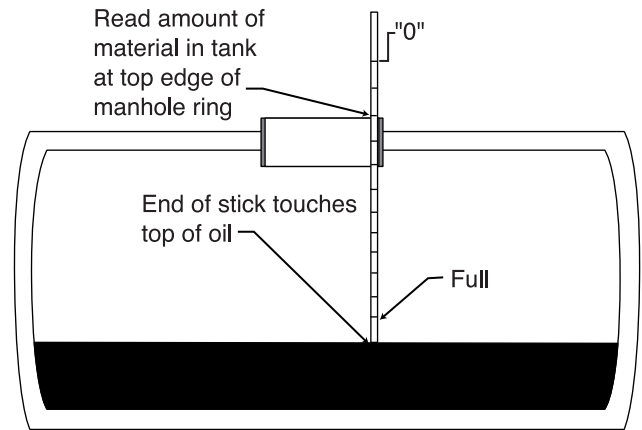

Figure 12. Using the Measuring Stick

LOADING

Loading Through the Load Line (cont)



WARNING

To prevent possible burns from foaming or violent eruption: Do not load tank with material temperature over 200°F if water or condensation is present in tank, or if emulsion was used in the previous load. Do not heat material over 200°F if moisture or emulsion is present in tank.

Refer to **Figure 13** for the following procedures.

1. Park the Distributor in the desired location for loading through the fill line.
2. Set the truck parking brake.
3. The engine must be running and the optional transmission PTO must be engaged.
4. On the cab control panel, turn the POWER switch ON.

At the rear of the distributor:

Set or confirm the following:

- Tank valve **closed**
- Return valve **open**
- Bar suck back valve(s) **closed**
- Master hand spray valve **closed**
- Transfer line suck back valve **closed**
- Transfer line valve **closed**
- Flush valve **closed**
- Load and transfer line caps are in place and secured.

At the rear of control panel:

1. Turn the Function knob to the LOAD position.
2. Turn the EMERGENCY STOP switch ON. Both the front and rear power switches must be ON to operate.
3. Turn the PUMP CONTROL switch to MANUAL.
4. Press START. Turn the PUMP SPEED knob so the asphalt pump turns slowly.
5. Remove the load line cap.

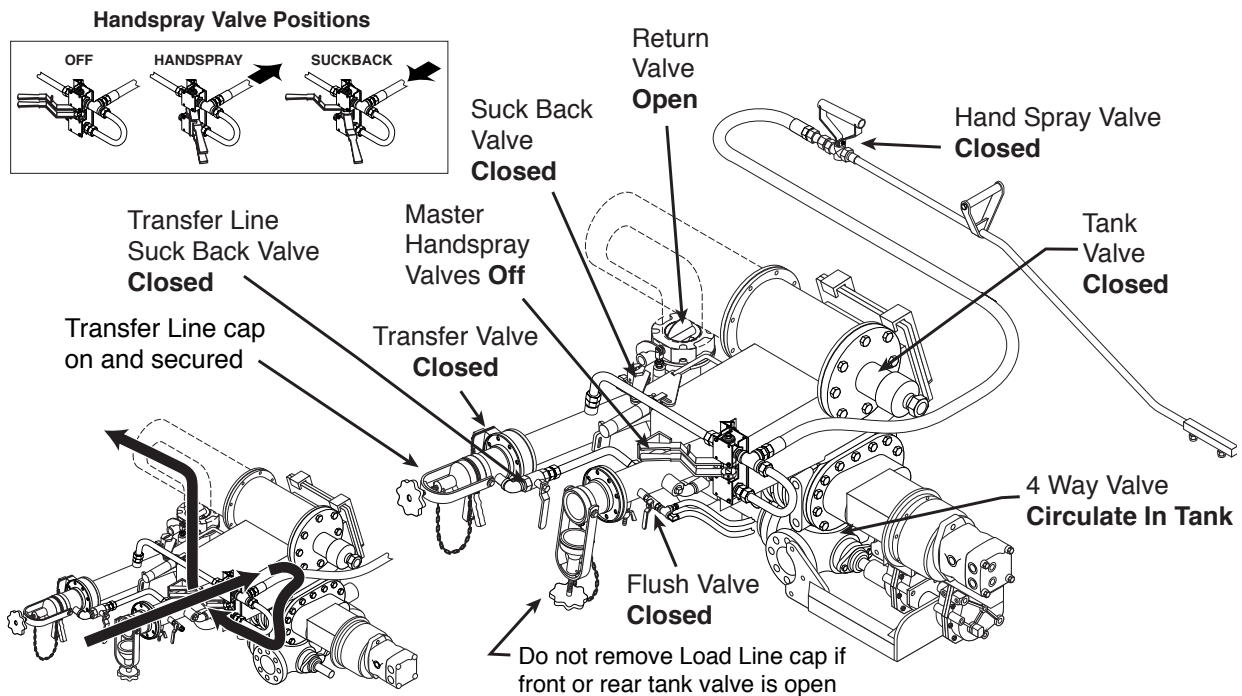

Figure 13 Valve Positions for Loading Through the Load Line

6. Connect the load line to the supply tank through an asphalt hose.
7. Open the tank valve on the supply tank.
8. Decrease the PUMP SPEED to zero.
9. Turn the PUMP CONTROL switch to AUTO.
10. Press START. The pump will start turning at the desired loading rate.
11. When the desired amount of product is in the Distributor tank, close the supply tank valve.
12. At the supply tank, carefully open the bleeder valve or break the hose connection until a strong vacuum is heard. It may be necessary to reduce the pump speed in order to overcome pump vacuum when breaking the hose connection. Elevating the hose above the load line connection will allow maximum drainage of the hose.
13. Disconnect the hose from the load line.
14. Replace the load line cap and secure.
15. If no other operation will be performed, it may be necessary to flush the pump before stopping the pump in the next step. Otherwise go to the instructions for the desired operation.
16. To stop the pump in MANUAL control select AUTO control. To stop the pump in AUTO control, with the PUMP SPEED knob fully counter clockwise select MANUAL control.

NOTE: The pump can be stopped and the automatic tank valve can be closed immediately at any time during operation by turning the EMERGENCY STOP switch OFF. Before turning the EMERGENCY STOP switch back ON, turn the PUMP SPEED knob to zero to prevent the pump from turning.

A pump rate of 100 GPM is recommended to begin the loading operation. The pump rate can be increased at any time after loading has begun.

Depending on material viscosity, as the loading rate is increased, the asphalt pump may cavitate. When this happens, the pump will make a distinctive sound, easily recognized with experience. Short periods of operation while the pump is cavitating will not damage the pump but you should not operate the pump in this condition for extended periods.

Higher pump speeds will not load thicker materials faster. Lighter materials, or heavy materials which are already at spraying temperature, may be loaded at faster rates.

 WARNING
To prevent possible burns from material overflow, allow sufficient space in the tank for expansion of the material when heating.

 WARNING
To prevent an explosion or fire hazard, keep burning cigarettes or other sources of combustion away from manholes and overflow vents.

 WARNING
To prevent burns, always wear insulated gloves when handling spray bar sections or hoses.

CIRCULATING

Circulating in the Tank

WARNING

To prevent possible burns from material overflow, allow sufficient space in the tank for expansion of the material when heating.

WARNING

To prevent burns, always wear insulated gloves when handling spray bar sections or hoses.

If the product is too cold to be circulated, some heating with the burners will be needed to increase the temperature enough to be able to start circulating. Refer to the portion of this operating manual for instructions on your particular type of burner.

Refer to **Figure 14** for the following procedures.

1. If heating, park the Distributor broadside to the wind.
2. Set the truck parking brake.

3. The engine must be running and the optional transmission PTO must be engaged.
4. On the cab control panel, turn the POWER switch ON.

At the rear of the distributor:

Set or confirm the following:

- Return valve **open**
- Bar suck back valve(s) **closed**
- Master hand spray valve **closed**
- Transfer line suck back valve **closed**
- Transfer line valve **closed**
- Flush valve **closed**
- Load and transfer line caps are in place and secured.

At the rear of control panel:

1. Turn the Function knob to TANK CIRCULATE. (Optional manual tank valve should be opened.)
2. Turn the EMERGENCY STOP switch ON.
3. Put the PUMP CONTROL to AUTO.

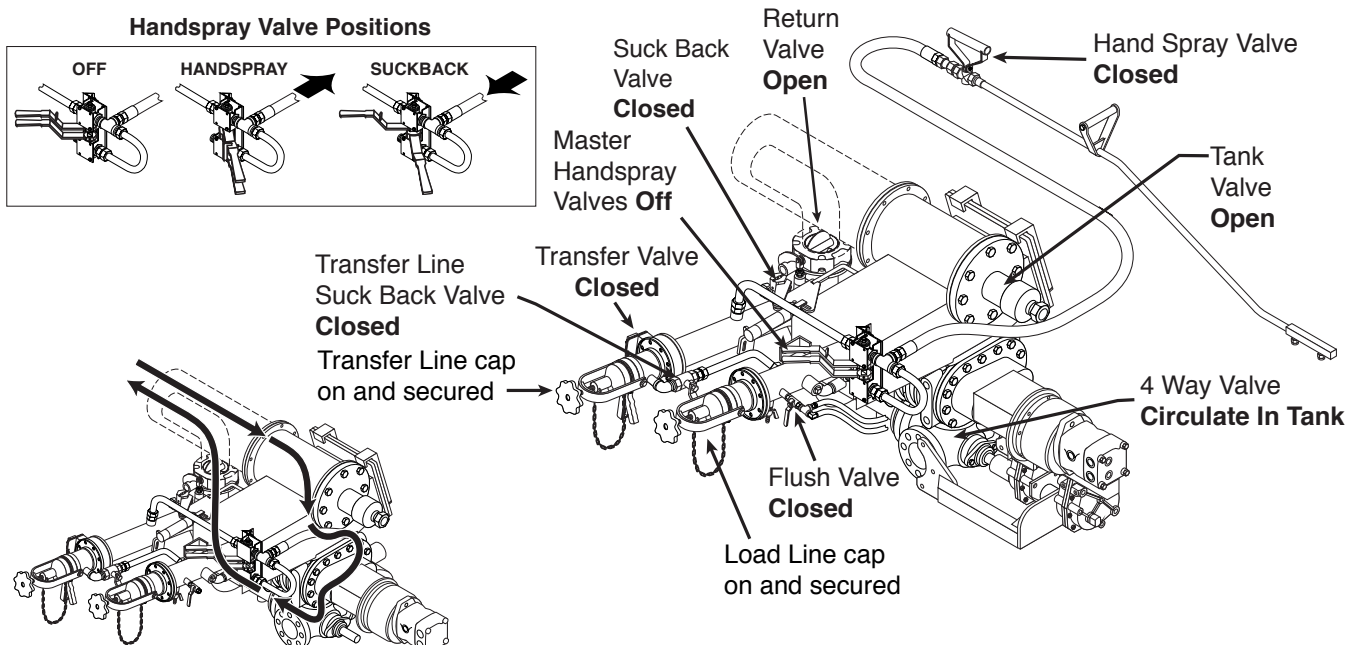

Figure 14. Valve Positions for Circulating in the Tank

4. Press START. The pump will start turning at the desired circulation rate.
5. If no other operation will be performed, go to the next step. Otherwise go to the instructions for the desired operation.
6. The optional manual tank valve should be closed at this time before stopping the pump.
7. To stop the pump in MANUAL control select AUTO control. To stop the pump in AUTO control, with the PUMP SPEED knob fully counter clockwise select MANUAL control.
8. Flush the pump if necessary before quitting.

NOTE: The pump can be stopped and the automatic tank valve can be closed immediately at any time during operation by turning the EMERGENCY STOP switch OFF. Before turning the EMERGENCY STOP switch back ON, turn the PUMP SPEED to zero to prevent the pump from turning.



WARNING

To prevent possible burns, use extreme caution when using a torch to heat the pump. Asphalt accumulated around the pump may ignite when heating the pump with a torch.



WARNING

To prevent an explosion or fire hazard, when the burners go out, shut off the fuel supply to both burners and allow the flues to ventilate for at least 3 minutes before re-lighting the burners.



WARNING

To prevent an explosion, do not operate the burners when the vehicle is unattended, when the vehicle is in motion, or with the vehicle in a confined area.



WARNING

To prevent possible burns from material overflow, allow sufficient space in the tank for expansion of the material when heating.

CIRCULATING

Circulating Product in the Bar

Refer to **Figure 15** for the following procedures.

1. If heating, park the Distributor broadside to the wind.
2. Set the truck parking brake.
3. The engine must be running and the optional transmission PTO must be engaged.
4. Turn the SPRAY switch OFF.
5. Set the application rate with a MEMORY switch or by using the SELECT and VALUE switches.
6. Set the desired spray width with the One Foot switches. The spray bar should always be warmed before moving it in order obtain the desired spray width. Lowering the wings allow for increased spray width selections.
7. Turn the POWER switch ON in the cab panel.

At the rear of the distributor:

Set or confirm the following:

- Return valve **open**
- Bar suck back valve(s) **closed**
- Master hand spray valve **closed**
- Transfer line suck back valve **closed**
- Transfer line valve **closed**
- Flush valve **closed**
- Load and transfer line caps are in place and secured.

At the rear control panel:

1. Turn the Function knob to BAR CIRCULATE. (Optional manual tank valve should be opened.)
2. Turn the EMERGENCY STOP switch ON.
3. Put the PUMP CONTROL to AUTO.
4. Press START. The pump will start turning at the desired circulation rate.
5. If no other operation will be performed, go to the next step. Otherwise go to the instructions for the desired operation.

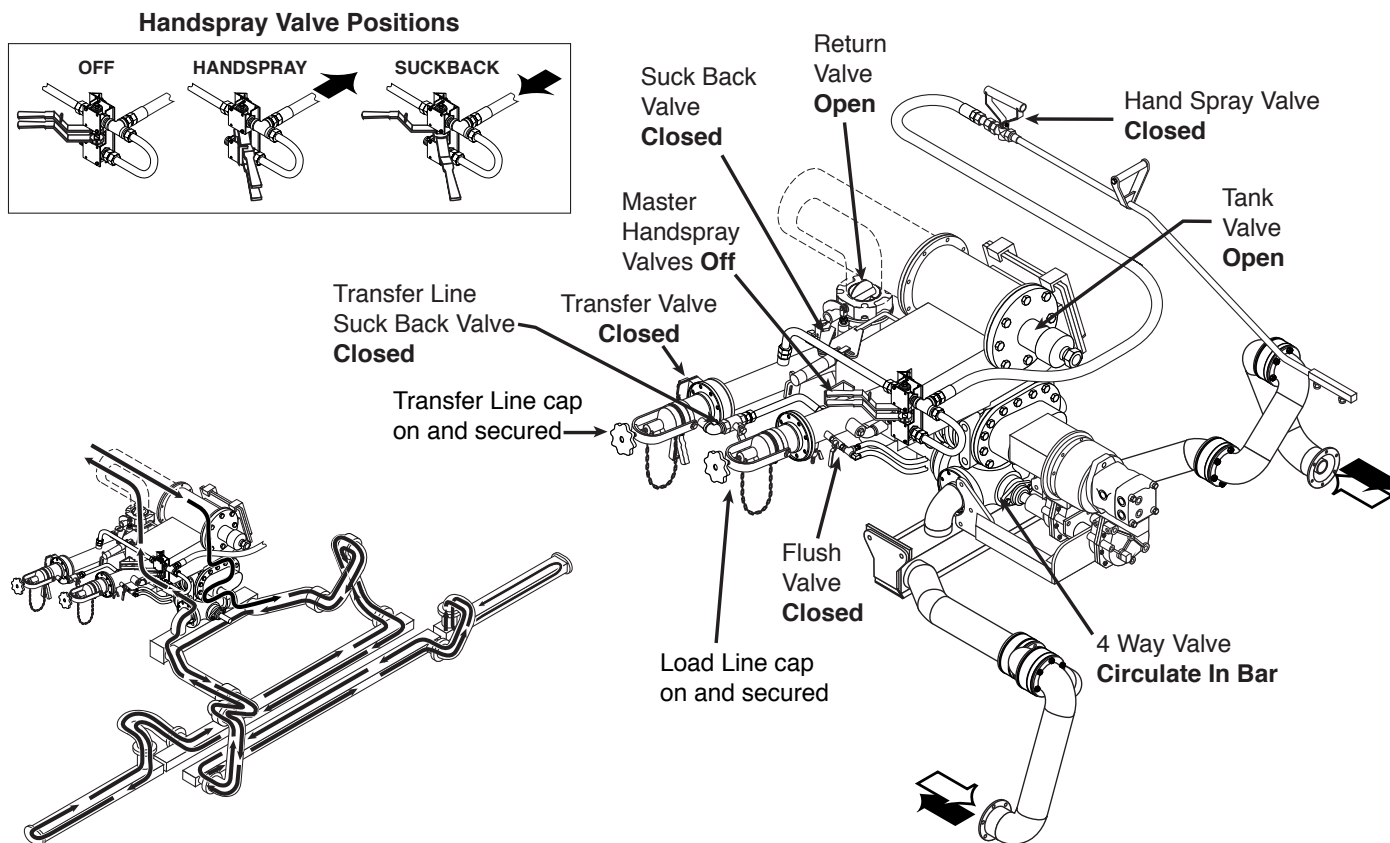

Figure 15. Valve Positions for Circulating in the Bar

NOTE: The pump can be stopped and the automatic tank valve can be closed immediately at any time during operation by turning the EMERGENCY STOP switch OFF. Before turning the EMERGENCY STOP switch back ON, turn the PUMP SPEED to zero to prevent the pump from turning.

Circulate product long enough to ensure removal of all air from the bar and to heat the spray bar valves sufficiently. For better material circulation, in the bar ends, the wings should be lowered. Before moving the bar, circulate some hot material through the bar. This allows the bar to warm up and also extends the life of the bar seals and o-rings.



WARNING

To prevent an explosion or fire hazard, ensure that the burners are extinguished before removing any material from the tank in any manner. Liquid petroleum (LP) burners can support a flame for several minutes after the fuel supply is turned off.



CAUTION

To prevent excessive pressure in the spray bar, the asphalt pump speed should not exceed 160 GPM while circulating in the spray bar.

SPRAYING

Spraying Through the Bar

Refer to **Figure 16** for valve positions.

1. Complete the procedure for circulating in the spray bar. See the *Circulating Product in the Bar* section of this manual.
2. Unlatch the spray bar.
3. Lower the spray bar to the desired spray height.
4. Set the desired spray width using the One Foot switches and configuring the spray bar to the desired width with the wings. Extend or retract the right and left spray bars as needed.
5. Select the transmission gear and rear axle speed that produces the desired engine and ground speed for spraying.
6. Release the parking brake and start the Distributor moving.

7. When the spray bar reaches the beginning of the shot, turn the SPRAY switch ON.
8. When the spray bar reaches the end of the shot turn the SPRAY switch OFF.
9. Continue spraying by turning ON and OFF the SPRAY switch as desired. When finished, follow the instructions for bar suck back. See the *Spray Bar Suck Back* section of this manual.

WARNING

Do not run the pump above rated capacity of 400 GPM. Damage to equipment may occur.

WARNING

To prevent an explosion or fire hazard, do not operate the burners while spraying.

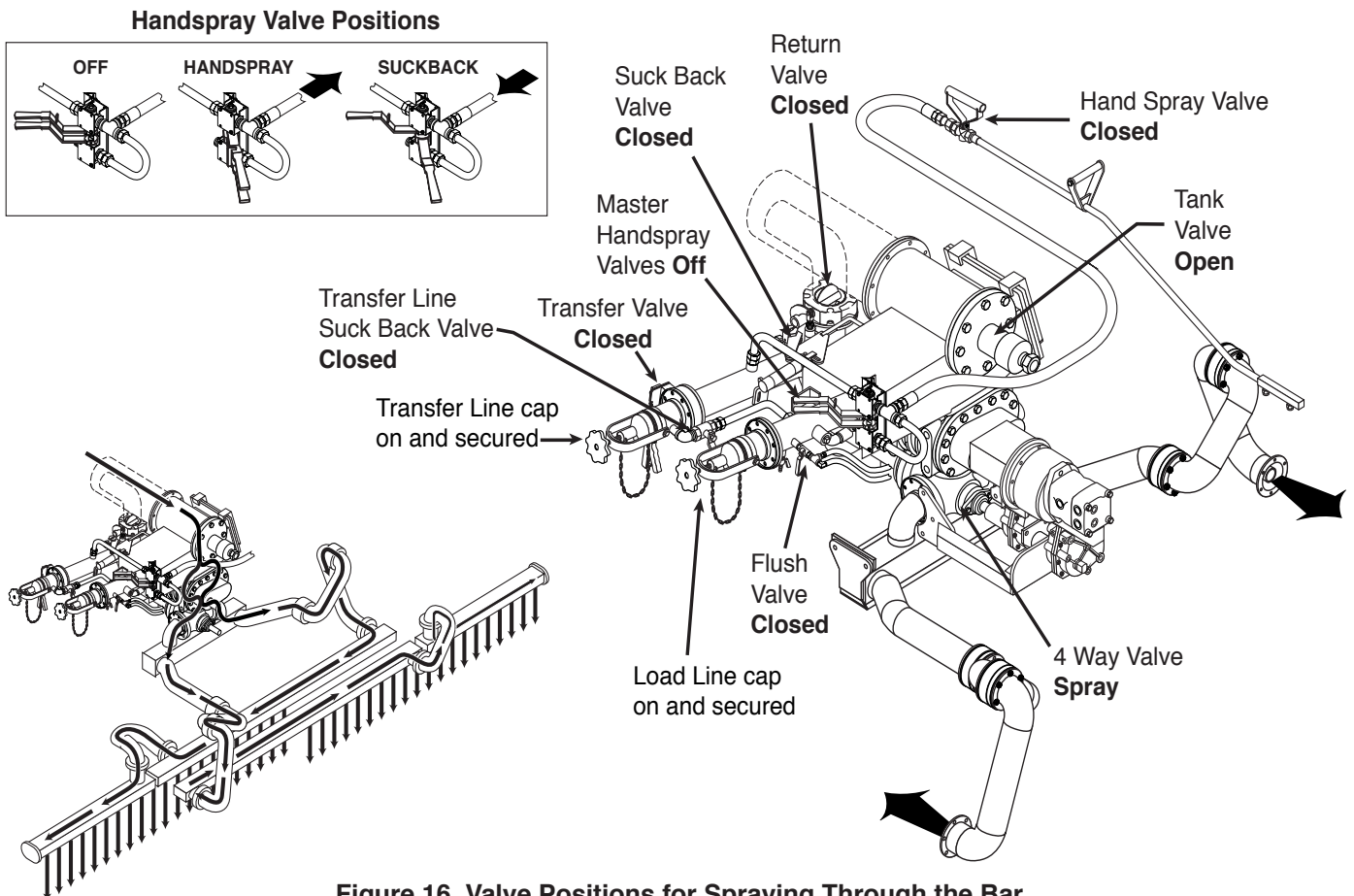

Figure 16. Valve Positions for Spraying Through the Bar

SPRAYING

Hand Spraying

Refer to **Figure 17** for the following procedure.



WARNING

To prevent burns from hot asphalt when handspraying, hold the handspray gun in proper position and watch for other people.



WARNING

To prevent burns, always wear eye protection, long sleeve shirt, insulated gloves, boots, and long pants outside the boots when working around the Distributor.

1. Set the truck parking brake.
2. The engine must be running and the optional transmission PTO must be engaged.
3. On the cab control panel, turn the POWER switch ON.

At the rear of the distributor:

Set or confirm the following:

- Return valve **closed**
- Bar suck back valve(s) **closed**
- Master hand spray valve **closed**
- Transfer line suck back valve **closed**

- Transfer line valve **closed**
- Flush valve **closed**
- Load and transfer line caps are in place and secured.

At the rear control panel:

1. Turn the Function knob to HAND SPRAY. (Optional manual tank valve should be open)
2. Turn the EMERGENCY STOP switch ON.
3. Put the PUMP CONTROL to AUTO.
4. Press START. The pump will start turning at the desired rate.
5. Move the master hand spray valve into the hand spray position.
6. Open the hand spray valve on the hand spray wand.
7. Gradually increase the asphalt pump speed to increase hand spray pressure.
8. Continue hand spraying by opening and closing the hand spray valve on the wand as needed.
9. When finished, close the handspray valve on the wand.

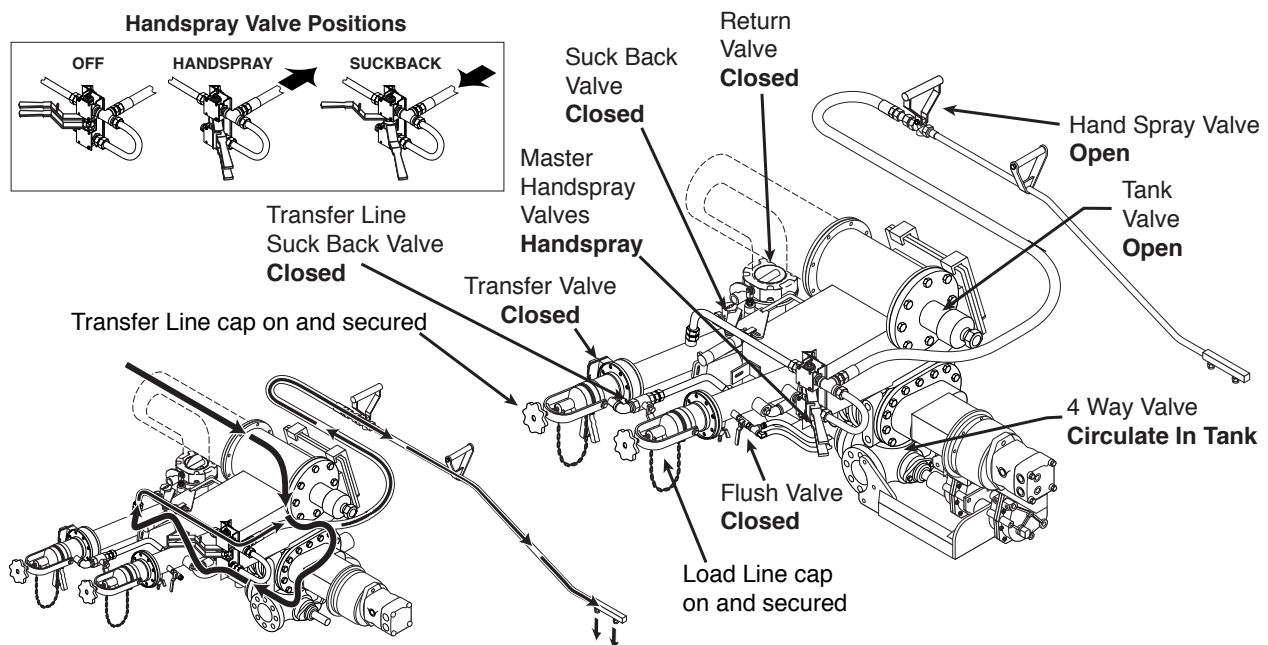

Figure 17. Valve Positions for Handspray

SUCKBACK

Spray Bar Suckback

Refer to **Figure 18** for the following procedures.

1. Park the Distributor and set the truck parking brake.
2. The engine must be running and the optional transmission PTO must be engaged.
3. On the cab control panel, turn the POWER switch ON.

At the rear of the distributor:

Set or confirm the following:

- Tank valve **closed**
- Return valve **open**
- Master hand spray valve **closed**
- Transfer line suck back valve **closed**
- Transfer line valve **closed**
- Flush valve **closed**
- Load and transfer line caps are in place and secured.

At the rear control panel:

1. Turn the Function knob to SUCK BACK. (Optional manual tank valve should be closed and the optional manual bar suck back valve(s) should be open.)
2. Turn the EMERGENCY STOP switch ON.
3. Put the PUMP CONTROL to AUTO.
4. Press START. The pump will start turning at the desired rate. 200 GPM is recommended.
5. Open the bleeder valve on the left wing until a strong vacuum is heard and then close valve.
6. Open the bleeder valve on the right wing until strong vacuum is heard and then close valve.
7. If no other operation will be performed, go to the next step. Otherwise go to the instructions for the desired operation.
8. Close the optional manual bar suck back valve.
9. To stop the pump in MANUAL control select AUTO control. To stop the pump in AUTO control with the PUMP SPEED knob fully counter clockwise select MANUAL control.
10. Flush the pump if necessary before quitting.

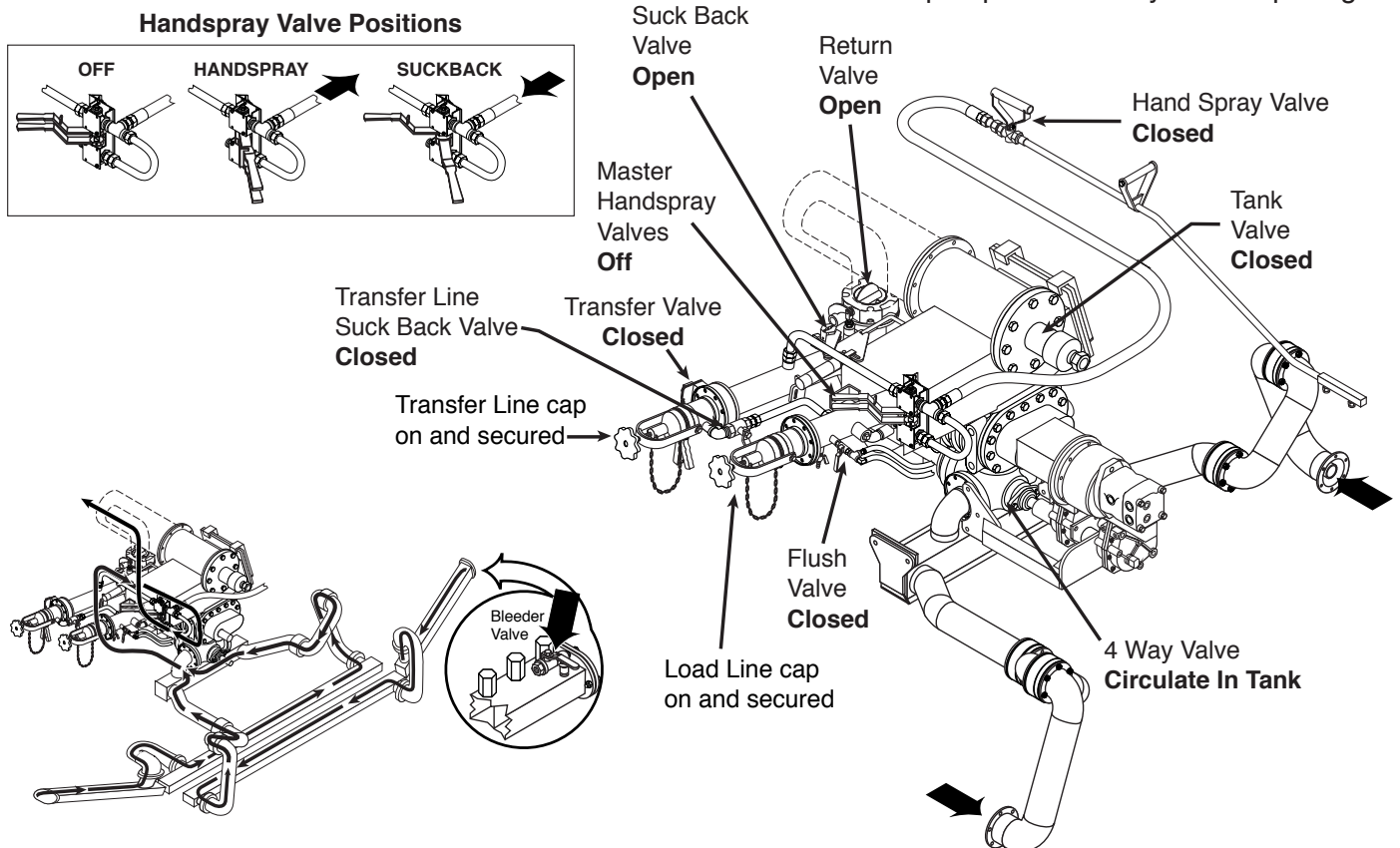

Figure 18. Valve Positions for Spray Bar Suck Back

NOTE: The pump can be stopped and the automatic tank valve can be closed immediately at any time during operation by turning the EMERGENCY STOP switch OFF. Before turning the EMERGENCY STOP switch back ON, turn the PUMP SPEED to zero to prevent the pump from turning.



WARNING

To prevent possible burns from hot asphalt spray, do not stand, or allow anyone to stand, where accidental opening of a valve may cause contact with hot asphalt.

For asphalts like AC it is recommended that this procedure be repeated a second time, after which adding solvent such as diesel fuel through each bleeder will quickly flush the spray bar.

If not equipped with the electric pump, it is helpful to pour some diesel fuel down the fill line after all operations are completed. The diesel fuel will remain in the pump overnight to keep the pump free for the next morning's operation.

Ensure that the self flush valve is closed at the end of this function, or before loading or circulating asphalt to eliminate chances of inducing asphalt into the self flush fuel tank.



CAUTION

When using rear pump control, engine RPM changes will affect asphalt pump speed.

SUCKBACK

Suck Back Override

This optional feature is designed for quick in-cab switching between bar circulate and bar suck back for units equipped with automatic tank and bar suck back valves. When the SUCK BACK OVERRIDE switch is ON, all automatically controlled valves are set to their correct positions for SUCK BACK. This overrides any settings of the Function knob and also stops the asphalt pump.

The following steps performed in the cab while the Function knob is turned to BAR CIRCULATE.

1. Turn the SUCK BACK OVERRIDE switch ON.
2. Press START. The pump will start turning at the desired rate. 200 GPM is recommended.
3. If complete bar suck back is desired, follow the instructions for bar suck back, beginning with the opening of the left bleeder valve. Otherwise continue to the next step.
4. Turn the SUCK BACK OVERRIDE switch OFF.
5. Press START. The pump will start turning at the desired circulation rate.

Note: The pump can be stopped and the automatic tank valve can be closed immediately at any time during operation by turning the EMERGENCY STOP switch OFF. Before turning the EMERGENCY STOP switch back ON, turn the PUMP SPEED to zero to prevent the pump from turning.



CAUTION

When using rear pump control, engine RPM changes will affect asphalt pump speed.



WARNING

To prevent burns, always wear eye protection, long sleeve shirt, insulated gloves, boots and long pants outside the boots when working around the Distributor.

SUCKBACK

Handspray Suckback



WARNING

To prevent burns from hot asphalt when handspraying, hold the handspray gun in proper position and watch for other people.



WARNING

To prevent burns, always wear eye protection, long sleeve shirt, insulated gloves, boots and long pants outside the boots when working around the Distributor.

1. Turn the Function knob to SUCK BACK. (Optional manual tank valve should be closed)
2. Press START. The pump will start turning at the desired rate, 200 GPM is recommended.
3. Move the master hand spray valve into the suck back position.
4. Open the hand spray valve on the hand spray wand until a strong vacuum is heard and then close the valve.
5. If no other operation will be performed, go to the next step. Otherwise go to the instructions for the desired operation.
6. To stop the pump in MANUAL control select AUTO control. To stop the pump in AUTO control with the PUMP SPEED knob fully counter clockwise select MANUAL control.
7. Flush the pump if necessary before quitting.

NOTE: The pump can be stopped and the automatic tank valve can be closed immediately at any time during operation by turning the EMERGENCY STOP switch OFF. Before turning the EMERGENCY STOP switch back ON, turn the PUMP SPEED to zero to prevent the pump from turning.



WARNING

To prevent possible burns from hot asphalt spray, do not stand, or allow anyone to stand, where accidental opening of a valve may cause contact with hot asphalt.

For asphalts like AC it is recommended that this procedure be repeated a second time, after which adding solvent such as diesel fuel through the nozzles of the hand spray wand will quickly flush the hand spray wand and hose.

If not equipped with the electric pump, it is helpful to pour some diesel fuel down the fill line after all operations are completed. The diesel fuel will remain in the pump overnight to keep the pump free for the next morning's operation.

Ensure that the self flush valve is closed at the end of this function, or before loading or circulating asphalt to eliminate chances of inducing asphalt into the self flush fuel tank.



CAUTION

When using rear pump control, engine RPM changes will affect asphalt pump speed.

FLUSHING OPERATIONS

Normally the suckback procedure will remove sufficient material from the circulating system to negate the need for draining the circulating system and spray bar before proceeding with the wash out operation. The flushing operation requires only three quarts of flushing solvent. This small amount is not sufficient to fill the lines to the tank, thus preventing solvent from being forced into the tank.

A common practice following completion of the flushing procedure and subsequent shutdown is to pour one to two quarts of solvent into the fill line. This softens or dissolves the residual asphalt in the pump. Allow these solvents to remain in the system until the next use.

Bar Flush (Auto)

Refer to **Figure 19** for the following procedures.

1. Park the Distributor and set the truck parking brake.
2. The engine must be running and the optional transmission PTO must be engaged.
3. On the cab control panel, turn the POWER switch ON.

At the rear of the distributor:

Set or confirm the following:

- Tank valve **closed**
- Bar suck back valve(s) **closed**
- Return valve **open**
- Master hand spray valve **closed**
- Transfer line suck back valve **closed**
- Transfer line valve **closed**
- Load and transfer line caps are in place and secured.

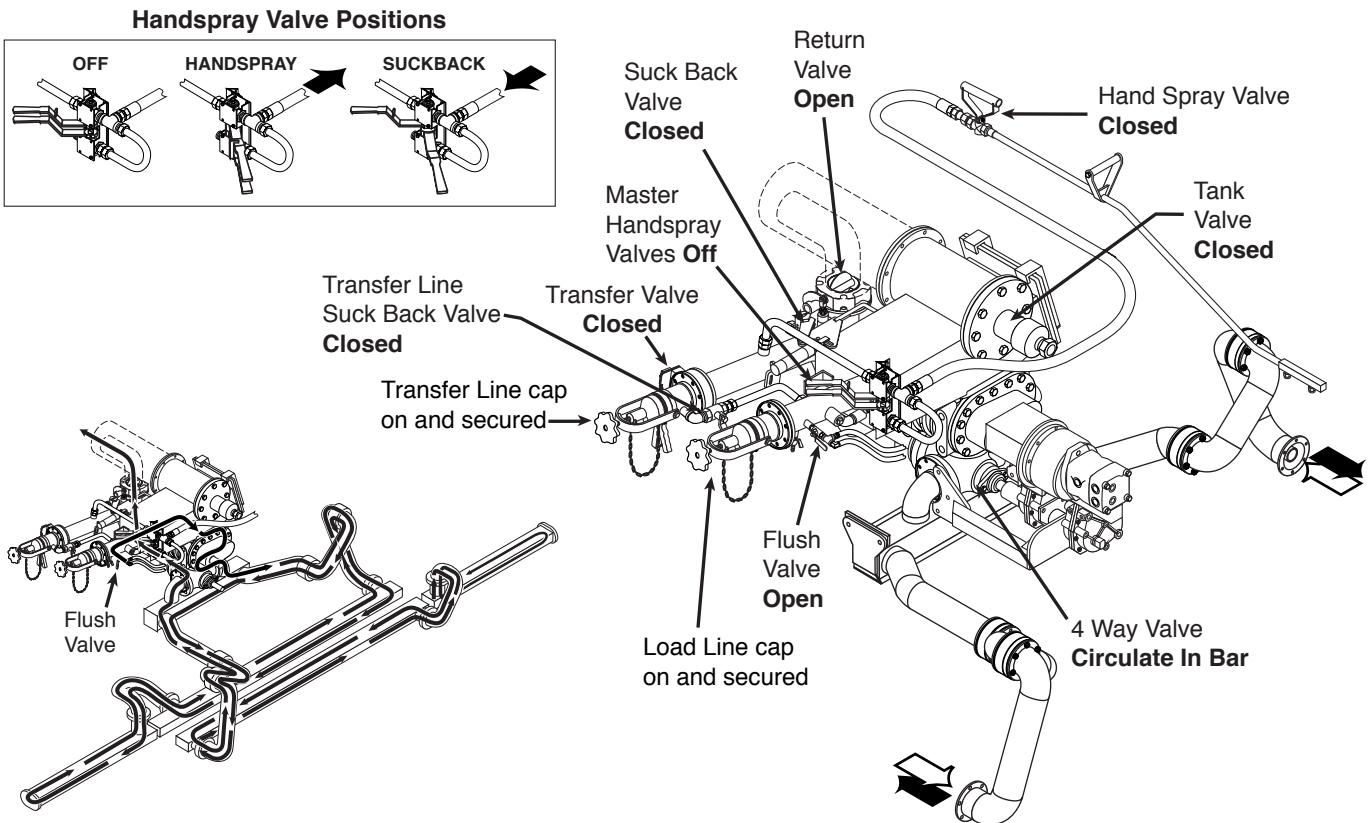

Figure 19. Valve Positions for Flushing

At the rear control panel:

1. Turn the Function knob to FLUSH.
2. Turn the EMERGENCY STOP switch ON.
3. Put the PUMP CONTROL to AUTO.
4. Press START. The pump will start turning at the desired circulation rate.
5. Open the flush valve for 2 minutes.
6. Close the flush valve.
7. If no other operation will be performed, go to the next step. Otherwise go to the instructions for the desired operation.
8. To stop the pump in MANUAL control select AUTO control. To stop the pump in AUTO control with the PUMP SPEED knob fully counter clockwise select MANUAL control.

NOTE: The pump can be stopped and the automatic tank valve can be closed immediately at any time during operation by turning the EMERGENCY STOP switch OFF. Before turning the EMERGENCY STOP switch back ON, turn the PUMP SPEED to zero to prevent the pump from turning.

Bar Flush (Manual)

Refer to Figure 14 for the following procedures.

1. Park the Distributor and set the truck parking brake.
2. The engine must be running and the optional transmission PTO must be engaged.
3. On the cab control panel, turn the POWER switch ON.

At the rear of the distributor:

Set or confirm the following:

- Tank valve **closed**
- Return valve **open**
- Master hand spray valve **closed**
- Transfer line suck back valve **closed**
- Transfer line valve **closed**
- Flush valve **closed**
- Load and transfer line caps are in place and secured.

At the rear control panel:

1. Turn the Function knob to SUCK BACK.
2. Turn the EMERGENCY STOP switch ON.
3. Put the PUMP CONTROL to AUTO.
4. Press START. The pump will start turning at the desired rate. 200 GPM is recommended.
5. Open the bleeder valve on the left wing. After a strong vacuum is heard, add 1 quart of solvent through the valve and then close the valve.
6. Open the bleeder valve on the right wing. After a strong vacuum is heard, add 1 quart of solvent through the valve and then close the valve.
7. If no other operation will be performed, go to the next step. Otherwise go to the instructions for the desired operation.
8. To stop the pump in MANUAL control select AUTO control. To stop the pump in AUTO control with the PUMP SPEED knob fully counter clockwise select MANUAL control.
9. Flush the pump if necessary before quitting.

NOTE: The pump can be stopped and the automatic tank valve closed immediately at any time during operation by turning the EMERGENCY STOP switch OFF. Before turning the EMERGENCY STOP switch back ON, turn the PUMP SPEED to zero to prevent the pump from turning.

FLUSHING OPERATIONS

Enviro Flush System (OPTIONAL)

The Enviro-Flush system is a closed system which pulls flushing solvent from the Flush Tank, pumps it through the circulating system and spray bar and returns the solvent to the Flush Tank (Refer to **Figure 20**).

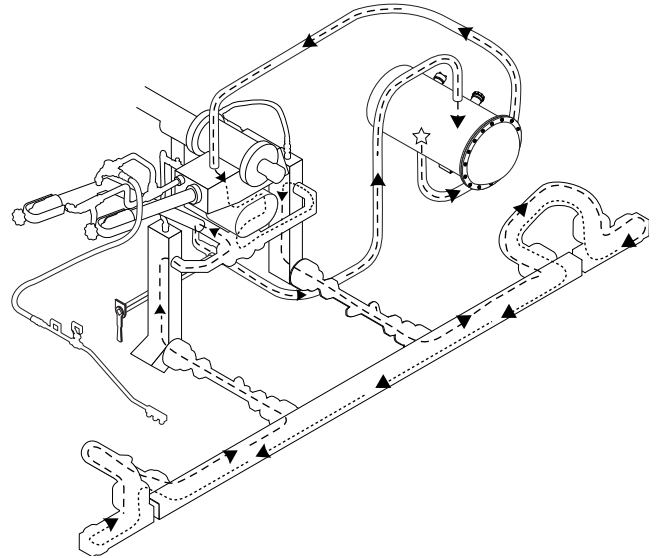

Figure 20. Enviro-Flush Flow Diagram

Recirculating Flushing Operation

Complete the appropriate suck back procedure(s) found earlier in this manual. Normally the suck-back procedure will remove sufficient material from the circulating system to negate the need for performing the Enviro-Flush procedure. Flushing Solvent must be in the Enviro-Flush tank for this procedure.

Refer to **Figure 21** for the following procedures.

At the cab control panel:

Turn on the POWER switch.

At the rear control panel:

1. Turn the FUNCTION knob to AUX.
2. Turn the EMERGENCY STOP switch ON.
3. Put the PUMP CONTROL to AUTO.
4. Press START. The pump will start turning at the desired circulation rate (50 GPM).
5. Open all three Enviro-Flush valves in order: The Enviro-Flush Return Valve ①, then the Strainer Box Valve ② and finally the Enviro-Flush Tank Valve ③.
6. After 1-2 minutes close the Enviro-Flush Tank Valve ③ and then the Strainer Box Valve ②.
7. Put the PUMP CONTROL to MANUAL to stop the pump.
8. Turn the FUNCTION knob to SUCK BACK.
9. Press START. Turn the PUMP SPEED knob to obtain 50 GPM (confirm rate on display).

10. Press START. The pump will start turning at the desired circulation rate (50 GPM).
11. Open the bleeder valve on the left wing for 1 minute and then close the valve.
12. Open the bleeder valve on the right wing for 1 minute and then close the valve.
13. Turn the FUNCTION knob to HOME to stop the pump.
14. Close the Enviro-Flush Return Valve ①.

Complete the appropriate suckback procedure(s) found earlier in this manual.



NOTE

To stop the pump in MANUAL control select AUTO control. To stop the pump in AUTO control with the PUMP SPEED knob fully counter clockwise select MANUAL control. The pump can be stopped and the automatic tank valve can be closed immediately at any time during any operation by turning the EMERGENCY STOP switch OFF. Before turning the EMERGENCY STOP switch back ON, turn the PUMP SPEED to zero to prevent the pump from turning.

FLUSHING OPERATIONS

Recycle Enviro Flush

NOTE: This procedure will transfer material from the Enviro-Flush tank to the Asphalt Tank.

Normally the suckback procedure will remove sufficient material from the circulating system to negate the need for performing the Enviro-Flush procedure. The frequency of recycling the Enviro-Flush spent solvent is then dependant upon the operator's use of the suck back feature and the type of material being flushed.

At the cab control panel:

Turn on the POWER switch.

At the rear control panel:

1. Turn the FUNCTION knob to LOAD.
2. Turn the EMERGENCY STOP switch ON.
3. Put the PUMP CONTROL to MANUAL.
4. Press START. Turn the PUMP SPEED knob to obtain 50 GPM (confirm rate on display).
5. Open the Strainer Box Valve (2) and then the Enviro-Flush Tank Valve (3).
6. When the desired amount of material is removed from the Enviro-Flush Tank close the Enviro-Flush Tank Valve (3) and then the Strainer Box Valve (2).
7. Turn the FUNCTION knob to HOME to stop the pump.

8. Refill Enviro-Flush Tank with new solvent. Complete the appropriate suckback procedure(s) found earlier in this manual.



WARNING

To prevent possible burns from foaming or violent eruption:

Do not transfer the contents of the Enviro-Flush Tank if the material temperature in the Asphalt Tank is over 200°F or if water and/or condensation is present in the Enviro-Flush Tank or if emulsion was previously flushed with the Enviro-Flush system.



NOTE

To stop the pump in MANUAL control select AUTO control. To stop the pump in AUTO control with the PUMP SPEED knob fully counter clockwise select MANUAL control. The pump can be stopped and the automatic tank valve can be closed immediately at any time during any operation by turning the EMERGENCY STOP switch OFF. Before turning the EMERGENCY STOP switch back ON, turn the PUMP SPEED to zero to prevent the pump from turning.

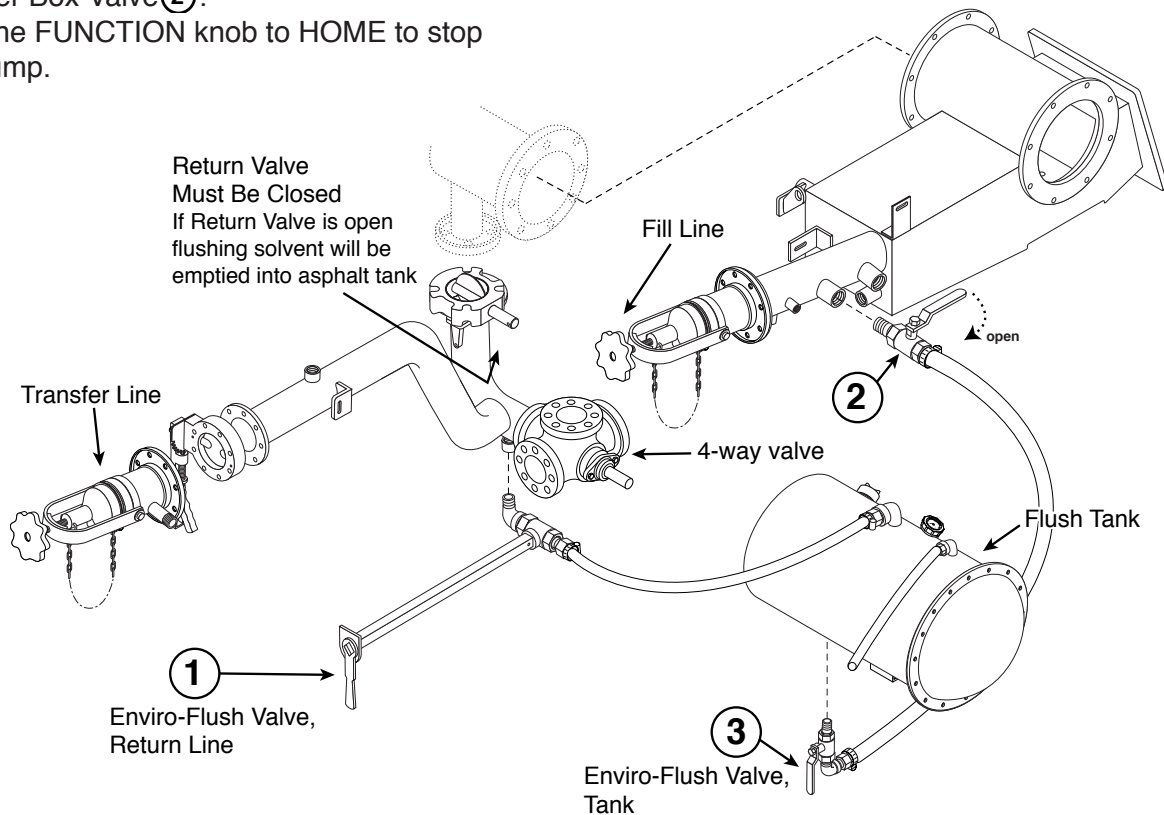

Figure 21. Recirculating Flushing System Operation

UNLOAD OPERATIONS

with External Pump

Refer to **Figure 22** for the following procedures.

1. Park the Distributor in the desired location for unloading through the load line.
2. Set the truck parking brake.
3. The engine must be running and the optional transmission PTO must be engaged.
4. On the cab control panel, turn the EMERGENCY STOP switch ON.

⚠ WARNING

To prevent burns, always wear insulated gloves when handling spray bar sections or hoses.

At the rear of the distributor:

Set or confirm the following:

- Tank valve **closed**
- Return valve **open**

- Bar suck back valve(s) **closed**
- Master hand spray valve **closed**
- Transfer line suck back valve **closed**
- Transfer line valve **closed**
- Flush valve **closed**
- Load and transfer line caps are in place and secured.

At the rear control panel:

1. Turn the Function knob to LOAD. (Optional manual tank valve should be closed.)
2. Turn the EMERGENCY STOP switch ON.
3. Put the PUMP CONTROL to MANUAL.
4. Press START. Increase the PUMP SPEED knob so that the asphalt pump turns slowly.
5. Remove the load line cap.
6. Connect the load line to the storage tank through an asphalt hose.
7. Decrease the PUMP SPEED to zero.
8. Put the PUMP CONTROL to AUTO

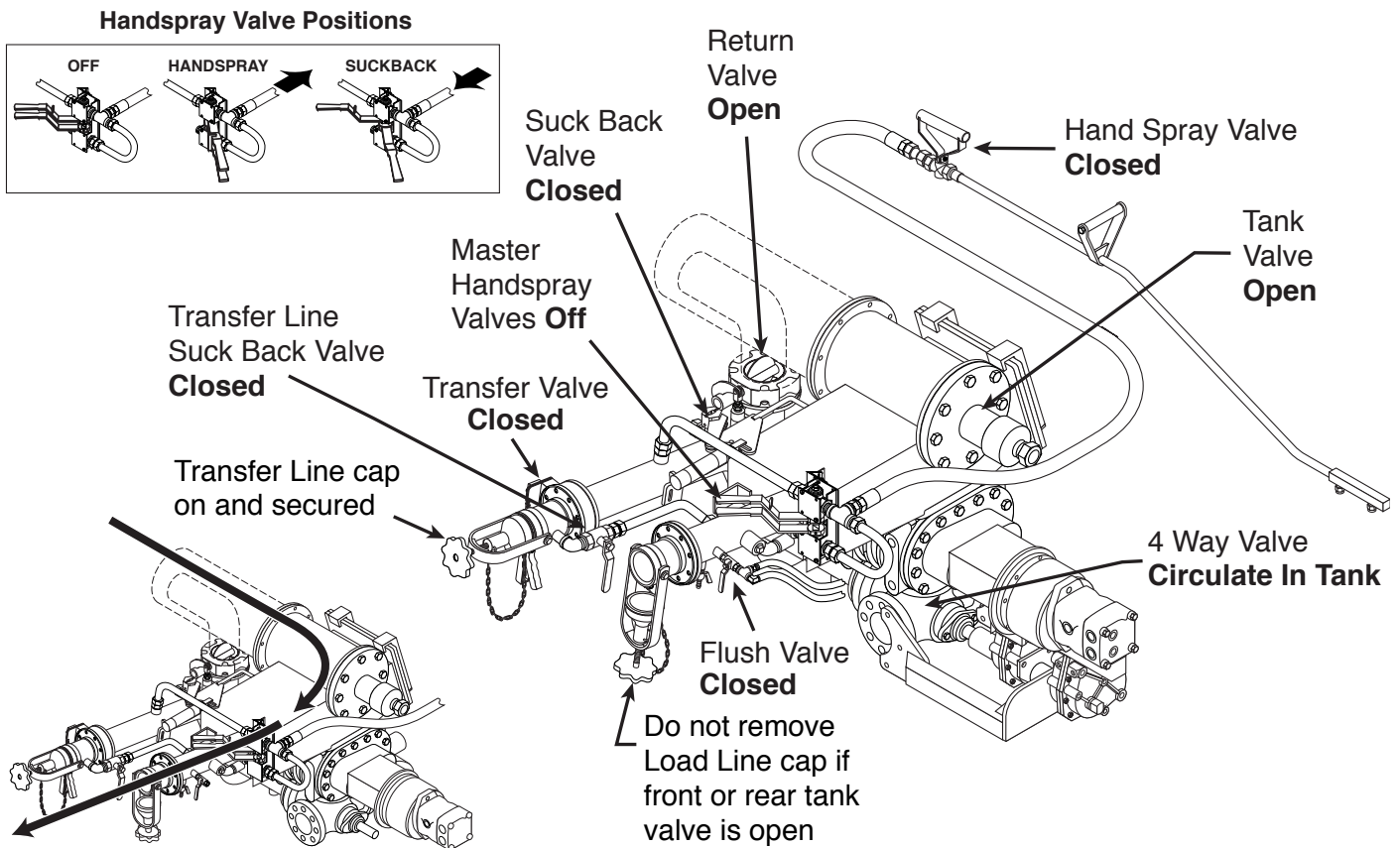

Figure 22. Valve Positions for Unload with External Pump

9. Turn the Function knob to UNLOAD
(the optional manual tank valve should be open).
10. Open any valves on the storage tank between the asphalt hose and the tank.
11. Run the asphalt pump on the storage tank at the desired pump speed.
12. When finished unloading, turn the Function knob to HOME (the optional manual tank valve should be closed).
13. As the load line on the Distributor is being unloaded, carefully open the bleeder valve or break the hose connection until a strong vacuum is heard. It may be necessary to reduce the pump speed in order to overcome pump vacuum when breaking the hose connection. Elevating the hose above the storage tank connection will allow maximum drainage of the hose.
14. Disconnect the hose from the load line.
15. Replace the load line cap and secure.
16. Flush the pump before quitting.

NOTE: The pump can be stopped and the automatic tank valve can be closed immediately at any time during operation by turning the EMERGENCY STOP switch OFF. Before turning the EMERGENCY STOP switch back ON, turn the PUMP SPEED to zero to prevent the pump from turning.



WARNING

To prevent burns, always wear insulated gloves when handling spray bar sections or hoses.

UNLOAD OPERATIONS

with Distributor Pump

Refer to **Figure 23** for the following procedures.

1. Park the Distributor in the desired location for unloading through the load line.
2. Set the truck parking brake.
3. The engine must be running and the optional transmission PTO must be engaged.
4. On the cab control panel, turn the POWER switch ON.



WARNING

To prevent burns, always wear insulated gloves when handling spray bar sections or hoses.

At the rear of the distributor:

Set or confirm the following:

- Tank valve **closed**
- Bar suck back valve(s) **closed**
- Master hand spray valve **closed**
- Transfer line suck back valve **closed**
- Transfer line valve **closed**
- Flush valve **closed**
- Load, and unload and transfer line caps are in place and secured.

At the rear control panel:

1. Remove the transfer line cap.
2. Connect the transfer line to the storage tank with an asphalt hose.
3. Open the transfer valve.
4. Open any valves on the storage tank between the asphalt hose and the tank.

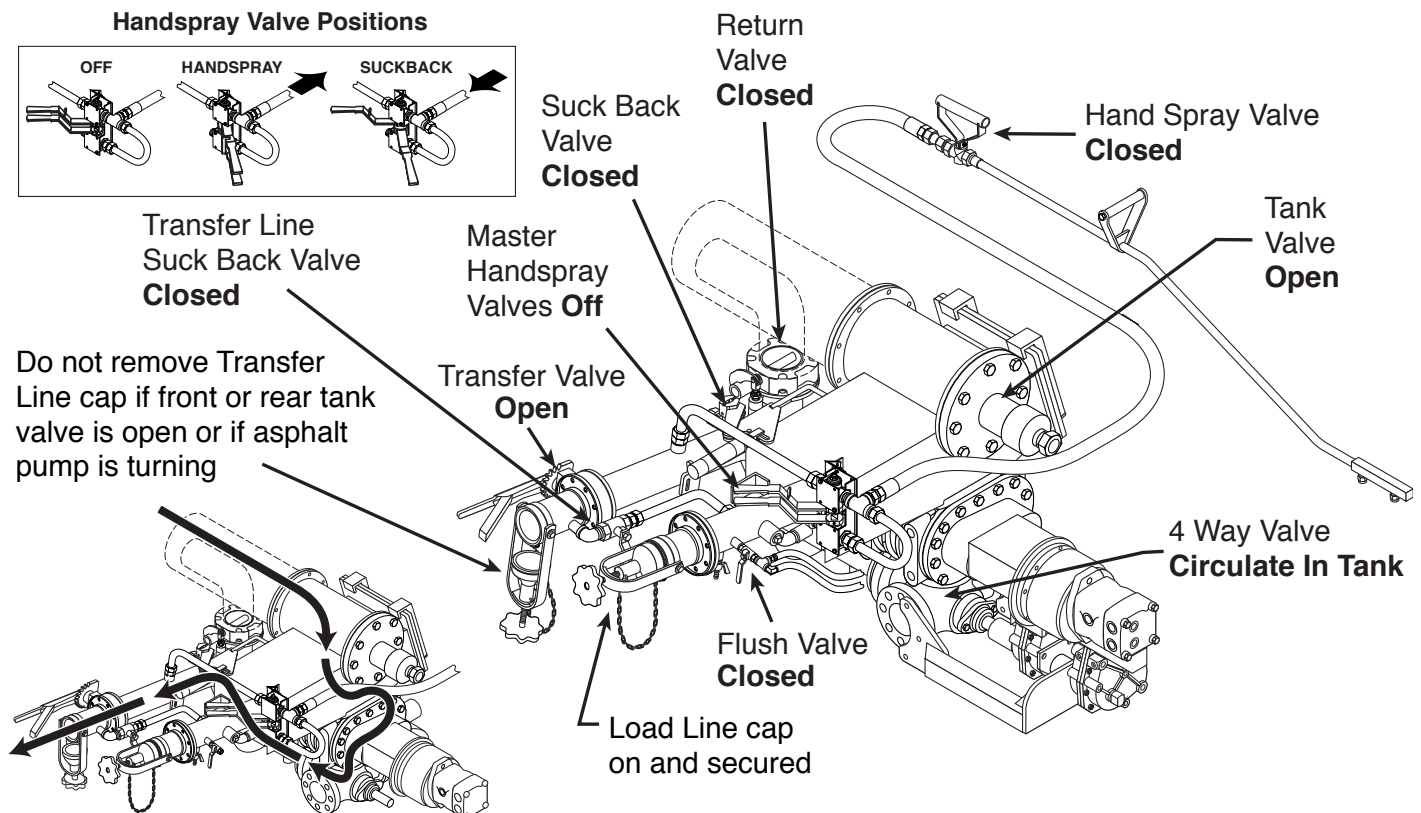

Figure 23. Valve Positions for Unload with Distributor Pump

5. Turn the Function knob to UNLOAD (the optional manual tank valve should be open).
6. Turn the EMERGENCY STOP switch ON.
7. Put the PUMP CONTROL to MANUAL.
8. Press START. Increase the PUMP SPEED knob so that the asphalt pump turns slowly.
9. After ensuring the flow between the Distributor and the storage tank is unobstructed, decrease the PUMP SPEED to zero.
10. Put the PUMP CONTROL to AUTO.
11. Press START. The pump will start turning at the desired rate.
12. When finished unloading, turn the Function knob to SUCK BACK (the optional manual tank valve should be closed).
13. Close the valve at the storage tank.
14. Close the transfer valve.
15. Open the transfer suck back valve.
16. Press START.
17. At the storage tank, carefully open the bleeder valve or break the hose connection until a strong vacuum is heard. It may be necessary to reduce the pump speed in order to overcome pump vacuum when breaking the hose connection. Elevating the hose above the storage tank connection will allow maximum drainage of the hose.
18. Disconnect the hose from the transfer line.
19. Replace the transfer line cap and secure.
20. Close the transfer suck back valve.
21. Flush the pump before quitting.

NOTE: The pump can be stopped and the automatic tank valve can be closed immediately at any time during operation by turning the EMERGENCY STOP switch OFF. Before turning the EMERGENCY STOP switch back ON, turn the PUMP SPEED to zero to prevent the pump from turning.

TRANSFER OPERATIONS

Refer to **Figure 24** for the following procedures.

1. Park the Distributor for transferring.
2. Set the truck parking brake.
3. The engine must be running and the optional transmission PTO must be engaged.
4. On the cab control panel, turn the POWER switch ON.

At the rear of the distributor:

Set or confirm the following:

- Tank valve **closed**
- Bar suck back valve(s) **closed**
- Master hand spray valve **closed**
- Transfer line suck back valve **closed**
- Transfer line valve **closed**
- Flush valve **closed**
- Load and transfer line caps are in place and secured.

At the rear control panel:

1. Turn the Function knob to TRANSFER (the optional manual tank valve should be closed).
2. Turn the EMERGENCY STOP ON.
3. Remove the transfer line cap.
4. Connect the transfer line to the storage tank through an asphalt hose.
5. Open the transfer valve.
6. Put the PUMP CONTROL switch in MANUAL.
7. Press START. Increase the PUMP SPEED that the asphalt pump turns slowly.
8. Remove the load line cap.
9. Connect the load line to the supply tank with an asphalt hose.
10. Open any valves on the storage tank between the asphalt hose and the tank.
11. Open the tank valve on the supply tank.
12. Decrease the PUMP SPEED to zero.
13. Put the PUMP CONTROL to AUTO.
14. Press START. The pump will start turning at the desired rate.
15. Close the tank valve on the supply tank when the desired amount of product is in the storage tank.

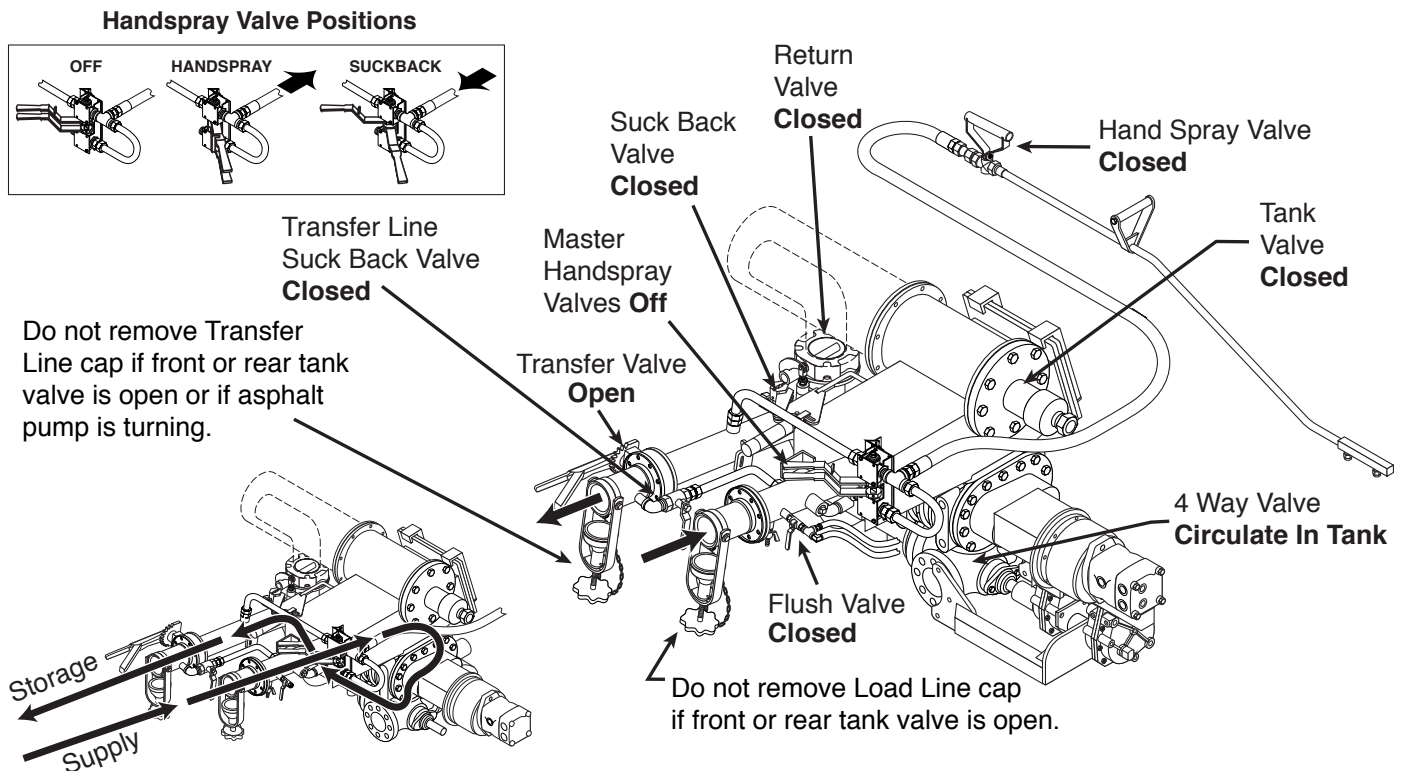

Figure 24. Valve Positions for Transfer

16. At the supply tank, carefully open the bleeder valve or break the hose connection until a strong vacuum is heard. It may be necessary to reduce the pump speed in order to overcome the pump vacuum when breaking the hose connection. Elevating the hose above the load line connection will allow maximum drainage of the hose.
17. Disconnect the hose from the load line.
18. Replace the load line cap and secure.
19. Put the PUMP CONTROL to MANUAL to stop the pump and then put it back to AUTO.
20. Close the valve at the storage tank.
21. Close the transfer valve.
22. Turn the Function knob to SUCK BACK (the optional manual tank valve should be closed).
23. Open the transfer suck back valve.
24. Press START.
25. At the storage tank, carefully open the bleeder valve or break the hose connection until a strong vacuum is heard. It may be necessary to reduce the pump speed in order to overcome the pump vacuum when breaking the hose connection. Elevating the hose above the load line connection will allow maximum drainage of the hose.
26. Disconnect the hose from the transfer line.
27. Replace transfer line cap and secure.

28. Close the transfer line suck back valve.
29. It may be necessary to flush the pump before doing the next step.
30. To stop the pump in MANUAL control select AUTO control. To stop the pump in AUTO control with the PUMP SPEED knob fully counter clockwise select MANUAL control.

NOTE: The pump can be stopped and the automatic tank valve can be closed immediately at any time during operation by turning the EMERGENCY STOP switch OFF. Before turning the EMERGENCY STOP switch back ON, turn the PUMP SPEED to zero to prevent the pump from turning.



WARNING

To prevent burns, always wear insulated gloves when handling spray bar sections or hoses.



WARNING

Suckback of the storage tank line will put material into the tank and could cause an explosion if the tank has not been fully cleaned of emulsion material.

Heating Product in Distributors

Heating Asphalt w/ Propane Burners



IMPORTANT

Circulating the asphalt in the tank while heating is recommended for faster heating and reduced carbon formation on the flues. Only when the asphalt pump is *Frozen* is it acceptable to operate the burners without circulating asphalt in the tank. However, if the asphalt pump is frozen, carefully apply heat to the pump and start circulating the material as soon as possible.



WARNING

1. Residual fuel in Propane burners will support a flame for several minutes after the fuel flow has been shut off. After using Propane burners, confirm that all flame has been extinguished before attempting any operation that could release flammable vapors. Failure to ensure that the flame is completely extinguished could result in an explosion or fire that can cause injury or death.
2. Position unit broadside to wind whenever possible to prevent volatile fumes from drifting toward burners
3. Flues **MUST** be covered by a minimum of 6 inches (150mm) of material when the burners are in operation.
4. Do not remove material from tank in any manner when the burners are in operation.
5. Do not drive unit when burners are operating.
6. Do not operate burners if tank is damaged or leaking.
7. When burners go out, allow flues to ventilate for several minutes before relighting burners.
8. Do not heat material beyond the manufacturer's recommended temperature.
9. Do not heat material over 200°F (95°C) if moisture is present in tank.
10. To prevent possible burns from material overflow, allow sufficient space in tank for expansion of material when heating.



WARNING (cont)

11. Always shut off burners using the main shutoff valve on the supply tank.
12. To prevent possible burns, always use a torch to light the burners. never attempt to light the burners with a match or pocket lighter.
13. Light inside burner first. Do not reach across a lighted burner to relight inside burner.
14. Check overflow tube for restrictions.
15. When heating, temperatures within the tank can vary. Shut the burners off when the thermometer reaches a reading 10°F lower than the desired temperature. Continue to circulate & monitor temperature until temperature stabilizes. Add remaining heat by operating burners for short periods, monitoring stabilized temperature after each period.
16. Always have a dry chemical type fire extinguisher available and in good condition.



IMPORTANT

Calibration of thermometers should be verified to be within + 2% of full scale reading annually.

Certification can be accomplished by a qualified laboratory or by comparing stabilized dial readings to the pencil thermometer reading. Replace any thermometer that does not meet the +2% accuracy requirement.

Propane Requirements

Use only liquid withdrawal type supply tanks for your propane burners.

Two types of propane supply tanks are available: tanks for liquid type burners and tanks for vapor type burners. The propane burners on your Etnyre Distributor require a supply tank for liquid type burners. Liquid type burners will operate from a vapor withdrawal tank, however the amount of heat delivered will be dramatically reduced, and the life of the burner will be shortened.

PROPANE BURNER OPERATION

Manual Ignition Control

The main shutoff valve and bleeder valves are closed by turning their knobs clockwise. The bleeder valves are equipped with a bypass orifice to prevent trapping pressure in the system when they are closed which means that they do not completely shut off propane to the burners. The upper burner can be shut off completely through the upper burner shutoff valve. The upper burner shutoff valve is closed by turning the handle perpendicular to the valve. The safety valve located in the supply line between the tank and the regulator should be kept clean and free from debris so that it can relieve if excessive pressure ever develops in the line.

A good rule of thumb for setting the pressure regulator is based on the size of the asphalt tank. Experimentation with pressure settings will allow you to determine the most efficient setting. Increasing pressure will increase propane usage while decrease heating time.

- 15 PSI (1000-1250 gal)
- 20 PSI (1500-1750 gal)
- 25 PSI (2000-2250 gal)
- 30 PSI (2250-2500 gal)
- 40 PSI (2750+ gal).

The burners are vaporizing burners which means that they convert liquid propane to vapor in the coils of the burner. When the burners are operating correctly the system will frost over from the regulator to the first coil of the burner. If frost does not form it is an indication that the burners are operating on vapor instead of liquid. This condition must be corrected immediately to prevent damage to the burners. If frost does form but then the flame diminishes and the frost melts it is an indication that there is moisture in the tank. Moisture in the tank will freeze in the system. Propane suppliers can add an antifreeze agent to eliminate moisture.



WARNING

If a torch is not lit for the lower burner before opening the main shutoff there is a potential of flashback when lighting the burner as the flue will fill with gas.

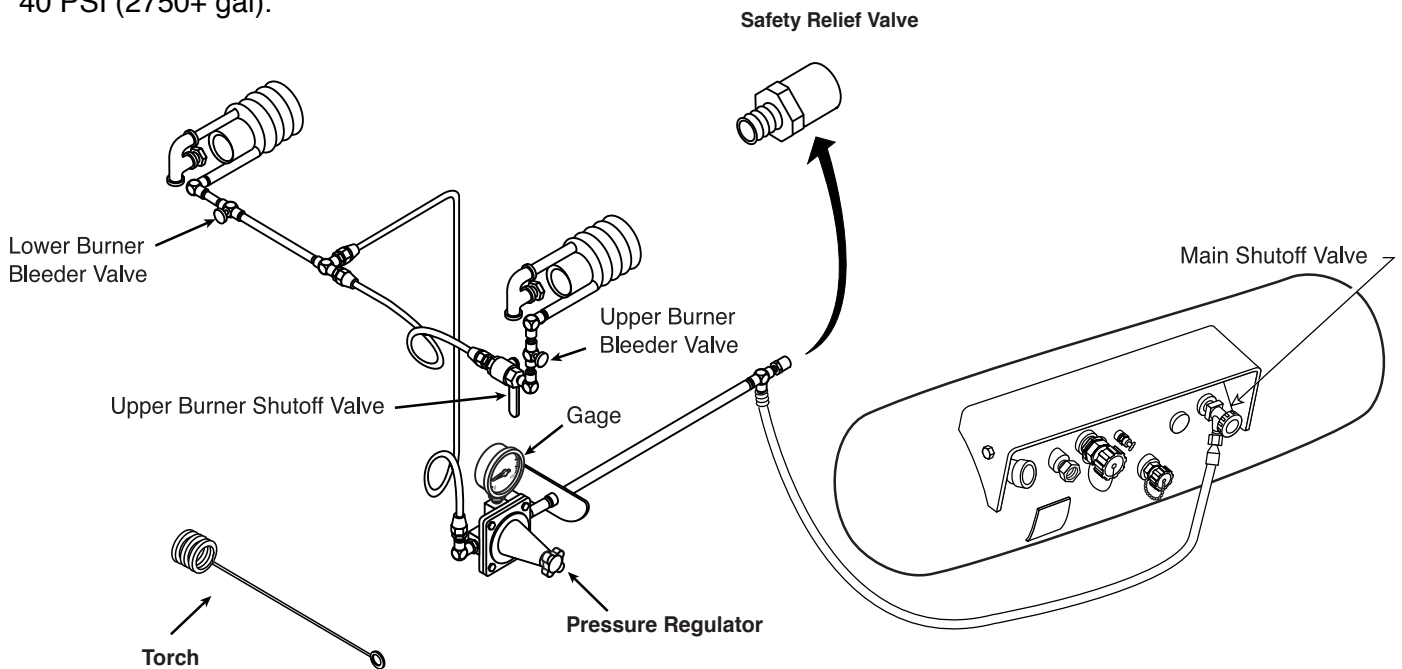

Figure 25 Manual Ignition Control System

PROPANE BURNER OPERATION

Manual Ignition Control (cont)

1. Ensure that there is at least 6 inches (152mm) of material covering the flue that will be used for heating before proceeding.
2. Open the exhaust stack damper or cover.
3. The supply tank connection must be for liquid withdrawal.
4. Close the valves at the burners.
5. Ignite burner torch and place in lower flue.
6. Open the supply valve slowly.
7. Check for LP leaks, repair leaks before proceeding.
8. Set the LP pressure, see operation manual for pressure recommendation.
9. Circulate material in the tank at 150 GPM (568 LPM)
10. With the lower burner ignited remove the burner torch, extinguish burner torch or insert in upper flue if also using upper burner
11. Adjust lower burner valve to increase flame.
12. When using upper burner, first open upper burner shut off valve, after ignition remove and extinguish burner torch, finally adjust upper burner valve to increase flame.
13. Do not heat the material higher than material supplier's recommendation.
14. When shutting down, close the supply valve before closing the valves at the burners to exhaust all LP.
15. When the burner is off, close the exhaust stack damper or cover to prevent heat loss.

Ignition and Out Fire Control

The safety valve located in the supply line between the tank and the regulator should be kept clean and free from debris so that it can relieve if excessive pressure ever develops in the line. ***There is a different safety valve located after the regulator that should also be kept clean and free from debris.***

A good rule of thumb for setting the pressure regulator is based on the size of the asphalt tank. Experimentation with pressure settings will allow you to determine the most efficient setting. Increasing pressure will increase propane usage while decreasing heating time.

- 15 PSI (1000-1250 gal)
- 20 PSI (1500-1750 gal)
- 25 PSI (2000-2250 gal)
- 30 PSI (2250-2500 gal)
- 40 PSI (2750+ gal).

The burners are vaporizing burners which means that they convert liquid propane to vapor in the coils of the burner. When the burners are operating correctly the system will frost over from the regulator to the first coil of the burner. If frost does not form it is an indication that the burners are operating on vapor instead of liquid.

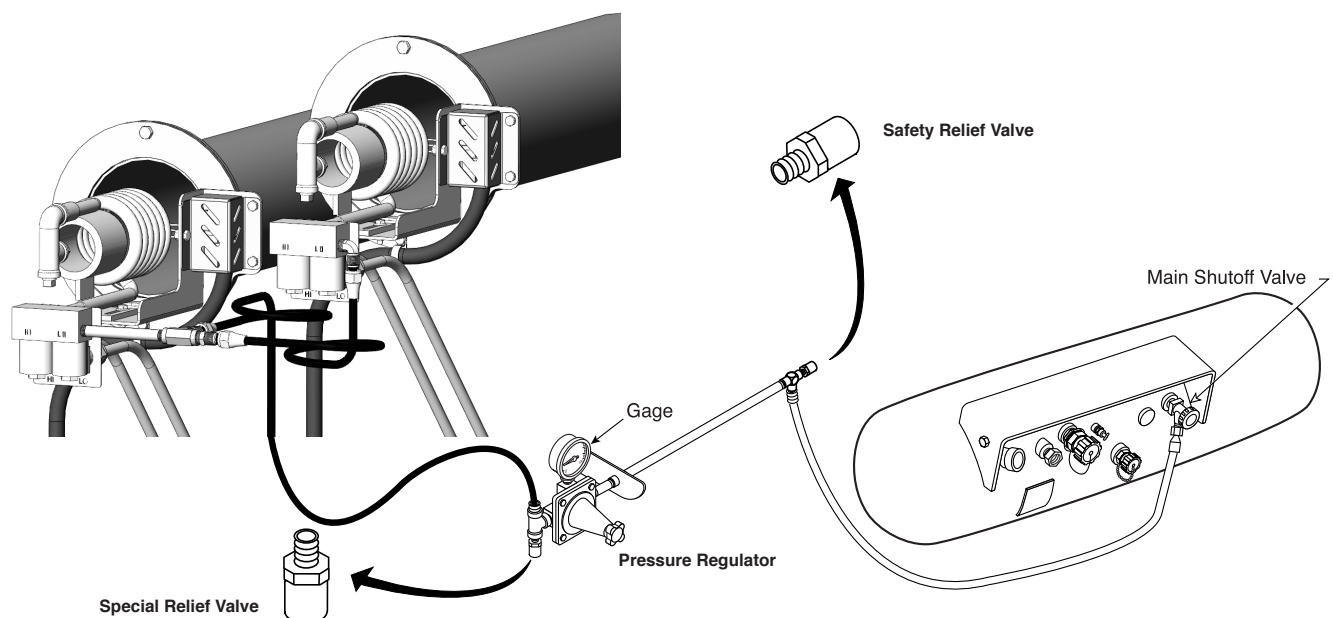

Figure 26. Ignition & Out Fire Control System

This condition must be corrected immediately to prevent damage to the burners. If frost does form but then the flame diminishes and the frost melts it is an indication that there is moisture in the tank. Moisture in the tank will freeze in the system. Propane suppliers can add an antifreeze agent to eliminate moisture.

If the Power switch or Emergency Stop switch is turned off during burner operation the burner(s) will turn off and will not turn back on with out cycling the burner switch(s).

If the distributor is driven faster than 300 FPM or if Hand Spray, Unload, Transfer, Spray, Flush or Aux is selected during burner operation the burner(s) will turn off and will not turn back on with out cycling the burner switch(s).

Without the optional thermostatic controls installed, 999 will be displayed in place of the actual temperature and the burners will only be allowed to operate for 15 minutes without further operator input. The burner(s) will automatically shutdown if the built in timer is allowed to expire. The timer can be reset by the operator at anytime through the Timer Reset switch. During the last 5 minutes of the timer interval the message, BURNER TIMER ENDING, will be displayed on the screen. The burner(s) will not turn back on without cycling the burner switch(s).

If a burner fails to ignite it will go into Lockout and will not turn back on without cycling the burner switch. The controller will allow four tries for ignition before going to Lockout. Each try for ignition will be 3 seconds on for the electrode and the LO flow solenoid valve followed by being off for 6 seconds. Once a flame is sensed the tries for ignition will be reset.



WARNING

Do not attempt to manually light the burners if they do not automatically light. There is a potential for flashback when lighting the burners as the flues may have filled with gas.

1. Ensure that there is at least 6 inches (152mm) of material covering the flue that will be used for heating before proceeding.
2. Open the exhaust stack damper or cover.
3. The supply tank connection must be for liquid withdrawal.
4. Open the supply valve slowly.
5. Check for LP leaks, repair leaks before proceeding.
6. Set the LP pressure, see operation manual for pressure recommendation.
7. Circulate material in the tank at 150 GPM (568 LPM)
8. Turn the burner switch on that will be used for heating.
9. Do not heat the material higher than material supplier's recommendation.
10. When shutting down, close the supply valve and then turn off the burner switch to exhaust all LP.
11. When the burner is off, close the exhaust stack damper or cover to prevent heat loss.

Controller LED Fault

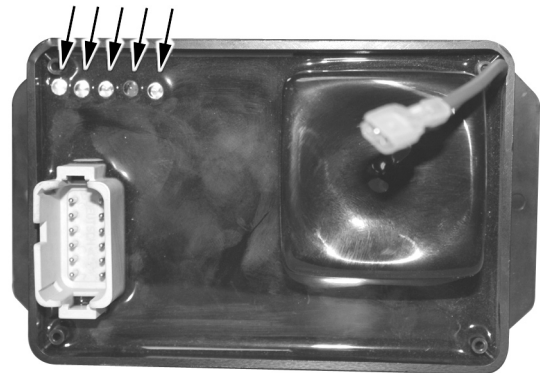

Order of LEDs

POWER (GREEN) = ON WHEN POWER APPLIED TO CONTROL

HI VALVE (GREEN) = ON WHEN HI VALVE OUTPUT ON

SPARK (GREEN) = ON WHEN SPARK OUTPUT IS PULSING

FLAME (RED) = ON WHEN COMMAND APPLIED, NO FAULTS AND FLAME DETECTED

LO VALVE (GREEN) = ON WHEN LO VALVE OUTPUT ON

Fault flash patterns of Red LED

(1/2 SECOND FLASH, 2 SECOND PAUSE BETWEEN MULTIPLE FAULTS)

1 FLASH = HI VALVE OUTPUT SHORTED TO 12V

2 FLASHES = HI VALVE OUTPUT OVER CURRENT OR SHORTED TO GND

3 FLASHES = LO VALVE OUTPUT SHORTED TO 12V

4 FLASHES = LO VALVE OUTPUT OVER CURRENT OR SHORTED TO GND

5 FLASHES = LOCKOUT, FAILURE TO IGNITE

6 FLASHES = FLAME FAULT, FLAME PRESENT AT START UP

FAULTS CLEARED WITH COMMAND INPUT

PROPANE BURNER OPERATION

Thermostatic Control

After setting the target temperature in the display the burners can be operated following the instructions and precautions for Operation with Ignition and Out Fire Control. The target temperature, which can be changed in 5 degree increments, is reset to 95°F or 35°C when the system power is turned on. The timer will allow 15 minute heating intervals if temperature sender is out of range, 999 is displayed in place of the actual temperature, or 60 minute intervals otherwise.

The timer can be reset by the operator at any time through the Timer Reset switch. During the last 5 minutes of the timer interval the message, BURNER TIMER ENDING, will be displayed on the screen. The burner(s) will also turn off if the temperature sender goes out of range during burner operation. In all conditions, the burner(s) will not turn back on without cycling the burner switch(s).



WARNING

The thermostatic control temperature is measured at the bottom of the tank.

The temperature in the bottom of the tank may be significantly colder than the top of the tank or around the flues.

Manually monitor the tank temperature carefully to avoid overheating if initially the load could not be circulated or was known to be cold or frozen.

Heating Product in Distributors

Heating Asphalt w/ Fuel Oil Burners



IMPORTANT

Circulating the asphalt in the tank while heating is recommended for faster heating and reduced carbon formation on the flues. Only when the asphalt pump is *Frozen* is it acceptable to operate the burners without circulating asphalt in the tank. However, if the asphalt pump is frozen, carefully apply heat to the pump and start circulating the material as soon as possible.



IMPORTANT

Calibration of thermometers should be verified to be within + 2% of full scale reading annually.

Certification can be accomplished by a qualified laboratory or by comparing stabilized dial readings to the pencil thermometer reading. Replace any thermometer that does not meet the +2% accuracy requirement.



WARNING

1. Position unit broadside to wind whenever possible to prevent volatile fumes from drifting toward burners
2. Flues **MUST** be covered by a minimum of 6 inches (150mm) of material when the burners are in operation.
3. Do not remove material from tank in any manner when the burners are in operation.
4. Do not drive unit when burners are operating.
5. Do not operate burners if tank is damaged or leaking.
6. When burners go out, allow flues to ventilate for several minutes before relighting burners.
7. Do not heat material beyond the manufacturer's recommended temperature.
8. Do not heat material over 200°F (95°C) if moisture is present in tank.
9. To prevent possible burns from material overflow, allow sufficient space in tank for expansion of material when heating.
10. Check overflow tube for restrictions.
11. There must be at least 6 inches of material covering the entire length of the upper flue before the second burner can be lit.
12. When heating, temperatures within the tank can vary. Shut the burners off when the thermometer reaches a reading 10°F lower than the desired temperature. Continue to circulate & monitor temperature until temperature stabilizes. Add remaining heat by operating burners for short periods, monitoring stabilized temperature after each period.
13. Always have a dry chemical type fire extinguisher available and in good condition.

FUEL OIL BURNER OPERATION

Ignition and Out Fire Control

The air inlet screen on the burner needs to be kept clean and free of debris in order for efficient operation.

If the Power switch or Emergency Stop switch is turned off during burner operation the burner(s) will turn off and will not turn back on without cycling the burner switch(s).

If the distributor is driven faster than 300 FPM or if Hand Spray, Unload, Transfer, Spray, Flush or Aux is selected during burner operation the burner(s) will turn off and will not turn back on without cycling the burner switch(s).

Without the optional thermostatic controls installed, 999 will be displayed in place of the actual temperature and the burners will only be allowed to operate for 15 minutes without further operator input. The burner(s) will automatically shutdown if the built in timer is allowed to expire. The timer can be reset by the operator at anytime through the Timer Reset switch.

During the last 5 minutes of the timer interval the message, BURNER TIMER ENDING, will be displayed on the screen. The burner(s) will not turn back on without cycling the burner switch(s).

1. Ensure that there is at least 6 inches (152mm) of material covering the flue that will be used for heating before proceeding.
2. Open the exhaust stack damper or cover.
3. Circulate material in the tank at 150 GPM (568 LPM).
4. Turn the burner switch on that will be used for heating.
5. Do not heat the material higher than the material supplier's recommendation.
6. To shut down, turn the burner switch off.
7. When the burner is off, close the exhaust stack damper or cover to prevent heat loss.

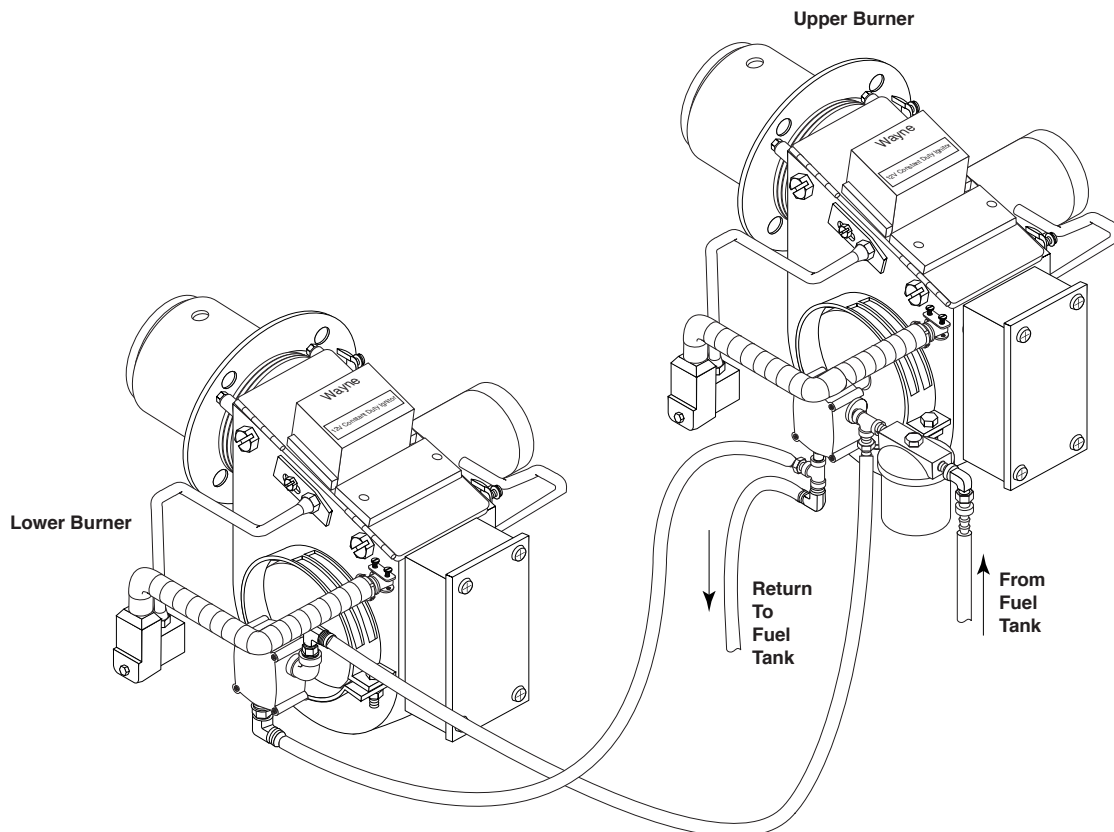
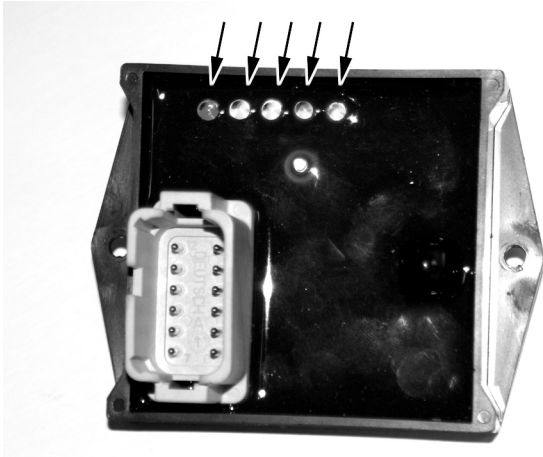

Figure 27. Fuel Oil Burner System

FUEL OIL BURNER OPERATION

Controller LED Fault



Order of LEDs

FLAME (RED) = ON WHEN COMMAND APPLIED, NO FAULTS AND FLAME DETECTED BY CAD CELL

POWER (GREEN) = ON WHEN POWER APPLIED TO CONTROL

MOTOR (GREEN) = ON WHEN MOTOR OUTPUT ON

VALVE (GREEN) = ON WHEN VALVE OUTPUT ON

IGNITOR (GREEN) = ON WHEN IGNITOR OUTPUT ON

Fault flash patterns of Red LED

(1/2 SECOND FLASH, 2 SECOND PAUSE BETWEEN MULTIPLE FAULTS)

1 FLASH = CAD > 20K ON POWER UP

2 FLASHES = IGNITOR OUTPUT SHORTED TO 12V

3 FLASHES = VALVE OUTPUT SHORTED TO 12V

4 FLASHES = MOTOR OUTPUT SHORTED TO 12V

5 FLASHES = NO IGNITION DETECTED AFTER 15 SECONDS THROUGH CAD CELL

6 FLASHES = VALVE OUTPUT OVER CURRENT OR SHORTED TO GND

7 FLASHES = IGNITOR OUTPUT OVER CURRENT OR SHORTED TO GND

8 FLASHES = MOTOR OUTPUT OVER CURRENT OR SHORTED TO GND

FAULTS CLEARED WITH COMMAND INPUT

Thermostatic Control

After setting the target temperature in the display the burners can be operated following the instructions and precautions for Operation with Ignition and Out Fire Control. The target temperature, which can be changed in 5 degree increments, is reset to 95°F or 35°C when the system power is turned on. The timer will allow 15 minute heating intervals if temperature sender is out of range, 999 is displayed in place of the actual temperature, or 60 minute intervals otherwise. The timer can be reset by the operator at anytime through the Timer Reset switch. During the last 5 minutes of the timer interval, the message BURNER TIMER ENDING will be displayed on the screen. The burner(s) will also turn off if the temperature sender goes out of range during burner operation. In all conditions, the burner(s) will not turn back on without cycling the burner switch(s).



NOTE

1. Read and understand the detailed instructions in the operation manual.
2. Ensure that there is at least 6 inches (152 mm) of material covering the flue that will be used for heating before proceeding.
3. Open the exhaust stack damper or cover.
4. Circulate material in the tank at 150 GPM (568 LPM).
5. Turn the burner switch on that will be used for heating.
6. Do not heat the material higher than material supplier's recommendation.
7. To shut down, turn the burner switch off.
8. When the burner is off, close the exhaust stack damper or cover to prevent heat loss.

Troubleshooting

Problem	Cause	Remedy
Spray Fogs	Pump speed too fast for size of nozzle.	Lower pump speed or change nozzles.
Spray Streaks	Pump speed too slow.	Increase pump speed.
	Nozzles not at proper angle.	Adjust angle of nozzles.
	Spray bar at improper height above ground.	Adjust spray bar height.
	Material temperature too low.	Heat material to correct temperature.
Spray Lacks Pressure	Pump speed too slow.	Adjust pump speed.
	One or more control valves in incorrect position, not fully opened or closed, or leaking.	Check position of all control valves. Be sure all valves are fully opened or closed. Repair leaking valves as necessary.
	Suction strainer plugged.	Clean suction strainer.
All Nozzles Do Not Cut Off Spray	Contaminant stuck in spray valve(s). Spray valve o-rings damaged or worn. Tack Coat pressure too high.	Disassemble spray valve and clean. Replace spray valve o-rings. Verify Tack Coat pressure relief is set to 20 PSI.
Pump Will Not Turn Or Turns Slowly	Material in tank or pump below pumping temperature.	Heat material to proper pump temperature.
	Air leak in suction line from reservoir to filter to inlet of charge pump.	Locate and repair leak.
	Hydraulic system pressure low.	Raise pressure.
	Low oil in hydraulic reservoir.	Add hydraulic oil to correct level.
	Spray bar valves set improperly.	Correct spray bar valve settings.
	Defective Hyd. motor.	Check for excessive case drain in motor.
Hydraulic Oil Overheats	Material in tank or pump below pumping temperature.	Heat material to proper pump temperature.
	Air leak in suction line from reservoir to filter to inlet of charge pump.	Locate and repair leak.
	Low oil in hydraulic reservoir.	Add hydraulic oil to correct level.
	Spray bar valves set improperly.	Correct spray bar valve settings.
Spray Bar Supply Tube Swivel Joints Leak	Swivel joint O-ring is loose.	Replace swivel joint O-ring.
Application Rate Varies	Quantity of material in tank not being measured accurately.	Use Etnyre measuring stick for accurate readings. Be sure tank is level when measuring.
	Suction strainer plugged.	Clean suction strainer regularly.
	Hydrostatic controls not firmly positioned.	Ensure that all controls are firmly locked in place.
	Suck back valves not fully closed.	Ensure valve is closed.

Troubleshooting

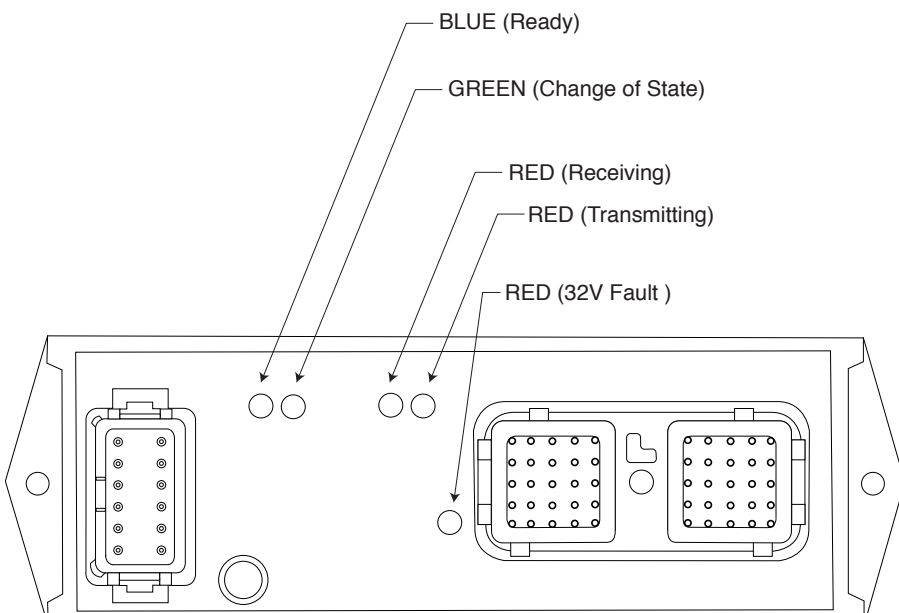
Switch Input Module in Cab Control Box	
Problem	Cause
RED (32V Fault)	When Short or Overcurrent Occurs, Cycle Power
RED (Can Transmitting)	Flashing = Transmitting Off = No Activity
RED (Can Receiving)	Currently Not Used
GREEN (Change of State)	Flashes When The Voltage Changes On Any Of the 56 Inputs
BLUE (Ready)	Flashes When Unit Is Ready
 <p>The diagram shows a rectangular control module with two large multi-pin connectors on the left and right sides. Five LED indicators are shown as small circles above the module. Arrows point from labels to these LEDs: BLUE (Ready) points to the leftmost LED; GREEN (Change of State) points to the second LED from the left; RED (Receiving) points to the third LED from the left; RED (Transmitting) points to the fourth LED from the left; and RED (32V Fault) points to the rightmost LED. There is also a small circular indicator located below the left connector.</p>	

Maintenance

Gun Assembly

NOTE: Before installing gun assembly, check that blower wheel turns freely and that all set screws are tightened securely.

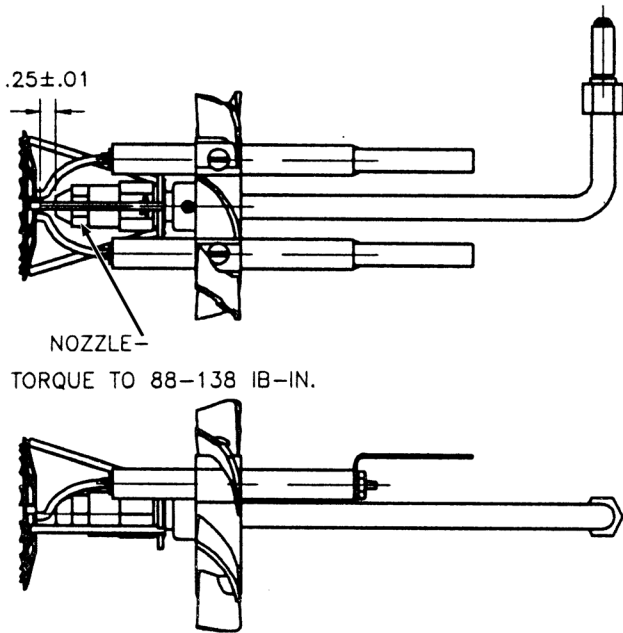

Figure 28. Gun Assembly

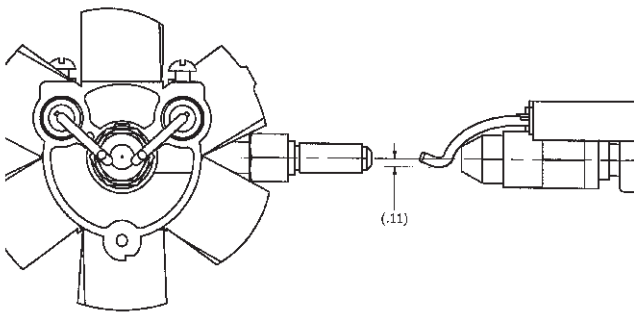

Figure 29. Right Hand / Left Hand Electrodes

Electrode Settings

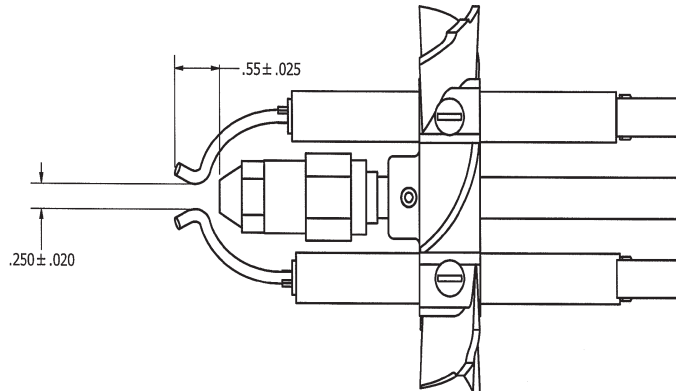

Figure 30. Electrode Setting

WARNING

To prevent an explosion or fire hazard, keep area free of sparks or open flames when testing burners.

Check Ignition Transformer Spark

1. Turn on power switch in rear control box.
2. Turn the BURNER switches on.
3. Hold an insulated screwdriver touching one of the springs and approximately 3/4 inches above the other spring on the transformer. It should be possible to jump a spark across the 3/4 inch gap between the spring and the screwdriver. If unable to generate a blue spark across this gap, check the voltage at terminal spades of the 12 volt ignition control box. Voltage must be 12 VDC minimum. If voltage is incorrect or not present, check ground wiring.
4. Reposition ignition transformer and secure to burner housing.

Fire Burners

1. Ensure that fuel oil pressure is 150 PSIG.
2. Turn the burner switch on.
3. Run the burner for 15 seconds maximum after lighting, then shut down.



WARNING

To prevent an explosion or fire hazard, flues must be covered by minimum 6 inches of material when burners are in operation. When testing burners, do not run burners for more than 15 seconds if tank is empty.

Replacing Speed Pickup

1. Loosen locknut and remove old speed pickup.
2. Turn in the new speed pickup clockwise by hand until the bottom end gently touches the internal speed ring.
3. Back it out counter clockwise 1/2 to 3/4 turn.
4. Using a 1/2 inch wrench to hold the speed pickup, torque the locknut to 10 lb-ft (13 Nm) with an 11/16 inch wrench.

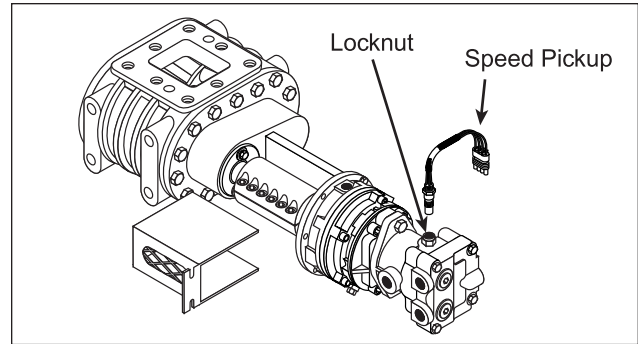

Figure 31. Hydraulic Motor

Servicing the Etnyre P-15 Pump

Vacuum Check

1. Flush pump with 3 quarts of diesel fuel through fill line.
2. Set controls for loading operation.
3. Install vacuum gauge in fill line cap.
4. Operate pump at 140 GPM on pump tachometer. A vacuum reading of less than 5 inches Hg. (inches of mercury) after 2 minutes of operation indicates a vacuum leak or a worn pump.

Pump Disassembly And Inspection

1. Remove 20 capscrews from perimeter of pump end plate (see **Figure 32**).
2. Install two capscrews in the threaded holes near the outer edge of the end plate at approximately the 5 o'clock and 11 o'clock positions. Tighten the capscrews evenly to force the endplate away from the pump body.
3. Remove the endplate, impeller shafts and impellers (gears) as an assembly.
4. Clean the interior of the pump case. Slide your fingers across the interior surfaces of the case. If a narrow raised area can be felt midway between the front and the rear of the case, the entire pump should be replaced.
5. If there is no raised area, measure the bore of the case at its widest point horizontally (side-to-side). This measurement must not exceed 9.910 inches.

6. Next, measure the case bore vertically at a point 2.8 inches from each side. The vertical measurement must not exceed 5.660 inches. If any bore measurements exceed these limits, the entire pump must be replaced.
7. If inspection indicates the pump case is acceptable, measure the outside diameter of the impeller gears. Measure the impeller gears from tooth point to tooth point on teeth directly opposite each other. The minimum outside diameter of the gears should be 5.635 inches. The minimum length of the gears should be 3.628 inches.
8. If any impeller gear is undersize, the entire four-gear set must be replaced.
9. End plate gasket thickness should be 0.014 to 0.016 inches.
10. Divider plate thickness should be 0.127 to 0.128 inches.

Impeller Installation And Pump Assembly

Each impeller gear set uses a series of dots on the gear faces to indicate position of the gears within the pump. Refer to **Figure 32** for proper positioning of the gears. The dots must face away from the divider plate (towards the ends of the pump). Install the impellers in numerical order.

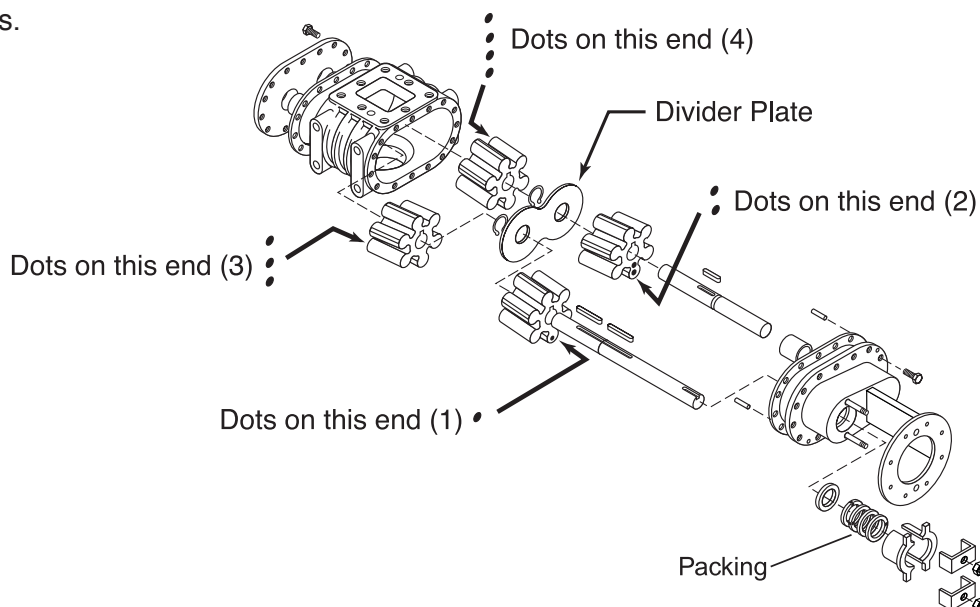

Figure 32. Etnyre Asphalt Pump

General Fuel Data and Heating Terminology

Fuel Data

Fuel	Weight Per Gallon	BTU Content
#2 Fuel Oil	7.49 lbs	144,300 per gallon
Propane	4.20 lbs.	91,500 per gallon

Approximate Burner Fuel Consumption

Fuel Oil

429,000 BTU

2.97 GPH per burner

(144,300 BTU per gallon)

Propane

1,130,000 BTU @ 40 PSI

12.34 GPH per burner

(91,500 BTU per gallon)

Heating Terminology

Flash Point (Open Cup)

The temperature at which a flammable liquid in an open container emits vapor that will flash when exposed to a direct flame. This temperature is lower than required for the liquid mass to ignite.

Closed Flash Point

The temperature at which a flammable liquid in a closed container emits a vapor that will flash when exposed to a direct flame. This temperature is lower than required for the liquid mass to ignite. The closed flash point is generally 30° F lower than the open cup flash point.

Fire Point

The temperature at which a flammable liquid emits a vapor at a rate that will continue to burn after it has flashed.

Ignition Temperature (Kindling Temperature)

The lowest temperature at which a combustible material will continue to burn once ignited.

Convection

Heat transfer by a flow of a liquid or gas over a solid material. Example: Flues in asphalt tank are heated from hot gases passing through them, or, heat transfer coils in tank are heated from steam or hot oil passing through them.

Conduction

Heat transfer through a solid mass by direct molecular contact. Example: Heat applied only to one end of a metal rod will be transferred throughout the entire body by molecular transfer.

Hydraulic Fluid Requirements

General Information

The ability of a hydrostatic transmission to maintain desired performance for the expected life depends on the quality of fluid being circulated in the units. Fluid quality can be measured in three general categories: lubricity, contaminants, and temperature. Obtaining satisfactory values in these three areas depends on the fluid and the circuit in which it is used.

Etnyre field service experience indicates that most transmission failures result from a breakdown of fluid quality. Primary causes are solid particle contamination and overheating. Water or oil in the fluids are also significant contributors. These problems are usually the result of poor maintenance. Sometimes fluid selection can lessen the impact of unusual environmental factors.

Hydraulic Fluid Requirements

The catalog ratings and performance data are based on operating with good quality petroleum based fluids. Premium hydraulic fluids containing high quality rust, oxidation and foam inhibitors are required. These include premium turbine oils, API CD engine oils per SAE J183, M2C33F or G automatic transmission fluid (Type F), power shift transmission fluids meeting Allison® C-3 or Caterpillar® TO-2, and certain specialty agricultural tractor fluids.

Although fluids containing anti-wear additives are not necessary for satisfactory performance, when used, the fluids must possess good thermal and hydrolytic stability to prevent wear, erosion and corrosion of the internal components.

Where water contamination is likely due to condensation, operation in a damp environment or frequent splashing, a fluid with outstanding hydrolytic stability is recommended. Consult the Etnyre Service Department for recommendations for these fluids. Avoiding the use of Dexron® II transmission fluids which *do not* meet Allison C-3 specification is recommended.

Viscosity & Temperature Requirements

The fluid must have sufficient viscosity to maintain an oil film at the bearing surfaces. This depends on fluid selection and on operating temperature. Recommended viscosity for best life and efficiency, and minimum for intermittent and continuous operation is listed below.

Fluid Viscosity Limits For Petroleum Based Fluids	
Maximum Continuous SUS (cSt)	500 (110)
Optimum Viscosity SUS (cSt)	70 (13)
Minimum Continuous SUS (cSt)	55 (9.0)
Minimum Intermittent SUS (cSt)	47 (6.4)

Viscosity index improved (multi-viscosity) fluids may noticeably shear down in service when used in hydrostatic transmissions. This will lower the operating viscosity below the originally specified value. The lowest expected viscosity must be used when selecting fluids. Consult your fluid supplier for details on viscosity sheardown.

Fluid temperature affects the viscosity of the fluid and resulting lubricity and film thickness. High temperatures can also limit seal life, as most nonmetallic seals are adversely affected by use at elevated temperatures. Also, fluids may break down or oxidize at high temperatures, reducing their lubricity and the resulting life of the unit. Cavitation is more likely at high temperature. Recommended limits for operating temperatures are tabulated below.

Fluid Temperature Limits For Petroleum Based Fluids	
Continuous Limit	180°F
Intermittent Limit	220°F

These temperature limits apply at the hottest point in the transmission, which is normally the motor case drain.

Heat problems sometimes occur because of problems with one of the circuit components. A partially stuck relief valve will heat up the oil rapidly. Circuit components that have developed high internal leakage rates will contribute to heat generation.

Contamination Levels

Clean fluid implies the absence of impurities such as solid particles, water and air. Contamination control includes proper design, installation, and maintenance of hydraulic components.

The reservoir is designed to limit entry of contamination during servicing and operation. A

sealed reservoir with a low pressure relief valve reduces the introduction of contaminants while maintaining inlet and case drain pressures below the maximum recommended.

The purpose of the filter in a system is to clean the oil at initial start up and to maintain acceptable levels of particle contaminants as they are ingested or generated during operation of the system. Filtration is a matter of controlling the particle sizes and their respective quantities to appropriate levels so as to avoid degradation of the system components and thereby assure the desired life.

Fluid contaminant profile requirements for Etnyre hydraulic units have been determined empirically based on measuring fluid quality in successful application, and in laboratory tests designed to evaluate hydraulic unit contaminant sensitivity. General contaminant levels have been developed based on this experience and are shown in Figure 32.

Acceptable contamination levels at machine start up for the system loop should be equal to or better than Curve D. The machine may be exercised to 500 psi but should not be worked (pressure over 500 psi) until the oil cleanliness meets or exceeds Curve C.

The machine should clean up during a relatively short period of normal operation to meet the oil cleanliness level of Curve A or Curve B. A system that meets Curve A will provide the user with a longer trouble-free operating life than one that meets Curve B. The Curve A cleanliness level should be met in systems exceeding the continuous pressure limit for 1000 hours/years machine use.

Some control valves may require better contamination limits than specified in Figure 32. Controls with small area screens or low force level values may be susceptible to malfunction from contamination.

The contamination sensitivity of components generally increases with higher pressure, temperature or speed. A better fluid contaminant profile may be required for systems which operate near the extremes of their ratings. Short life or infrequent operation requirements may increase allowable contaminants.

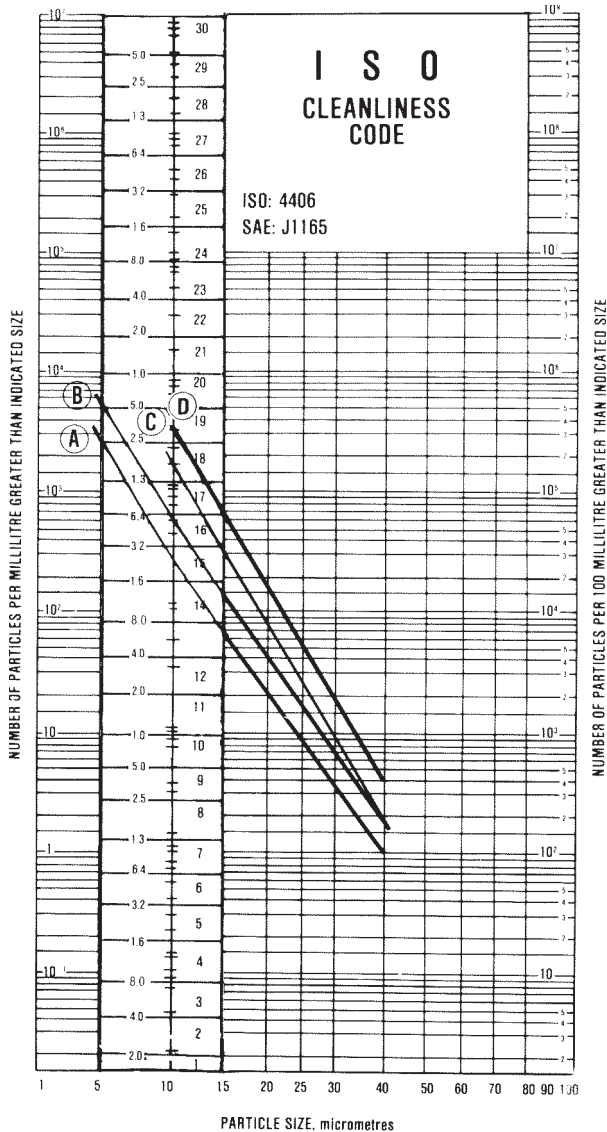

Curve A Desired limit for longer life (3500 PSI continuous system pressure)	Curve C Limit at machine ship and new fluid added to transmission
Curve B Continuous operating limit (2000 PSI continuous pressure) system	Curve D Limit at machine start up

Figure 33. Fluid Cleanliness Chart

The selection of a filter depends on a number of factors including the contaminant ingress rate, the generation of contaminants in the system, the required fluid cleanliness, and the desired maintenance interval. Filters are selected to meet the above requirements using rating parameters of efficiency and capacity.

Filter efficiency may be measured with a Beta ratio. For simple closed circuit transmissions with controlled reservoir ingress, a filter with a Beta ratio of 1.5 to 2 has been found to be satisfactory. For some open circuit systems, and closed systems with cylinders being supplied from the same reservoir, a considerably higher filter efficiency is recommended. This applies to systems with gears or clutches using a common reservoir. For these systems, Beta ratios of 10 or 20 are typically required.

The filter capacity required depends on the amount of contaminants ingressed and retained in the filter and the desired maintenance interval. As a rough guide, a capacity in grams equal to twice the charge flow in GPM has been found to be satisfactory for our systems.

Since each system is unique, the filtration requirements for that system will be unique and must be determined by test in each case. It is essential that monitoring be the final criteria for judging the adequacy of the filtration system.

Lubrication Chart

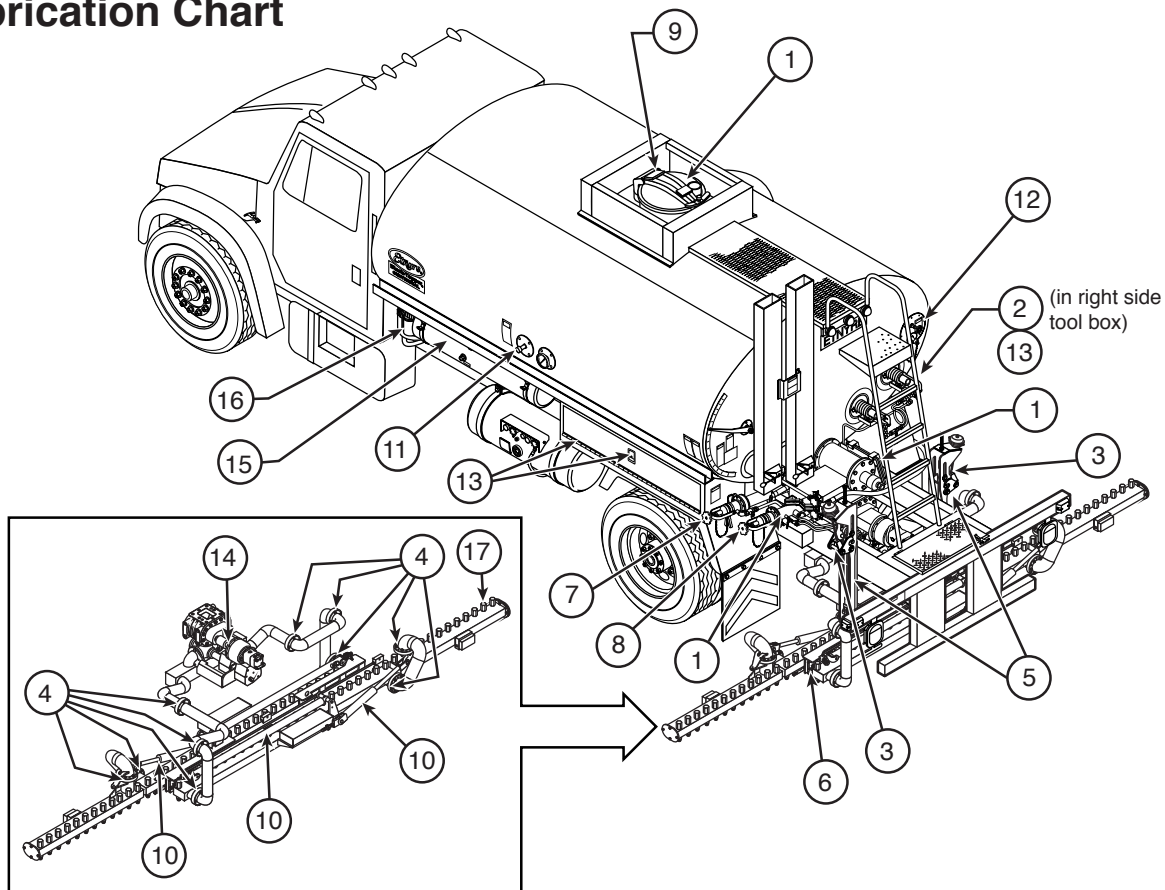

INTERVAL	POINT	IDENTIFICATION	LUBRICANT	QUANTITY
DAILY	1	Strainers (Fill Line, Manhole, Strainer Box)	Clean	—
	17	Spray Valves	HTG	Sparingly
WEEKLY	2	Air Oiler	EO	Fill
MONTHLY	3	Bar Latches	EO	Sparingly
	4	Swivels	MPG	Sparingly
	5	Bar Carry Mechanism	EO	Sparingly
	6	Bar Shoe Slide Plates	AS	Sparingly
	7	Transfer Line Cap	AS	Sparingly
	8	Load Line Cap	AS	Sparingly
	9	Manhole Lid	AS	Sparingly
	10	Exposed Hydraulic and Air Cylinder Rods	EO	Sparingly
	11	Thermometer Cap	AS	Sparingly
	12	Sample Valve Cap	AS	Sparingly
	13	Tool Box Hinge and Latch	EO	Sparingly
SERVICE	14	Pump Shaft Coupling	AS	Sparingly
	15	Hydraulic Reservoir	HTF	Fill to Top of Sight Glass
	16	Hydraulic Oil Filter	—	Replace when gauge is red

MPG: Multi Purpose Grease MIL-G-18458B-SH

AS: Anti-Seize MIL-T-5544

HTG: High Temperature Grease (450°F)

EO: (Engine Oil) 10W MIL-L-2104-F

HTF: Hydraulic Transmission Fluid - Type F

NOTE: Fill line oiler, located on outlet side of air reservoir, with light oil as needed. Also wipe cylinder rods clean and lightly oil. Drain water from air reservoir daily.

NOTE: Fill Hydraulic Tank completely for winter storage. This will prevent condensation in the reservoir. Drain down to thermometer hole prior to use.

NOTE: Grease spray valves until grease exits opposite side. Grease after cleaning spraybar with solvents or high pressure water and before and after spraying hot (+400°F) asphalt.

Etnyre Spraybar Nozzles

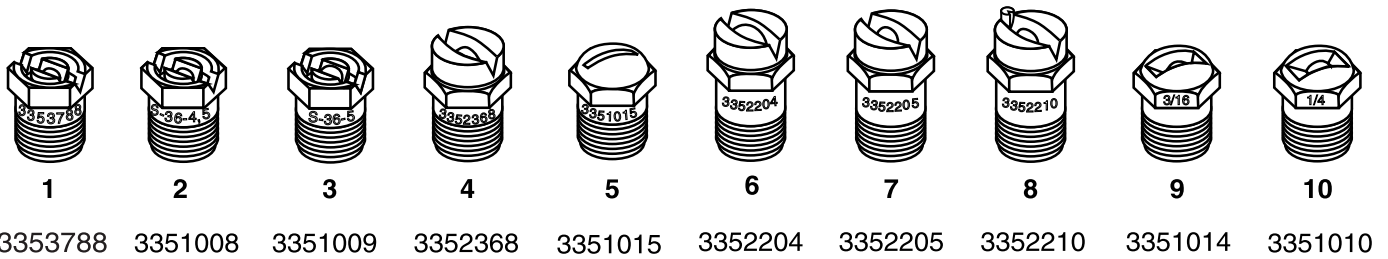

Ref.	Part No.	Description	Application Gallons Per Square Yard	Application (Metric) Liters Per Square Meter	US Flow Gallons Per Minute Per Foot
1	3353788	V Slot Tack Nozzle	.05 - .20	.23 - .91	3.0 to 4.5
2	3351008	S36-4 V Slot	.10 - .35	.45 - 1.58	4.0 to 7.5
3	3351009	S36-5 V Slot	.18 - .45	.81 - 2.04	7.0 to 10.0
4	3352368	Multi-Material V Slot	.15 - .40	.68 - 1.81	6.0 to 9.0
5	3351015	3/32" Coin Slot	.15 - .40	.68 - 1.81	6.0 to 9.0
6	3352204*	Multi-Material V Slot	.35 - .95	1.58 - 4.30	12.0 to 21.0
7	3352205*	Multi-Material V Slot	.20 - .55	.91 - 2.49	7.5 to 12.0
8	3352210	End Nozzle (3352205)	.20 - .55	.91 - 2.49	7.5 to 12.0
9	3351014	3/16" Coin Slot	.35 - .95	1.58 - 4.30	12.0 to 21.0
10	3351010	1/4" Coin Slot	.40 - 1.10	1.81 - 4.98	15.0 to 24.0

* Recommended nozzles for seal and chip with emulsified asphalts.

Serial Number Plate Location

The Serial Number Plate is a brass plate located on the left side of the vehicle toolbox. Generally, the serial number has a letter prefix followed by four numbers.

The unit serial number is also stamped on the left front tank mounting leg.

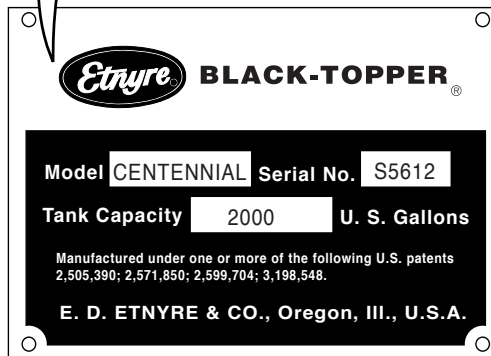
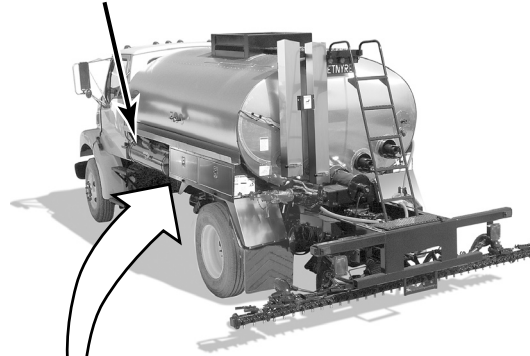

Figure 34. Serial Number Plate Location

Decimal Equivalent Chart

Fraction	Decimal
1/16	.06
1/8	.12
3/16	.19
1/4	.25
5/16	.31
3/8	.38
7/16	.44
1/2	.50

Fraction	Decimal
9/16	.56
5/8	.62
11/16	.69
3/4	.75
13/16	.81
7/8	.88
15/16	.94
1	1.00

