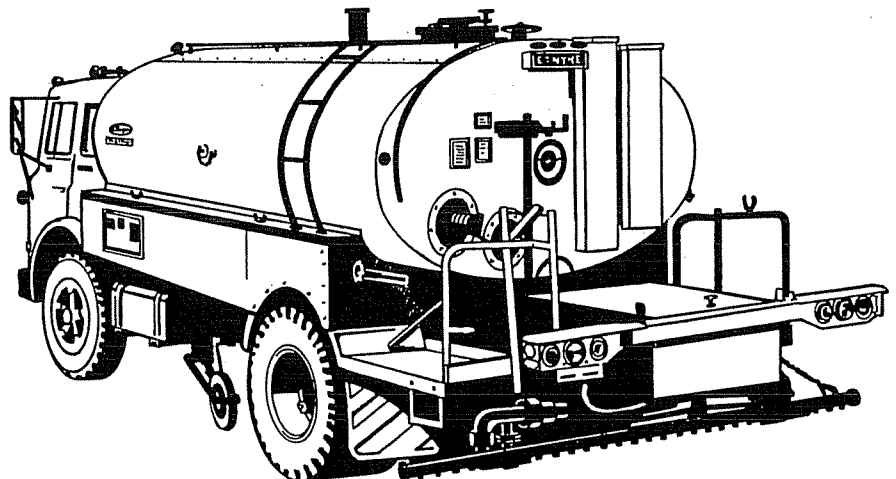
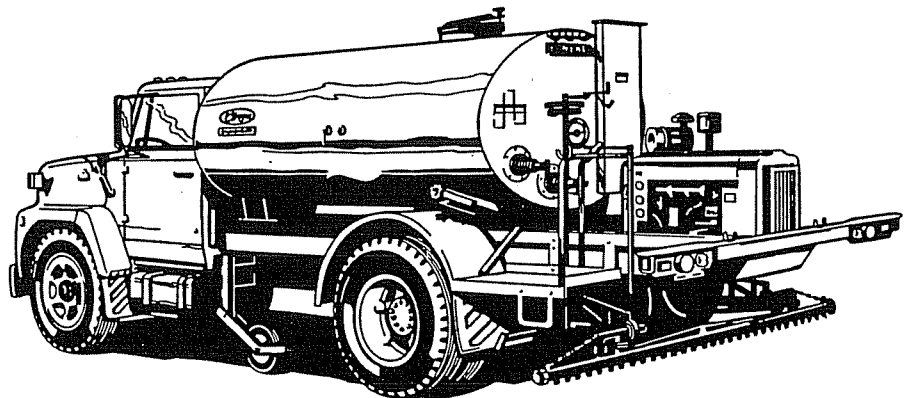




**BLACK-TOPPER®**  
**OPERATION, MAINTENANCE and**  
**SAFETY MANUAL**

**Models BT, BX and BT/SAM**



**E. D. ETNYRE & CO., Oregon, Illinois 61061**

# WARRANTY

**E. D. ETNYRE & CO.** warrants to the original Purchaser, its new product to be free from defects in material and workmanship for a period of twelve (12) months after date of delivery to original Purchaser. The obligation of the Company is limited to repairing or replacing any defective part returned to the Company and will not be responsible for consequential damages or any further loss by reason of such defect.

**THE COMPANY EXCLUDES ALL IMPLIED WARRANTIES OF MERCHANTABILITY AND FITNESS FOR A PARTICULAR PURPOSE. THERE ARE NO WARRANTIES, EXPRESS OR IMPLIED, WHICH EXTEND BEYOND THE DESCRIPTION OF THE GOODS CONTAINED IN THIS CONTRACT.**

This warranty does not obligate the Company to bear the cost of machine transportation in connection with the replacement or repair of defective parts, nor does it guarantee repair or replacement of any parts on which unauthorized repairs or alterations have been made or for components not manufactured by the Company except to the extent of the warranty given by the original Manufacturer.

This warranty does not apply to:

- (1) Normal start-up services, normal maintenance services or adjustments usually performed by the selling dealer, factory service representative or customer personnel.
- (2) Any product manufactured by E. D. Etnyre & Co. purchased for or subjected to rental use.
- (3) Any product or part thereof which shows improper operation, improper maintenance, abuse, neglect, damage or modification after shipment from factory.
- (4) Any product or part thereof damaged or lost in shipment. Inspection for damage should be made before acceptance or signing any delivery documents releasing responsibility of the delivery carrier.

This warranty and foregoing obligations are in lieu of all other obligations and liabilities including negligence and all warranties of merchantability or otherwise, express or implied in fact or by law.



# TABLE OF CONTENTS

<b>GENERAL SAFETY INSTRUCTIONS</b> .....	1
<b>INTRODUCTION</b> .....	3
REPORTING SAFETY DEFECTS .....	3
<b>COMPONENT LOCATION AND IDENTIFICATION</b> .....	4
<b>PREPARING FOR OPERATION</b> .....	10
INSPECTION .....	10
Engine Driven Units .....	10
Hydrostatic Models .....	10
<b>HYDROSTATIC DRIVE INITIAL START-UP</b> .....	10
Introduction .....	10
Start-up Instructions .....	11
<b>ESTABLISHING FLOW RATE/GROUND SPEED RATIO</b> .....	12
Introduction .....	12
Using the Etnyre Computator .....	12
Establishing Flow Rate/Ground Speed Ratio .....	13
To Spray .....	13
<b>RECORDING SETTINGS WITH HYDROSTATIC DRIVE</b> .....	13
<b>EQUIPMENT PREPARATION</b> .....	14
Draining Circulating System and Spray Bar .....	14
Draining Discharge Header .....	14
Cleaning Discharge Strainer .....	14
<b>TESTING</b> .....	14
Engine Driven Units .....	14
Hydrostatic Units .....	15
<b>START-UP OF HIGH PRESSURE FUEL OIL BURNERS</b> .....	15
Electrode Assembly Adjustments .....	15
Burner Air Band Settings .....	16
Adjust Hydraulic System Relief Valve Setting .....	16
Set Burner Blower Wheel Speeds .....	16
Check Ignition Transformer Spark .....	17
Fire Burners .....	17
<b>CALIBRATING DISTRIBUTOR</b> .....	17
<b>SPRAY BAR VALVE ADJUSTMENT</b> .....	18
"FC" Bar .....	18
"TUC" Bar .....	18
<b>FILLING INSTRUCTIONS</b> .....	20
<b>FILLING DISTRIBUTOR THROUGH FILL LINE</b> .....	20
Connections and Preliminary Checks .....	20
Preheating .....	21
Engaging Pump .....	21
Pumping .....	22
<b>FILLING DISTRIBUTOR THROUGH MANHOLE</b> .....	22
<b>HEATING BITUMEN IN DISTRIBUTOR</b>	
<b>LIQUID PROPANE GAS (LPG) BURNERS</b> .....	24
<b>LPG SUPPLY TANK REQUIREMENTS</b> .....	25
<b>MANUAL CONTROL BURNERS</b> .....	25
Burner Control Valves .....	25
Burner Operation .....	25

# TABLE OF CONTENTS

BURNERS WITH OUTFIRE CONTROL .....	26
Equipment Description .....	26
Operation .....	27
BURNERS WITH AUTOMATIC IGNITION AND TEMPERATURE LIMITING CONTROL .....	27
Equipment Description .....	27
Burner Operation .....	28
Calibrating the Thermostat .....	28
<b>HEATING BITUMEN IN DISTRIBUTOR</b>	
<b>LOW PRESSURE ATOMIZING BURNERS .....</b>	<b>29</b>
General Information .....	29
Blower Drives .....	29
PTO Drive Line Units .....	29
Hydraulic Motor Driven Units .....	30
Burner Operation on Engine Driven Units .....	30
Burner Operation on Hydrostatic Units .....	31
Units With PTO Blower Drive .....	31
Hydraulic Motor Driven Units .....	31
<b>HEATING BITUMEN IN DISTRIBUTOR</b>	
<b>HIGH PRESSURE FUEL OIL BURNERS .....</b>	<b>32</b>
<b>HEATING BITUMEN IN DISTRIBUTOR</b>	
<b>HIGH PRESSURE (KEROSENE) GENERATING BURNERS .....</b>	<b>34</b>
<b>CIRCULATING PRODUCT IN TANK .....</b>	<b>36</b>
SET-UP .....	36
Engine drive units .....	36
Hydrostatic drive units .....	37
<b>CIRCULATING PRODUCT IN BAR .....</b>	<b>38</b>
SET-UP .....	38
CIRCULATING PRODUCT IN BAR .....	38
<b>SPRAYING OPERATIONS .....</b>	<b>39</b>
GENERAL .....	39
Adjusting Spray Bar Nozzle Angle .....	39
Adjusting Spray Bar Height .....	39
Valve Settings .....	39
SPRAYING WITH ENGINE DRIVE MODELS .....	41
SPRAYING WITH HYDROSTATIC MODELS .....	41
CIRCULATING PRODUCT FOR SPRAYING OPERATIONS .....	41
SHOULDER SPRAYING .....	42
"TUC" Spray Bar .....	42
"FC" Spray Bar .....	42
DRAWING MATERIAL IN BAR BACK INTO TANK .....	43
HAND SPRAYING .....	44
PUMP OFF .....	45
AFTER SPRAYING .....	45
TRANSFERRING MATERIAL FROM SUPPLY SOURCE TO STORAGE .....	45
DRAINING CIRCULATING SYSTEM AND SPRAY BAR .....	46
FLUSHING BAR, CIRCULATING SYSTEM AND TANK .....	47
WASHOUT TO PREVENT CONTAMINATION OF THE BINDER MATERIAL .....	47
<b>TROUBLESHOOTING .....</b>	<b>48</b>

# TABLE OF CONTENTS

<b>SERVICING THE ETNYRE P-15 PUMP</b> .....	<b>50</b>
VACUUM CHECK .....	50
PUMP DISASSEMBLY AND INSPECTION .....	50
IMPELLER INSTALLATION AND PUMP ASSEMBLY .....	50
<b>HYDROSTATIC PUMPS AND MOTORS</b>	
<b>DYNAPOWER</b> .....	<b>51</b>
HYDROSTATIC MOTOR PRESSURE CHECK AND ADJUSTMENT .....	51
Equipment Required .....	51
Initial Pressure Check .....	51
Pressure Evaluation .....	51
Hydraulic Pump Case Drain Flow Rate Check .....	52
Hydraulic Motor Case Drain Flow Rate Check .....	52
Hydraulic Motor Relief Valve Adjustment .....	52
Type I Hydraulic Motor .....	53
Type II Hydraulic Motor .....	53
Type III Hydraulic Motor .....	54
DYNAPOWER GENERATION II UNITS .....	54
Case Leakage .....	54
Adjustments .....	55
<b>HYDROSTATIC PUMPS AND MOTORS</b>	
<b>SUNDSTRAND</b> .....	<b>57</b>
START-UP AND MAINTENANCE .....	57
Fluids .....	57
Start-Up Procedure .....	57
Maintenance .....	57
TROUBLESHOOTING .....	58
Gauge Installation .....	58
INSPECTIONS AND ADJUSTMENTS .....	59
Manual Displacement Control (MDC) .....	59
Hydraulic Displacement Control (HDC) Neutral Adjustment .....	59
Electric Displacement Control (EDC) Neutral Adjustment .....	59
<b>GENERAL FUEL DATA AND HEATING TERMINOLOGY</b> .....	<b>60</b>
FUEL DATA .....	60
APPROXIMATE BURNER FUEL CONSUMPTION .....	60
Propane .....	60
Low Pressure Fuel Oil .....	60
Kerosene Generating .....	60
HEATING TERMINOLOGY .....	60
Flash Point (Open Cup) .....	60
Closed Flash Point .....	60
Fire Point .....	60
Ignition Temperature (Kindling Temperature) .....	60
Convection .....	60
Conduction .....	60
<b>ACCEPTABLE HYDRAULIC FLUIDS</b> .....	<b>61</b>
<b>LUBRICATION CHART</b> .....	<b>62</b>

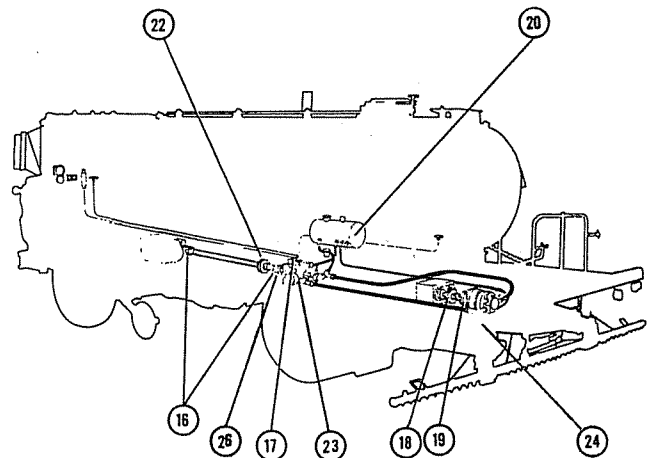
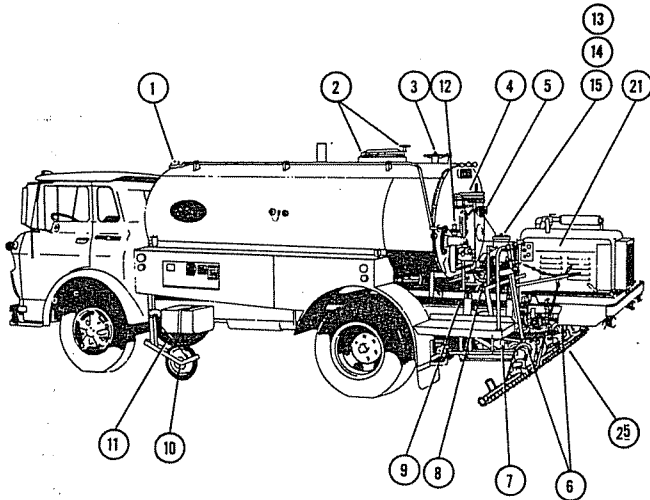
**ETNYRE BITUMINOUS DISTRIBUTOR  
ENGINE UNIT – HYDROSTATIC UNIT**

INTERVAL	POINT	IDENTIFICATION	LUBRICANT	QUANTITY
30 DAYS	1	Bell Mechanism	EO*	Sparingly
	2	Manhole Cover	EO*	Sparingly
	3	Inside Valve Handwheel	EO*	Sparingly
	4	Spray Bar Controls	EO*	Sparingly
	5	Tachometer Cable	GO	Fill
	6	Bar Turn Up Bearings	MPG	Sparingly
	7	Bar Carrying Mechanism	EO* & MPG	Sparingly
	8	Transmission	#90M-ATG	1- $\frac{1}{2}$ Qts.
	9	Pump Coupling	#2M-AG	Sparingly
	10	Bitumeter Wheel	EO*	Sparingly
	11	Bitumeter Cable	GO	Fill
	12	Air Relief Valve	EO*	Sparingly
	25	Flip Valve Lever	MPG	Sparingly
DAILY	13	Oil Bath Air Cleaner Engine & Blower	EO	Fill to Line
	14	Blower Gear Case	EO	7 Oz.
	15	Blower Clutch Drive	MPG	Sparingly
	16	Drive Universals	#2M-AG	Sparingly
	17	Control Linkage	EO*	Sparingly
	18	Pump Universal	#2M-AG	Sparingly
	19	Tachometer Drive Chain	EO*	Sparingly
	20	Hydraulic Reservoir	HTF	$\frac{1}{2}$ Full**
	21	Gasoline Engine		See Eng. Manual
	22	V-Belt Sheave Idler Brg.	KER	Wash Twice Yearly
	23	Hydraulic Oil Filter		Replace if vacuum gauge shows in red area.
	24	Pump Discharge Strainer		Clean Weekly
ANNUALLY	26	Pump Spline Fitting Yoke	#67-71	Sparingly

#67-71: Anti-seize Compound  
 #2M-AG: #2 Molub Alloy Grease  
 #90M-ATG: #90 Molub Alloy Transmission Grease  
 MPG: Multipurpose Type Grease  
 HTF: Hydraulic Transmission Fluid - Type A  
 GO: Graphite Oil  
 EO: Engine Crankcase Oil  
 EO\*: Engine Crankcase Oil/Applied W/Oil Can  
 KER:Kerosine

NOTE: On units with one man air controls - fill line oiler, located on outlet side of air reservoir, with light oil as needed. Also wipe cylinder rods clean and lightly oil. Drain water from air reservoir daily.

\*\*Fill completely for winter storage. This will prevent condensation in reservoir. Drain down to thermometer hole prior to use.



# GENERAL SAFETY INSTRUCTIONS

The operation of a bituminous distributor normally requires the handling of liquid products at elevated temperatures. Additionally, these liquids may be of a volatile nature. A heating system is supplied to raise or maintain the product temperature, and these systems use highly combustible fuels. And, as with any type of construction equipment, there are certain hazards associated with improper or careless operation.

Safety warnings have been provided to call attention to any potentially hazardous situation that may cause personal injury or death to the operator or bystanders. These safety warnings are identified by the following warning symbol.



- The **DANGER** symbol alerts you to immediate hazards which **WILL** result in severe personal injury or death.
- The **WARNING** symbol alerts you to hazards which may cause severe personal injury or death.

All of these warnings are listed below, and they also appear throughout the manual.

You will also find **CAUTIONS** and **NOTES** throughout the manual.

- A **CAUTION** alerts you to procedures that may result in damage to the equipment if not followed properly.
- A **NOTE** provides general information that the operator should be aware of when performing an operation.

**DANGERS, WARNINGS** and **CAUTIONS** always precede the instructions to which they apply.

## **DANGER**

To avoid an extreme fire hazard or explosion, **NEVER** use gasoline as fuel in low pressure or generating burners.

## **WARNING**

A fully charged dry chemical type fire extinguisher must be within easy reach whenever the burners are operating or there is an open flame near the distributor. Minimum dry chemical capacity of the fire extinguisher should be 10 pounds.

To prevent an explosion or fire hazard: Eliminate sparks from engine exhausts.

To prevent an explosion or fire hazard: Position unit broadside to wind whenever possible to prevent volatile fumes from drifting toward burners.

To prevent an explosion or fire hazard: Flues must be covered by a minimum 6 inches of material (bitumen) when burners are in operation.

To prevent an explosion or fire hazard: Do not remove material from tank in any manner when burners are in operation.

## **WARNING**

To prevent an explosion or fire hazard: Do not operate burners if tank is damaged or leaking.

To prevent an explosion or fire hazard: Do not operate burners when vehicle is unattended, when vehicle is in motion, or with vehicle in a confined area.

To prevent an explosion or fire hazard: When burners go out, shut off fuel supply to both burners and allow flues to ventilate for several minutes before re-lighting burners.

To prevent an explosion or fire hazard: Do not heat material beyond the manufacturer's recommended temperature.

To prevent an explosion or fire hazard: Keep burning cigarettes or other sources of combustion away from manholes and overflow vents.

To prevent possible hand or facial burns: Always light inside burner first. Do not reach across a lit burner to light (or re-light) inside burner. Shut off outside burner before lighting inside burner.

To prevent possible burns: Always use a torch to light burners. Never attempt to light burners with a match or pocket lighter.

# GENERAL SAFETY INSTRUCTIONS

## **⚠ WARNING**

To prevent possible burns from leaking material: Be sure all pipe, cap and hose connections are secure before opening valves.

To prevent possible burns from hot asphalt spray: Do not stand, or allow anyone to stand, where accidental opening of a valve may cause contact with hot asphalt.

To prevent burns from accidental spraying: TUC bar must be OFF and remain OFF when spray bar is rotated upward.

To prevent an explosion or fire hazard: Keep area free of sparks or open flames when spraying with volatile materials.

To prevent foaming or violent eruption: Do not load tank with material temperature over 200° F if water or condensation is present in tank, or if emulsion was used in the previous load. Clean and thoroughly drain tank first. If water or emulsion may be present in spray bar or circulating system, allow a small amount of hot material to circulate in bar BEFORE filling tank. Do not heat material over 200° if moisture or emulsion is present in tank.

## **⚠ WARNING**

To prevent possible burns from hot asphalt spray when hand spraying: Hold hand spray gun in proper position and watch for other people.

To prevent burns: Always wear insulated gloves when handling spray bar sections or hoses.

To prevent severe injury from becoming entangled in machinery: Stand clear of rotating drives.

To prevent possible injury: Always open manhole cover slowly. Pressure build-up in tank may cause cover to burst open.

To prevent possible fire hazards, burns or falls: Keep unit clean for safe operation.

To prevent being struck by control lever on rear quadrant: Stand clear when ON/OFF function is being performed with air control.

To prevent possible burns from material overflow: Allow sufficient space in tank for expansion of material when heating.



# INTRODUCTION

Your Etnyre Distributor is designed to give you many years of accurate, dependable, and economic service. The following instructions will enable you to receive the maximum performance from your distributor.

The distributor controls are designed for simple operation. They require a minimum of training for proficient usage. The exclusive Etnyre circulating system is designed and built for handling all grades of bituminous materials efficiently.

This manual is provided as a tool to aid both experienced and inexperienced personnel to operate the Etnyre Black-Topper in a safe and efficient manner. As with any type of construction equipment, there are certain hazards associated with improper or careless operation. The ability to read and understand the instructions in this manual should be a required qualification to become an operator. There are also functions that require a certain amount of physical strength to accomplish. An average adult male should be capable of performing the more strenuous tasks. Women need not be excluded from operating a distributor as long as they possess the necessary strength. Persons lacking the

required strength may not only place themselves in jeopardy, but also others in the vicinity.

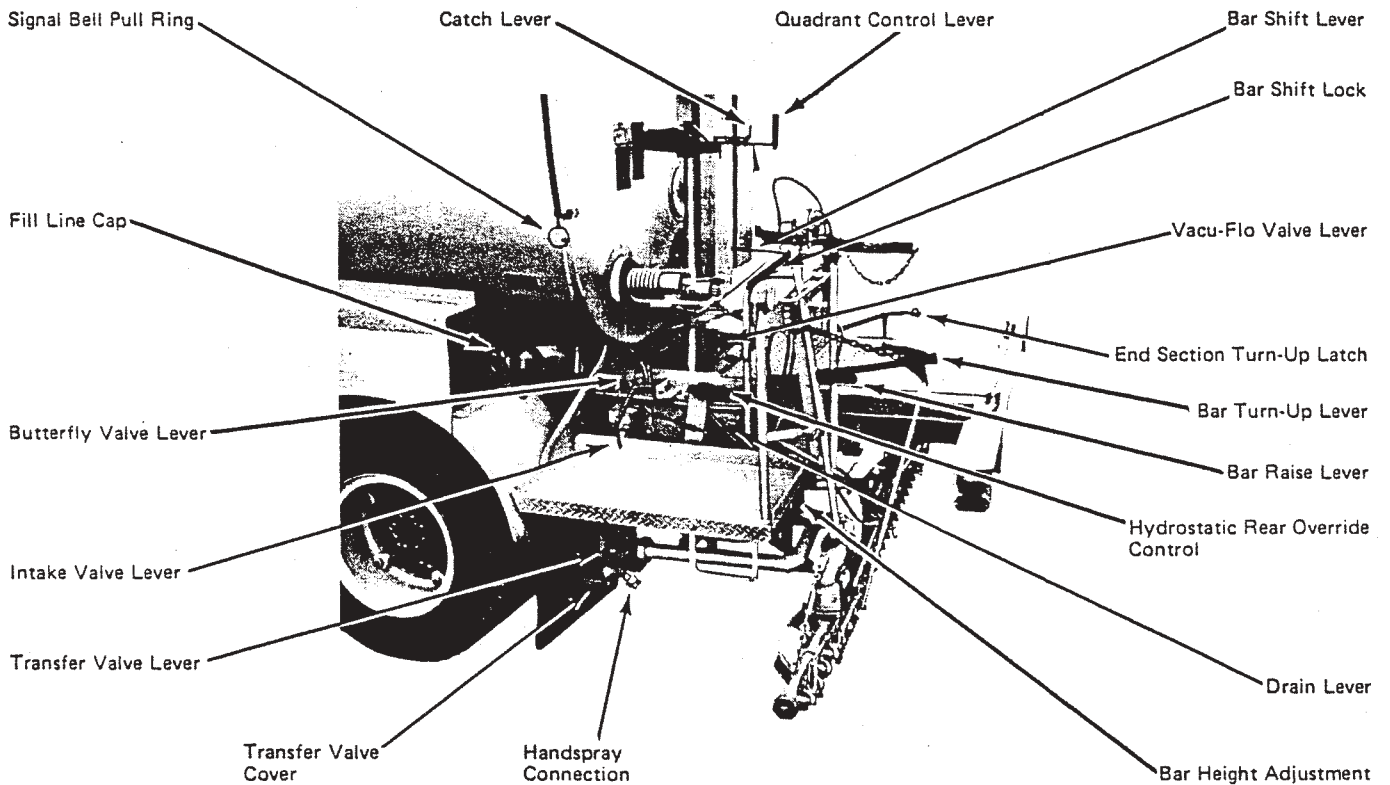
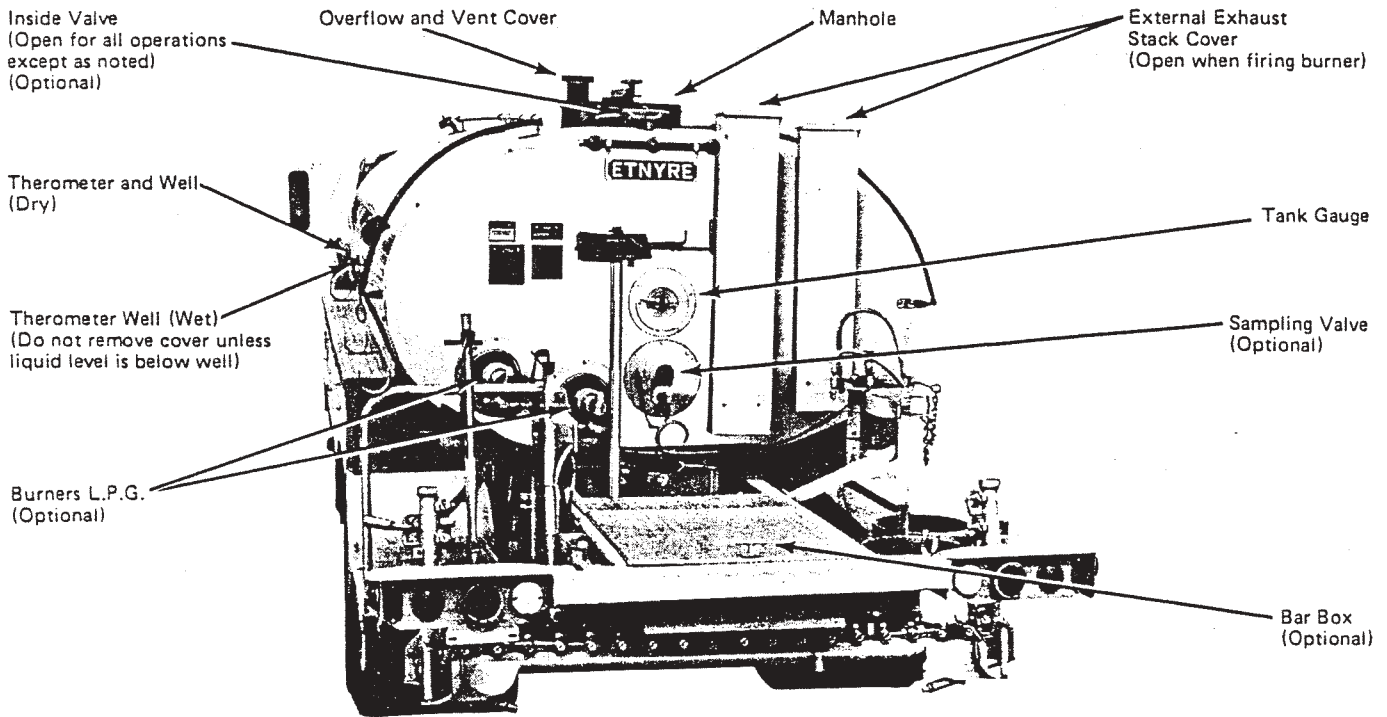
## REPORTING SAFETY DEFECTS

If you believe that your vehicle has a defect which could cause a crash, or could cause injury or death, you should immediately inform the National Highway Traffic Safety Administration (NHTSA) in addition to notifying E. D. Etnyre & Co.

If NHTSA receives similar complaints, it may open an investigation; and, if it finds that a safety defect exists in a group of vehicles, it may order a recall and remedy campaign. However, NHTSA cannot become involved in individual problems between you, your dealer, or E.D. Etnyre & Co.

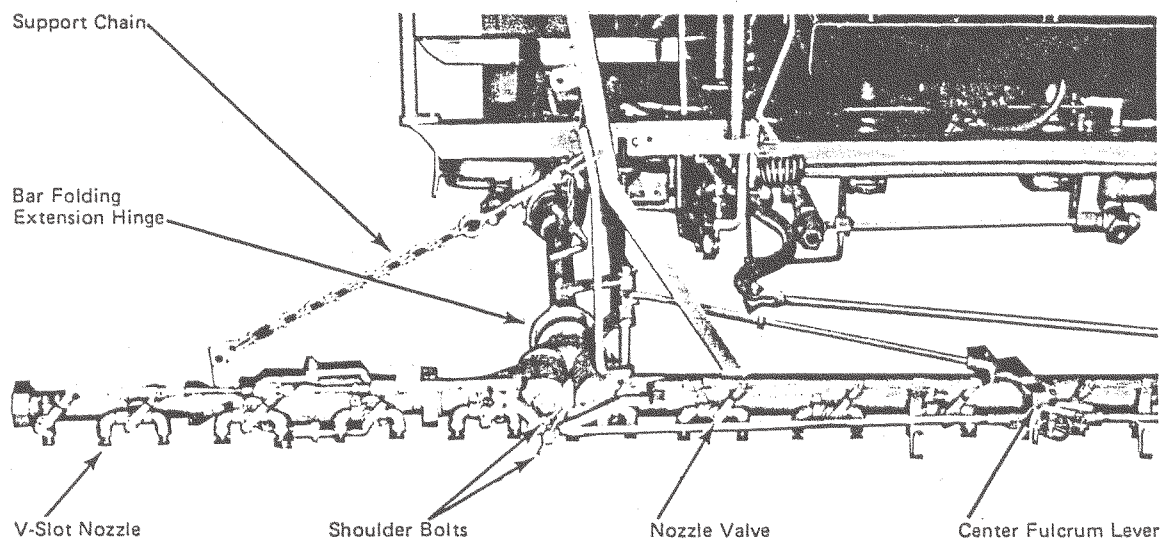
To contact NHTSA, you may either call the Auto Safety Hotline toll-free at 1-800-424-9393 (or 366-0123 in the Washington, D.C. area), or write to: NHTSA, U.S. Department of Transportation, Washington, D.C., 20696. You can also obtain other information about motor vehicle safety from the hotline.

# COMPONENT LOCATION AND IDENTIFICATION

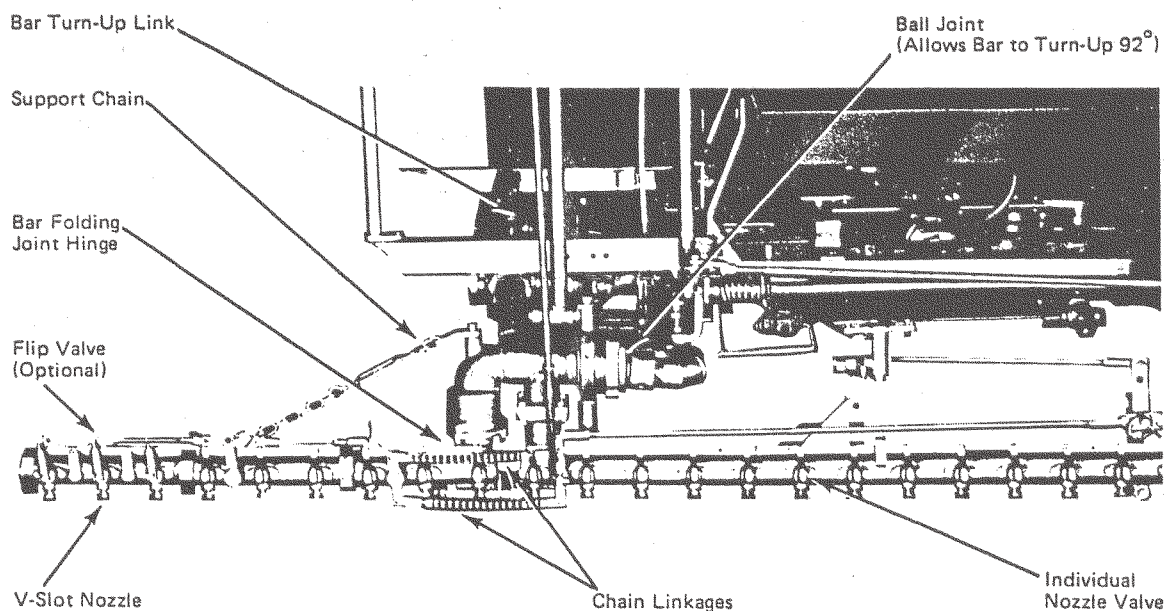


# COMPONENT LOCATION AND IDENTIFICATION

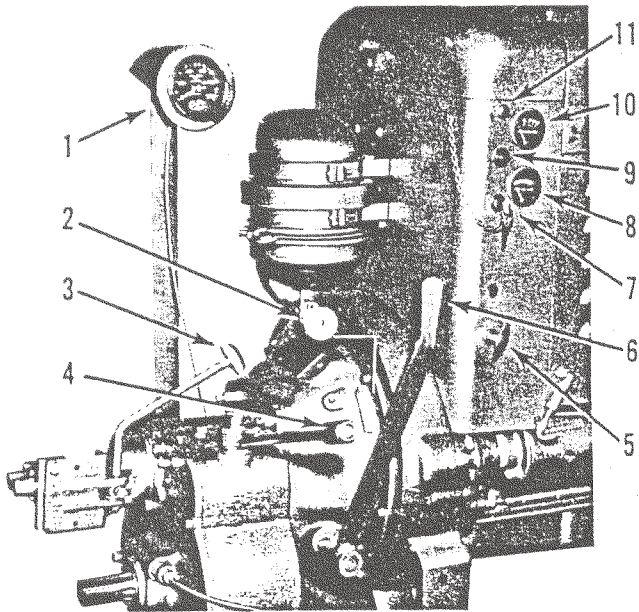
## "FC" SPRAY BAR



## "TUC" SPRAY BAR

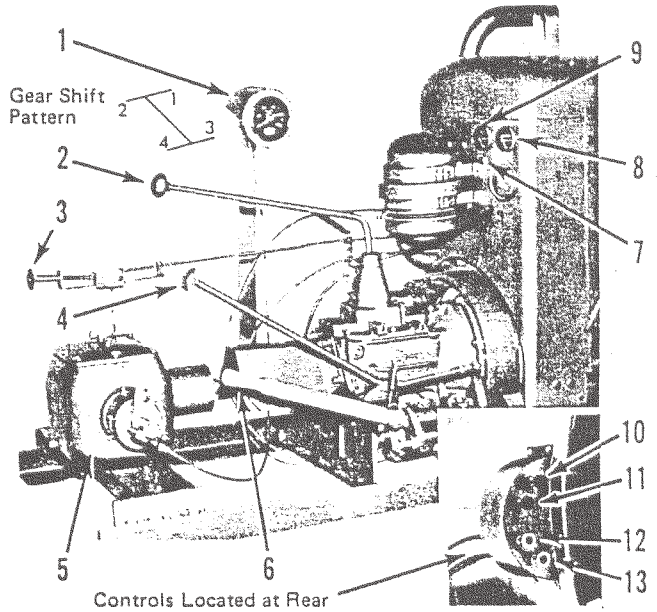


# COMPONENT LOCATION AND IDENTIFICATION



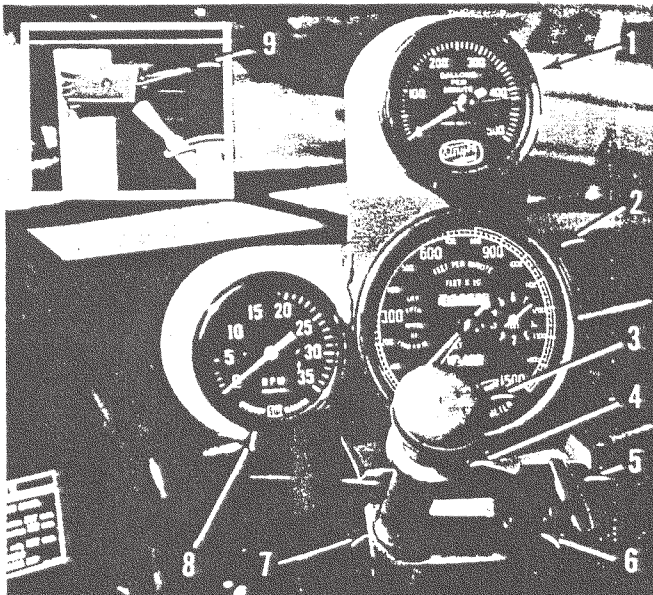
REAR ENGINE

- |  |                               |
|--|-------------------------------|
| 1. Pump Tachometer (G.P.M.)                | 6. Main Clutch Lever          |
| 2. Governor Control                        | 7. Ignition Switch            |
| 3. Fuel Pump and/or Blower<br>Clutch Lever | 8. Temperature Gauge          |
| 4. Gear Shift                              | 9. Starter Switch             |
| 5. Choke                                   | 10. Oil Pressure Gauge        |
|  | 11. Generator Indicator Light |



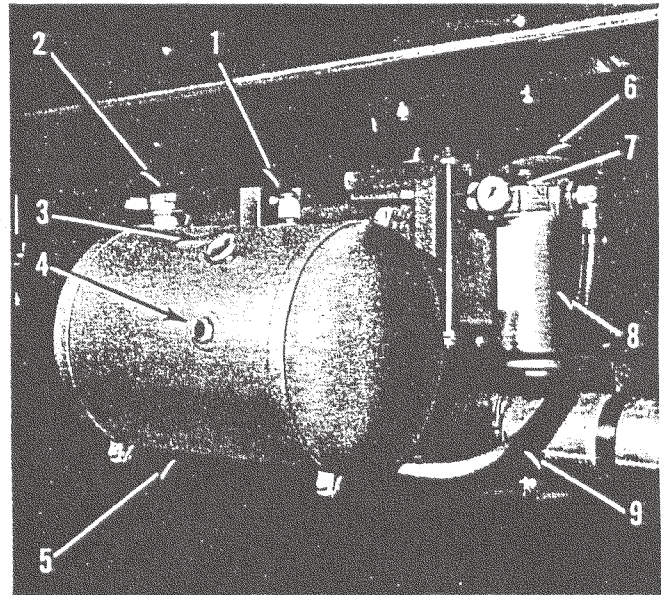
FRONT ENGINE

- |  |                              |
|--|------------------------------|
| 1. Pump Tachometer (G.P.M.)                | 7. Generator Indicator Light |
| 2. Gear Shift                              | 8. Temperature Gauge         |
| 3. Governor Control                        | 9. Oil Pressure Gauge        |
| 4. Fuel Pump and/or Blower<br>Clutch Lever | 10. Starter Switch           |
| 5. Angle Drive                             | 11. Ignition Switch          |
| 6. Main Clutch Lever                       | 12. Choke                    |
|  | 13. Throttle                 |



HYDROSTATIC CONTROLS (CAB MOUNTED)

- |                             |   |
|-----------------------------|---|
| 1. Pump Tachometer (G.P.M.) | 6. High Temperature Light                                     |
| 2. Recording Bitometer      | 7. Lock Ring  |
| 3. Main Hydraulic Control   | 8. P.T.O. Tachometer R.P.M.<br>(Automatic Transmissions Only) |
| 4. Fine Control Knob        | 9. Hydrostatic Rear Override Control                          |
| 5. Override Control         |   |

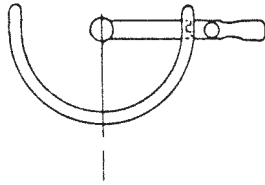


HYDROSTATIC RESERVOIR AND FILTER

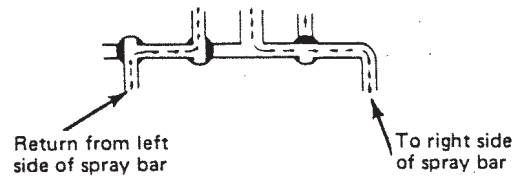
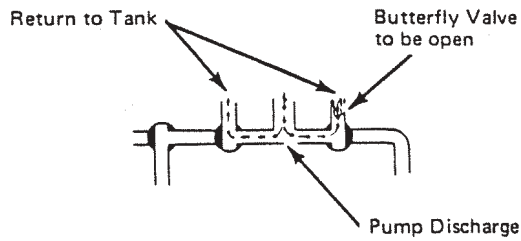
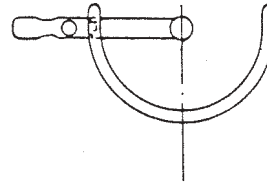
- |                                       |                                       |
|---------------------------------------|---------------------------------------|
| 1. Air Vent                           | 5. Hydraulic Reservoir                |
| 2. Fill Cap                           | 6. Hydraulic Line Filter to Pump      |
| 3. Hydraulic Oil Temperature<br>Gauge | 7. Vacuum Gauge                       |
| 4. Oil Level Sight Glass              | 8. Filter                             |
|                                       | 9. Hydraulic Line Reservoir to Filter |

# COMPONENT LOCATION AND IDENTIFICATION

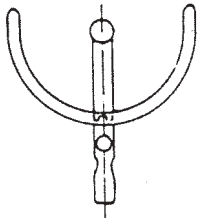
**FILLING -  
CIRCULATING IN TANK -  
CLEANING BAR WITH VACU-FLO -**  
Lever at right



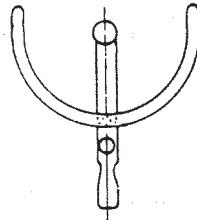
**CIRCULATING IN BAR -  
CLEANING BAR WITH AIR  
FROM INTAKE -**  
Lever to left



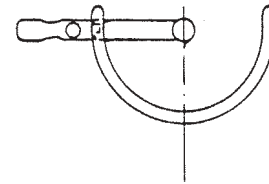
**DISTRIBUTING -**  
Press Thumb Button or Pull Catch  
Depending on Model. Lever 90°  
to center against stop.



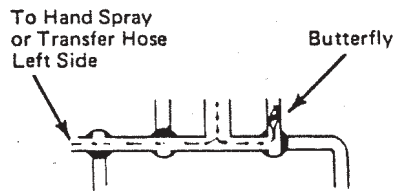
**HAND SPRAYING  
TRANSFERRING LEFT SIDE**  
Lever to center



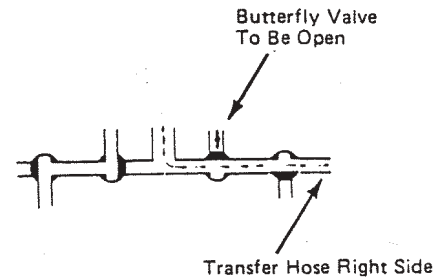
**TRANSFERRING -  
OPTIONAL RIGHT SIDE -**  
Lever to left



Both lines open to bar  
Both return lines closed



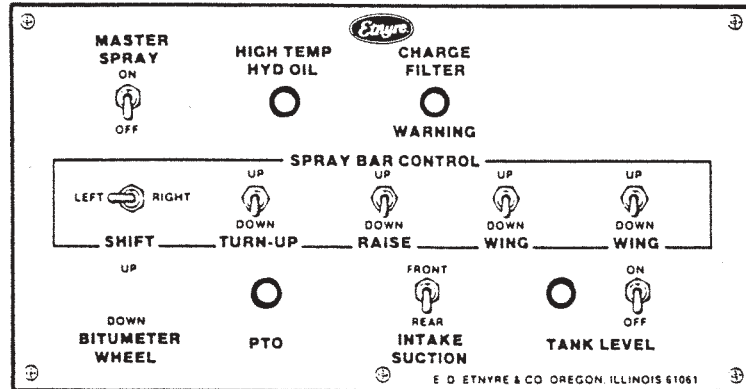
To Handspray - Turn Butterfly Valve  
till desired pressure is obtained.  
To Transfer - Close Butterfly



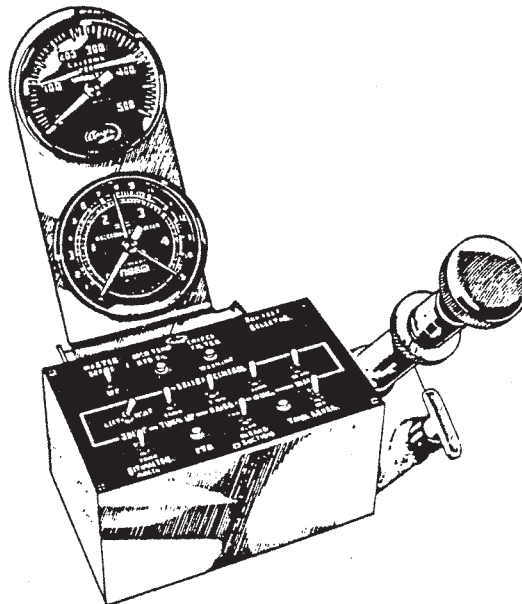
VALVE POSITIONS CORRESPOND TO LEVER POSITIONS SHOWN ABOVE

# COMPONENT LOCATION AND IDENTIFICATION

BT Control Panel

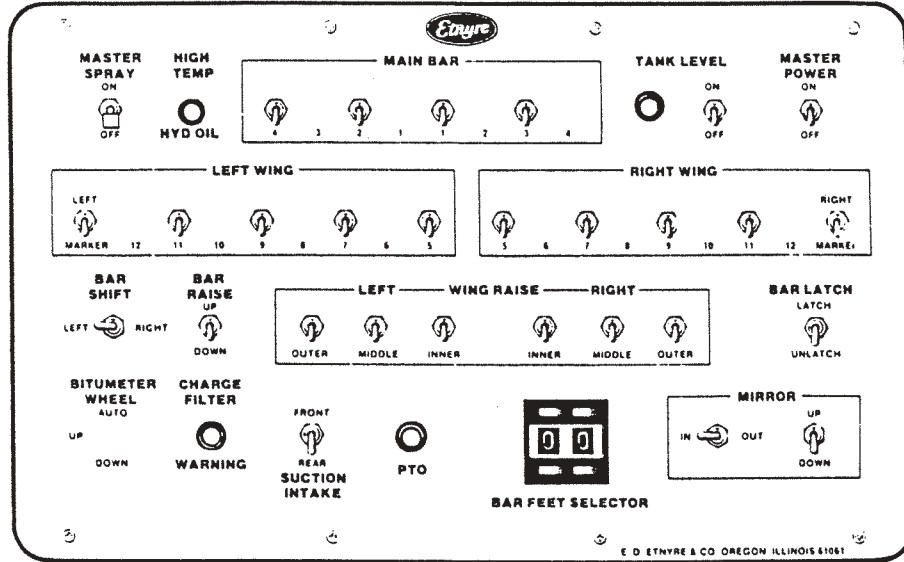


BT Cab Controls  
Used Prior To December 1990

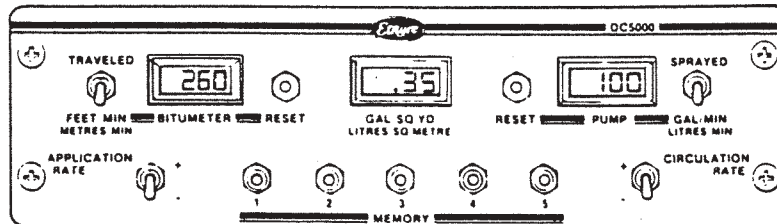


# COMPONENT LOCATION AND IDENTIFICATION

BT/SAM Control Panel



DC5000 Unit



# PREPARING FOR OPERATION

## INSPECTION

The following procedures apply to new or rebuilt units.

**NOTE:** Refer to the chassis owner's manual for chassis and engine maintenance information.

1. Inspect unit for damage that may have occurred during transport.
2. Check and tighten all fasteners, body tie-down bolts, pipe and circulating line connections, etc., that may have loosened in transit.

## Engine Driven Units

1. Refer to engine owner's manual for detailed engine maintenance and operating instructions. Be sure engine oil and radiator coolant are proper grade for operating conditions.

**NOTE:** Export units are processed to prevent corrosion during shipment. Crank engine several times and then drain and replenish engine crankcase oil with oil of proper viscosity for operating conditions.

2. Check oil level in air cleaners.
3. Lubricate vehicle per Lubrication Chart on Page 62.
4. On front engine models with double universal joint, lubricate universal joints with No. 2M-AG grease.
5. On rear engine models with collapsible square couplings, apply a few drops of cylinder oil to couplings.

## Hydrostatic Models

Check the fluid level in the hydraulic reservoir. The fluid must always be visible in the sight glass, and preferably within 3-4 inches of the top of the reservoir.

## HYDROSTATIC DRIVE INITIAL START-UP

### Introduction

The following procedures will help avoid cavitating the pump and causing possible damage to the pump components at initial start-up.

**NOTE:** These procedures are for use at initial start-up of a new machine; after replacement of the hydraulic pump; or after any hydraulic repairs during which the hydraulic system has been opened or drained.

### CAUTION

To avoid possible damage to the hydraulic pump, the hydraulic pump should NEVER be run, even for a short period, without being sure that there is hydraulic oil in the hydraulic pump case and in the charge pump.

1. Ensure that the plumbing connections match the direction of pump rotation as follows:

### WARNING

To prevent becoming entangled in machinery, use extreme caution around rotating drives. Wear close fitting clothing and appropriate safety equipment.

- a. On units with PTO drives, jog the pump drive shaft by bumping the clutch. On units with crankshaft drive, "bump" the engine starter. Check the direction of PTO rotation.
  - b. On units with automatic transmissions and PTO drives, start the engine with the transmission in neutral. Set the brakes. Shift the transmission into forward gear and engage the PTO. Shift the transmission into and out of neutral quickly while someone checks the direction of PTO rotation.
2. Check to see that the hydrostatic plumbing matches the direction of rotation of the hydraulic pump shaft (see Figure 1.).



# PREPARING FOR OPERATION

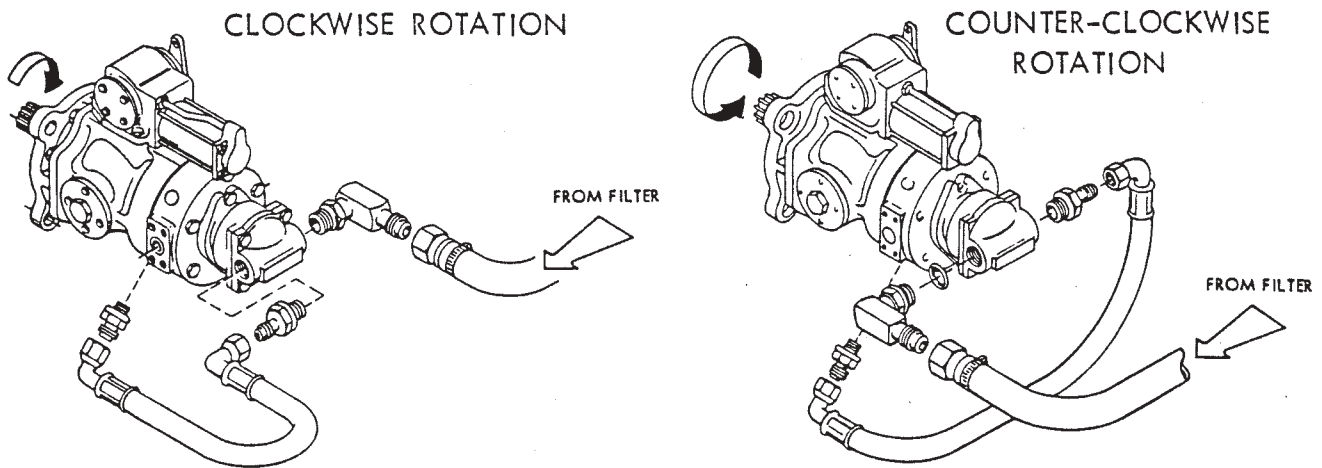


Figure 1. Hydrostatic Pump Rotation and Plumbing Connections

## Start-Up Instructions

1. Place a large pan or container beneath the hydraulic pump.
2. Remove the plug on one pump trunnion (see Figure 1.).
3. Loosen the fitting on the charge pump outlet (see Figure 1.).

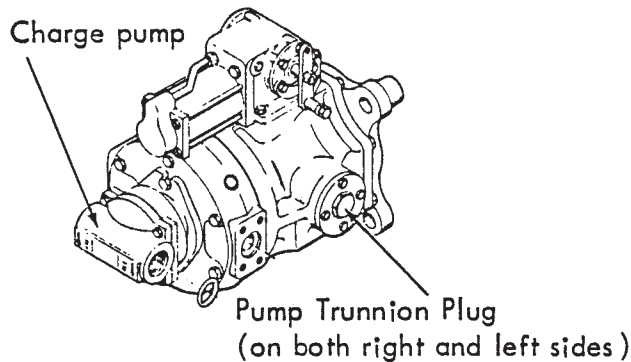


Figure 2. Pump Trunnion Plug and Charge Pump Outlet Locations

4. Fill the hydraulic tank with hydraulic oil of the correct grade and viscosity. See Page 61 for acceptable hydraulic fluids.
5. Check to see that hydraulic oil comes out of both the pump trunnion hole and the charge pump outlet. If oil does not come out of both the pump trunnion hole and the charge pump outlet, it will be necessary to pressurize the hydraulic tank to force hydraulic fluid into the pump case and the charge pump as follows:

- a. Install the necessary fittings and an air pressure regulator on the threaded fill neck of the hydraulic tank.
  - b. Apply air pressure at 10 PSI to the hydraulic tank. This will force hydraulic fluid into the pump case and the charge pump.
  - c. When oil appears at both the pump trunnion hole and the charge pump outlet, replace the fittings and tighten securely.
  - d. Release the air pressure on the hydraulic tank and remove the fittings and regulator. Replace the fill cap on the hydraulic tank.
6. Ensure that the hydraulic pump is in neutral (hydraulic control knob all the way up).
  7. Engage the PTO and start the engine at idle.

## **CAUTION**

*To avoid possible damage to the hydraulic pump, the hydraulic pump should NEVER be run, even for a short period, without being sure that there is hydraulic oil in the hydraulic pump case and in the charge pump.*

**NOTE:** Cold hydraulic oil may cause a higher than normal vacuum reading. The vacuum reading should return to the normal range when the oil has warmed.

8. Check the vacuum gauge on the hydraulic filter. The gauge should read approximately 2–10 Hg. If not, shut off engine immediately! Determine cause of high or low vacuum and correct before proceeding.

# PREPARING FOR OPERATION

- Run the hydraulic pump in neutral for 2-3 minutes with the engine at 1000-1200 RPM. This will allow time for the charge pump to fill the system with oil.

## CAUTION

To avoid possible damage to the asphalt pump, ensure that there is oil in the asphalt pump before turning the hydraulic motor.

- Slowly move the hydraulic pump out of neutral by pushing down slightly on the hydraulic control knob.
- Check to see that the hydraulic motor is turning. If not, shut off system and determine cause before proceeding.
- When motor is turning, run system at low speed for 5-10 minutes to allow air bubbles to work out of hydraulic oil. Check entire hydraulic system for leaks while system is running.
- Shut system down and fill hydraulic tank to proper level.
- The system is now ready for testing at higher speeds and pressures.

## ESTABLISHING FLOW RATE/GROUND SPEED RATIO

### Introduction

The hydrostatic drive consists of a variable output pump driven by the truck PTO, which in turn drives the distributor asphalt pump via a hydrostatic motor. Once the correct ratio between ground speed and pump flow rate is established for a given transmission setting, the truck speed may be varied without affecting the application rate.

### Using the Etnyre Computator

- To determine the proper speed and pump discharge use the Etnyre computator. On the top scale find the spray bar length to be used.
- At the end of the computator, grasp the black portion and move the center slide until the desired application rate is directly below the spray bar length (i. e., 12 feet over .30).
- In a straight line below the application rate you will find the distributor speed (in feet per minute), and directly below the feet per minute the pump discharge (in gallons per minute).

Example: Width of Spray	12 feet
Application Rate	.30
Distributor Speed	300 FPM
Pump Discharge	120 GPM

- Select a transmission gear that will provide 300 FPM at 1200 - 1600 RPM on the truck engine.

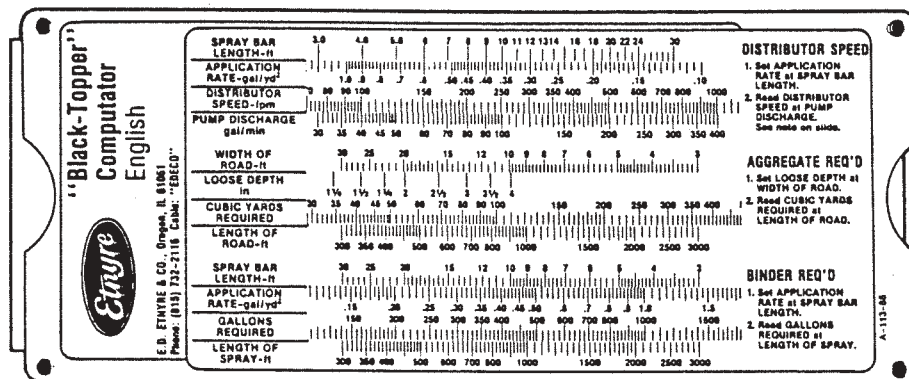


Figure 3. Etnyre Computator

# PREPARING FOR OPERATION

## Establishing Flow Rate/Ground Speed Ratio

1. Use the Etnyre Computator to determine the following:
  - a. Correct ground speed in feet per minute (FPM).
  - b. Pump flow rate in gallons per minute (GPM) for the desired spray bar length in feet (FT).
  - c. Application rate in gallons per square yard (GAL/SQ YD).
2. Place Quadrant Control Lever in "Circulate in Tank" position.
3. Pull hydraulic control knob to uppermost position.
4. Lower ground speed tachometer drive wheel to ground.
5. Engage truck PTO.
6. Select truck transmission setting and, if necessary, auxiliary and rear axle setting, to give adequate ground speed and power for the desired application rate.

**NOTE:** *More than one attempt may be necessary before the proper gear setting is determined that will prevent jerky forward motion and still provide adequate power and speed for the terrain.*

7. Now, while driving the distributor forward at the speed (FPM) previously determined from the computator, push the hydraulic control knob down until the asphalt pump flow rate is equal to the GPM determined from the computator.
8. The hydraulic control knob should be held in this position by turning the fine control tube up until it is against the bottom of the hydraulic control knob. Lock the tube in place with the brass lock ring.

Now that a dry run has been completed, record the truck gear setting, spray bar length, application rate and engine tachometer RPM so the application rate can be duplicated in the future by merely using the truck engine tachometer to establish the proper pump flow rate. An ETNYRE SHOT GUIDE has been provided for this purpose (see Figure 4.). Also refer to next section "Recording Settings With Hydrostatic Drive," for additional Shot Guide instructions.

## To Spray

1. Lower spray bar to spraying position.
2. Adjust spray bar length to predetermined length.
3. Engage truck PTO.

**NOTE:** *Prior to placing quadrant control lever in "Circulate in Bar" position, decrease pump flow rate to a maximum of 160 GPM by raising hydraulic control knob. This is done to prevent excessive pressure in the spray bar when not spraying.*

4. Place Quadrant Control Lever in "Circulate in Bar" position.
5. Engage truck transmission in gears previously determined for proper application speed.
6. Increase truck speed until pump flow rate is approximately 75% of the original determined flow rate. Upon reaching starting point, push hydraulic control knob down against stop and turn on spray bar.

**NOTE:** *Once started, the operator may drive up to a speed at which the pump flow rate (GPM) is 1-1/2 times greater or down to a speed at which the flow rate is 3/4 of the original determined flow rate. At speeds higher than recommended, fogging starts to occur. At speeds less than recommended, insufficient flow results in a fan which is less than full width.*

7. Upon completion of the shot, turn off the spray bar and, if necessary, decrease the flow rate to a maximum of 160 GPM.

## RECORDING SETTINGS WITH HYDROSTATIC DRIVE

1. Refer to Figure 4. below. Enter distribution rate in space at lower left of chart.
2. Enter corresponding distributor speed in space at lower center of chart.
3. Enter bar length in left column of chart.
4. Enter pump flow rate in second column of chart.
5. Make a dry run at indicated distributor speed. Make note of the truck RPM, transmission gear and rear axle setting that provides the best operation at the required speed.

**NOTE:** *Space is also provided for units with two-speed PTO or auxiliary transmissions.*

# PREPARING FOR OPERATION

6. Maintain distributor speed and set hydraulic control in accordance with instructions. Enter data in the appropriate column of chart.
7. Whenever a repeat of the distribution rate is called for with a previously recorded bar length reset the pump flow rate to the corresponding engine RPM with unit stationary. All other settings must also correspond.

Bar Length	Pump Discharge	Truck Eng. RPM	Tran. Gear	P.T.O. Gear	Rear Axle Gear	Aux. Tran. Gear
16 FT	160 GPM	1310	1	—	HIGH	—
24 FT	240 GPM	1310	1	—	HIGH	—
SAMPLE						

Dist. Rate 0.3 GAL/yd<sup>2</sup> Dist. Sp. 300 FPM

Bar Length	Pump Discharge	Truck Eng. RPM	Tran. Gear	P.T.O. Gear	Rear Axle Gear	Aux. Tran. Gear

Dist. Rate \_\_\_\_\_ Dist. Sp. \_\_\_\_\_

**Figure 4. Etnyre Shot Guide**

8. Use a different chart for each distribution rate. In time all necessary settings will be recorded. Additional charts are available in the "Etnyre Shot Guide." Copies may be obtained from E.D. Etnyre & Co.

## EQUIPMENT PREPARATION

### Draining Circulating System and Spray Bar

1. Turn control levers to drain position to drain any testing oil or condensation from circulating system.
2. Turn all control levers to the closed position.

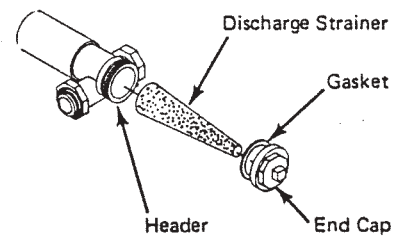
### Draining Discharge Header

Place a suitable container under the discharge header cap and remove the cap. Allow any oil or condensation to drain.

### Cleaning Discharge Strainer

1. Place a suitable container under the discharge header cap and remove the cap.
2. Remove discharge strainer and clean with diesel fuel.
3. Install strainer in discharge header as shown in Figure 5. and install header cap.

**NOTE:** Projection on header cap should be inserted into opening in end of strainer cone to keep strainer centered in discharge pipe.



**Figure 5. Installing Discharge Strainer**

## TESTING

### ⚠ WARNING

To prevent possible foaming or violent eruption, never use water to test the distributor.

### Engine Driven Units

1. Start engine and set at fast speed.
2. Shift transmission to either high or low gear.

### ⚠ CAUTION

To prevent damage to the asphalt pump, do not run pump for more than 10 minutes without bitumen to supply lubrication.

3. Engage clutch.
4. Check that asphalt pump is turning and that pump tachometer is registering pump output speed.

# PREPARING FOR OPERATION

## Hydrostatic Units

1. Push in override control located at rear platform.
2. Pull up on cab hydraulic control knob.
3. Start truck engine in with transmission in neutral and engage PTO.

## Trucks With Manual Transmission

Depress the clutch and pull outward or upward on the PTO control knob. If the PTO fails to engage, gently allow the clutch pedal upward until engagement occurs.

Ensure that truck parking brake is engaged before exiting cab.

## Trucks with Automatic Transmission

Push down on the foot brake pedal, move the gear selector to any forward gear, and pull upward or outward on the PTO control knob. When PTO engages move gear selector to neutral.

**NOTE:** *If the PTO fails to engage, continue pulling on the knob while releasing the brake pedal sufficiently to allow the truck to inch forward until the PTO engages, then move the gear selector back to neutral.*

Ensure that truck parking brake is engaged before exiting cab.

## **CAUTION**

*To prevent damage to the asphalt pump, do not run pump for more than 10 minutes without bitumen to supply lubrication.*

At the rear platform, carefully pull out the rear override control to determine if the asphalt pump drive is turning freely. Push the rear override control inward and return to the truck cab.

Push down the hydraulic control knob and watch the pump tachometer to make certain the pump output increases as the knob is depressed and returns to zero output when the knob is fully retracted.

## START-UP OF HIGH PRESSURE FUEL OIL BURNERS

**NOTE:** *These instructions are for initial start-up of new or rebuilt burners only.*

## Electrode Assembly Adjustments

1. Adjust electrode assembly per Figure 6.

**NOTE:** *Before installing electrode assembly, check that blower wheel turns freely and that all setscrews are tightened securely.*

2. Install electrode assembly into air tube unit. Use escutcheon plate for mounting (see Figure 7.).

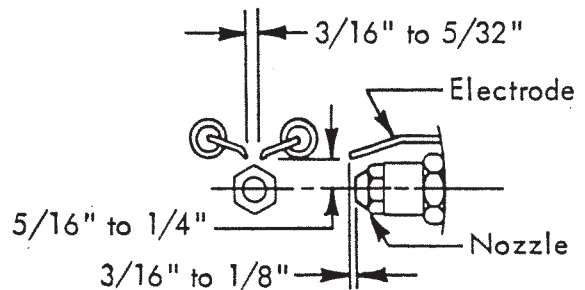
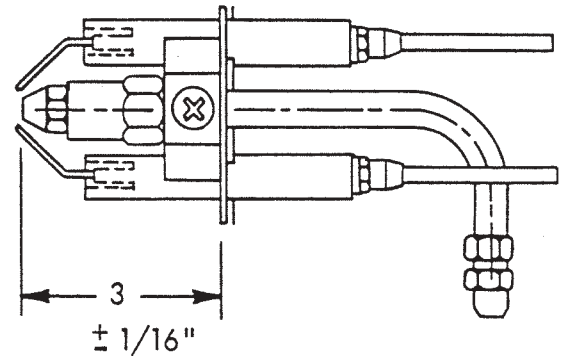
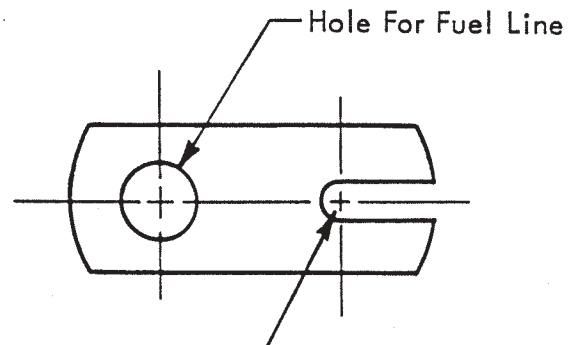


Figure 6. Burner Electrode Adjustments



Mounting Screw - slide plate against mounting screw. This will position nozzle in air tube.

Figure 7. Electrode Assembly Installation

# PREPARING FOR OPERATION

## Burner Air Band Settings

1. Close bulk air band (outside diameter band).
2. Set end air band between 3.5–4.0 on scale.
3. Open covers or dampers on exhaust stacks.
4. Check initial settings of burner regulators. Approximately 1/4-inch of adjustment screw thread should be exposed. See Figure 8.

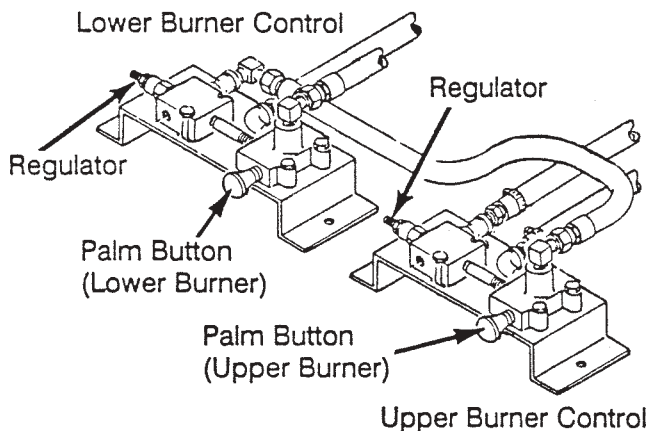


Figure 8. Burner Flow Control Regulator - Initial Adjustment

## Adjust Hydraulic System Relief Valve Setting

1. Ensure that truck parking brake is set.
2. Place truck transmission in neutral.
3. Start engine and engage PTO.
4. Adjust engine throttle to 1500 RPM.
5. Activate spray bar shift and allow spray bar to bottom out. Hold spray bar shift in this position and adjust relief valve to 1500–1975 PSI.

## Set Burner Blower Wheel Speeds

### **⚠ WARNING**

To prevent an explosion or fire hazard: Keep area free of sparks or open flames when testing burners.

1. On both burners, swing ignition transformer out of position so that blower wheel is visible.
2. Set engine throttle to 1500 rpm.

3. At system control box in cab, switch power on.
4. On burner control panel at rear of unit, pull Master Power palm button switch out.
5. On hydraulic control assembly, pull out palm button for lower burner and immediately check for the following:
  - a. Is blower wheel turning? If not check as follows:
    1. Check for hydraulic leakage and correct as necessary.
    2. Carefully place a screwdriver on outside diameter of blower wheel and attempt to start blower wheel manually.

### **⚠ CAUTION**

*Blower wheel may accelerate rapidly.*

3. Check for hydraulic flow from dump valve to burner hydraulic control assembly, to burner motor, and check return flow back to hydraulic tank.
- b. Is there any fuel coming out where fuel line is disconnected from burner nozzle?
  1. Check electrical operation of solenoid valve. Solenoid valve should be normally closed, and open when energized.
  2. Check for sticking solenoid valve.
6. Refer to Fuel Oil Pressure Gauge. Fuel oil pressure should build within 1–1/2 minutes. If fuel oil pressure does not start to build within 1–1/2 minutes, shutdown system and check all fuel system fittings for tightness or leakage.
7. On hydraulic control assembly pull out palm button for upper burner and immediately repeat steps 5. to 6. above. When satisfied that fuel oil pressure is correct and that blower wheel is operating properly, proceed as follows:
8. Run both burners hydraulically until hydraulic oil temperature in reservoir reaches 145–150° F. When hydraulic oil has reached this temperature, turn burners on and off approximately 10 times (both hydraulically and electrically) and check stability of system.

# PREPARING FOR OPERATION

**NOTE:** An RPM indicator will be required to check burner speeds.

9. With upper burner running hydraulically, set lower burner speed to 3450–3475 RPM. Then set upper burner speed to 3450–3475 RPM.
10. Shut down system and reconnect fuel line to burner assembly.

## Check Ignition Transformer Spark

1. Shut off hydraulic pressure to burners.
2. Pull out Master palm button on burner control box.
3. Hold an insulated screwdriver approximately 1 to 1-1/2 inches above the two wire springs on the transformer and hold the Ignition switch down. It should be possible to jump a spark across the 1 to 1-1/2 inch gap between the springs and the screwdriver. If unable to generate a spark, check the voltage at terminal spades of the 12-volt ignition control box. Voltage must be 110 volts AC minimum. If voltage is incorrect or not present, check ground wiring.
4. Reposition ignition transformer and secure to burner housing.

## Fire Burners

1. Ensure that fuel oil pressure is 100 PSIG.

### **⚠ WARNING**

**To prevent an explosion or fire hazard: Flues must be covered by a minimum 6 inches of material when burners are in operation. When testing burners, do not run burners for more than 15 seconds if tank is empty.**

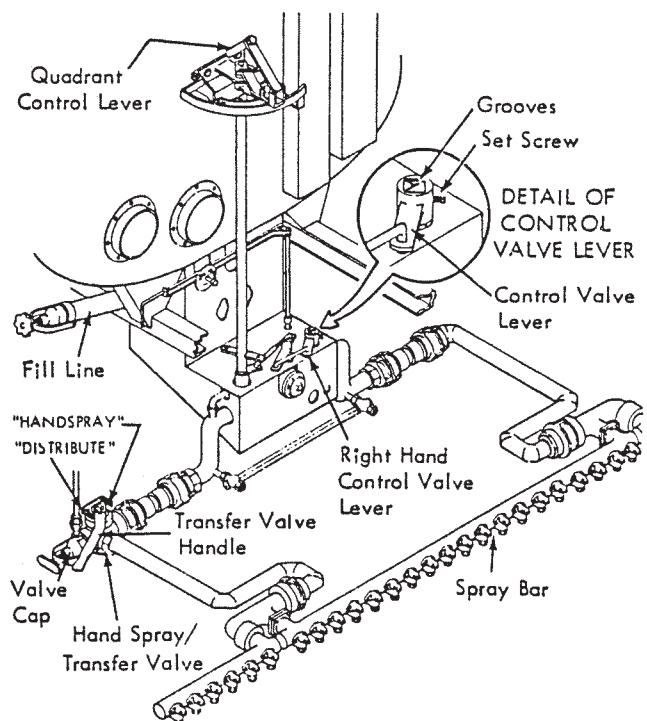
2. Hold ignition switch down until ignition occurs, and keep switch down for an additional 2 to 4 seconds before releasing.
3. Run burner for 15 seconds maximum, then shut down.

## CALIBRATING DISTRIBUTOR

**NOTE:** Do not attempt these procedures until you are familiar with all operating procedures for the distributor.

1. With product (liquid) in the distributor tank, weigh and record the weight of the unit.
2. Start with all controls set for the filling operation.

3. Locate the arm (lever) with the square socket welded to it that is attached to the top of the right hand control valve (see Figure 9.).
4. Loosen the set screw in the square socket end of the arm and lift the socket off the valve.
5. The square top of the control valve has grooves cut from the center to three corners, and will look like the illustration shown in Figure 10. when the socket is removed.



**Figure 9. Distributor Controls**

6. Use a 12" adjustable wrench to rotate the valve 180° as shown in Figure 10.



**Figure 10. Setting Control Valve While Calibrating**

7. Connect the pump off-line to the Hand Spray Transfer Valve and to a container that will be sufficient to hold the material being pumped off.

# PREPARING FOR OPERATION

8. Move the Transfer Valve handle from the Distribute position to the Hand Spray position (valve handle pointing straight back) as shown in Figure 9.
9. Adjust the asphalt pump tachometer to the desired gallons per minute (GPM).
10. Move the Intake Valve lever to the down position and immediately start timing the discharge.
11. At the end of the predetermined time period, move the Intake Valve lever to the up position. Remove the fill line cap to allow air to clear the discharge line.
12. Stop the asphalt pump.
13. Move the Quadrant Control Lever to the Fill position.
14. Move the Transfer Valve lever to the Distribute position.
3. The shoulder bolts that connect the bar extension control link to the center control link should center on the extension hinge when the valves are in the OFF position.
4. If any discrepancy is found in the preceding, correct by completing the following spray bar nozzle valve adjustment procedure.
  - a. Disconnect main control linkage and both center linkages from the center fulcrum lever.
  - b. Align left side center bolt to center of extension hinge. A rod inserted through the shoulder bolt hole to the extension hinge will aid in checking alignment. If necessary, heat and bend bar extension control link to obtain proper alignment. Verify proper alignment by raising bar with rod or shoulder bolt in place (nozzle valves should not move).
  - c. Check for proper nozzle valve lever travel on center section extension and any additional extensions. The valve levers should move 45° to the left of vertical and 40–45° to the right of vertical. Adjust if necessary.
  - d. Connect left center control linkage and adjust for proper left center section nozzle valve lever travel.
  - e. Repeat steps (b), (c) and (d) above for the right side of the bar.
  - f. Finally, at main control linkage, adjust relationship of nozzle valve lever position to Quadrant Control Lever position, per step 1.

## WARNING

To prevent burns: Always wear insulated gloves when handling spray bar sections or hoses.

15. Disconnect the discharge hose. Install caps on the fill line and transfer valve.
16. Return the right-hand control valve to its original position and re-attach the lever and linkage.
17. Re-weigh the unit and compute the gallons of material pumped off.
18. Flush the asphalt pump with clean diesel fuel.

## SPRAY BAR VALVE ADJUSTMENT

### “FC” Bar

1. The nozzle valve levers should be 40° to the right of vertical when the Quadrant Control Lever is in the “Circulate in Bar” position, and 45° to the left of vertical when the Quadrant Control Lever is in the “Distribute” position.
2. The nozzle valve levers should start to move when Quadrant Control Lever is moved 1 inch or less. If more movement of the Quadrant Control Lever is required to start nozzle valve lever movement, the linkage is worn and should be replaced.

## CAUTION

*To prevent possible damage to equipment, do not fold extensions when valves are turned on. Do not attempt to spray center of bar with extensions folded without removing shoulder bolts controlling extensions.*

### “TUC” Bar

1. Fold extensions back and adjust control linkage in center section so that valve levers are vertical when Quadrant Control Lever is 1 inch to left of 45 degree position.
2. Move Quadrant Control Lever to left and right against stops and check movement of nozzle valve levers. Nozzle valve levers should turn through approximately 30° to right of vertical and 40° to left.



## PREPARING FOR OPERATION

3. Work extension nozzle valves to check for binding, then move valve levers 30° to right of vertical (off position). Turn Quadrant Control Lever to extreme left (Circulate in Bar) position. Return extensions to the forward straightened position. The adjustable connecting chains on the upper left and lower right should become tight but should not cause movement of the extension valve levers. If movement occurs or chains are not tight, make the corresponding adjustment having first disconnected the chains on the lower left and upper right.

4. Move Quadrant Control Lever to spray position and extension valve levers to 40° left of vertical. In this position the lower left and upper right chains should be tight. Since the lever arms operating the chains are of different lengths, the lower left and upper right will be loose when the valves are thrown to the "Circulate in Bar" position, and the upper left and lower right will be loose in the "Distribute" position.

When adjusted following above instructions, valves should work easily and there should be no overload on the chain pins.

# FILLING INSTRUCTIONS

## FILLING DISTRIBUTOR THROUGH FILL LINE

### ⚠ WARNING

To prevent possible burns from foaming or violent eruption, do not load tank with material temperature over 200° F if water or condensation is present in tank, or if emulsion was used in the previous load. Clean and thoroughly drain tank first. If water or emulsion may be present in spray bar or circulating system, allow a small amount of hot material to circulate in bar BEFORE filling tank. Do not heat material over 200° if moisture or emulsion is present in tank.

To prevent possible burns from material overflow, allow sufficient space in tank for expansion of material when heating.

### ⚠ WARNING

To prevent possible burns from leaking material, be sure all pipe, cap and hose connections are secure before opening valves.

2. Ensure that all connections between distributor and supply source are tight. Air leaks will reduce vacuum and slow down filling operation.

**NOTE:** When connecting to tank car, connect 3-way valve to tank car coupling and then connect inlet hose to 3-way valve. You can then shut off tank car supply from underneath and allow pump suction to clean bitumen from hose by drawing air through vent in 3-way valve.

3. Set the operating valves and levers as shown in Figure 11.

## Connections and Preliminary Checks

1. Ensure that both the fill line and discharge strainers are clean and properly installed.

**NOTE:** On units built before 1960, move intake valve lever to the right.

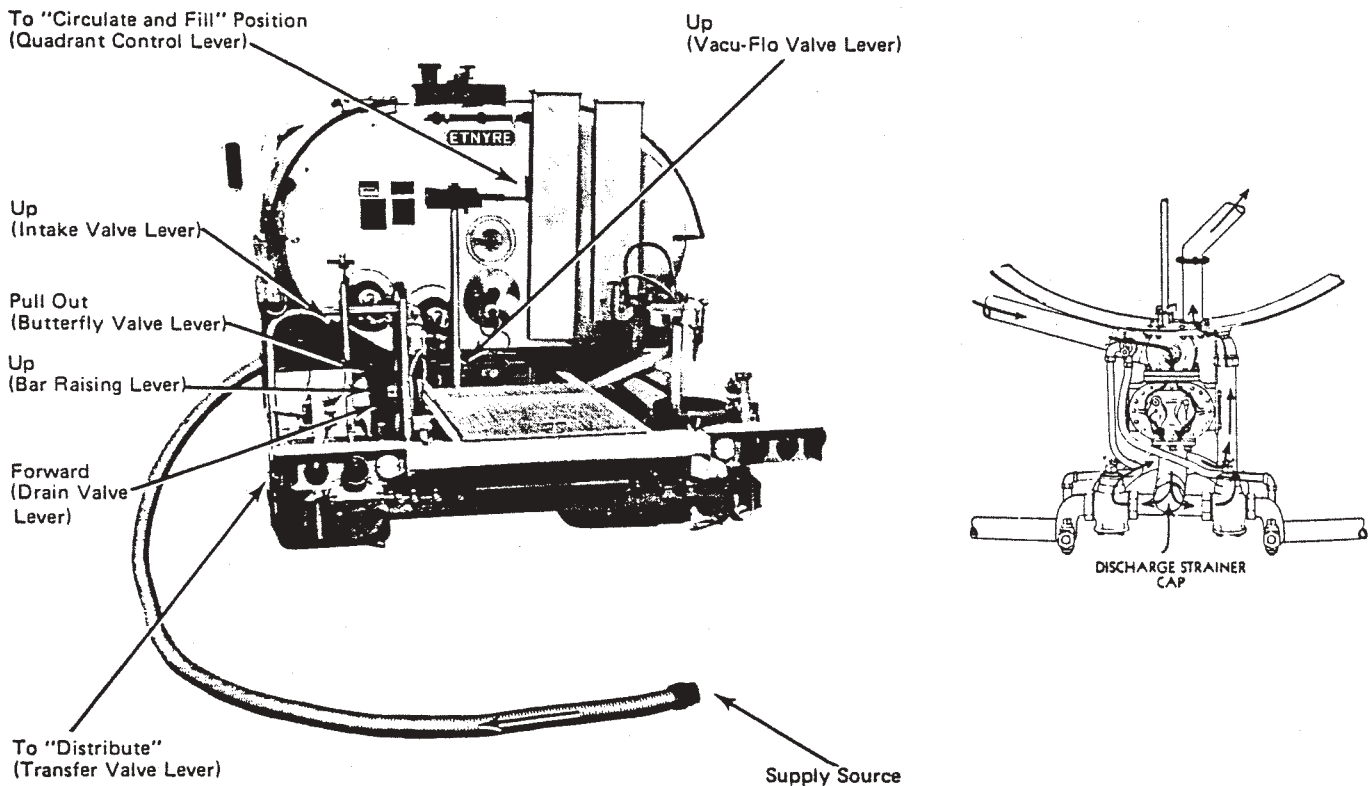


Figure 11. Filling From Supply Source

# FILLING INSTRUCTIONS

## Preheating

### WARNING

To prevent an explosion or fire hazard: Do not heat material beyond the manufacturer's recommended temperature.

### CAUTION

To prevent possible damage to equipment from material setting up in hose or distributor, ensure that bitumen in supply tank is heated sufficiently.

To prevent possible equipment damage, do not try to break loose a frozen pump on engine-driven models by slipping or sudden engagement of clutch.

If pump, spray bar and/or circulating system were not drained and flushed after previous use, heat all systems thoroughly before attempting to start pump. When handling heavier bitumens, it may be necessary to preheat the circulating system to ensure that the first material to enter the pump will not stop the pump.

**NOTE:** A portable burner is available to preheat the circulating system. An opening is provided at the lower-rear of the circulating system housing for the burner.

On units equipped with engine exhaust heating it is possible to heat the pump and circulating system with hot exhaust gases. This is accomplished by positioning the butterfly valve on the exhaust pipe to the HEATING position. It is recommended that the valve be returned to the normal EXHAUST position after sufficient heating has been accomplished.

If Distributor is to be filled with hot bitumen, proceed cautiously. If there is any moisture in the tank, or if emulsion was used in the previous load foaming or eruption may occur.

**NOTE:** Dow-Corning DC-200 may be used to prevent foaming. One ounce of DC-200 should be adequate for 1000 gallons of asphalt. Additional DC-200 may be obtained from E.D. Etnyre & Co.

## Engaging Pump

### Engine-Driven Models

### WARNING

To prevent becoming entangled in machinery, stand clear of rotating drives.

1. Start engine and set at fast idle.
2. Shift transmission to low gear and engage clutch carefully.
3. Adjust pump speed by adjusting engine governor control.

### Hydrostatic Models

### WARNING

To prevent becoming entangled in machinery, stand clear of rotating drives.

### CAUTION

To prevent damage to the asphalt pump, do not run pump for more than 10 minutes without bitumen to supply lubrication.

1. Push in override control located at rear platform.
2. Pull up on cab hydraulic control knob.
3. Start truck engine with transmission in neutral and engage PTO. Increase engine RPM to fast idle.

On trucks with manual transmission, depress the clutch and pull outward or upward on the PTO control knob. If the PTO fails to engage, gently allow the clutch pedal upward until engagement occurs.

On trucks with automatic transmission, push down on the foot brake pedal, move the gear selector to any forward gear and pull upward or outward on the PTO control knob. When PTO engages move gear selector to neutral.

# FILLING INSTRUCTIONS

**NOTE:** *If the PTO fails to engage, continue pulling on the knob while releasing the brake pedal sufficiently to allow the truck to inch forward until the PTO engages, then move the gear selector back to neutral.*

4. Ensure that truck parking brake is engaged before exiting cab.
5. Push down on hydraulic control knob until desired GPM is reached. If the stop is set on the hydraulic control knob for a given application rate, the rear override control may be used to increase the pump speed. Always release the rear override before preceding to the next pumping operation.
6. To adjust pump speed, pull out override control for desired pump speed.

**NOTE:** *Insufficient pump speed may require an increase in truck engine RPM.*

## Pumping

### **⚠ WARNING**

To prevent possible burns from material overflow, allow sufficient space in tank for expansion of material when heating.

1. Operate the pump at the maximum speed where it will run quietly. Higher speeds will not load thick material fast. Normally 150 GPM is the best loading speed. Light materials, or heavy materials at spraying temperature, may be loaded at faster pump speeds (maximum 240 GPM).

### **⚠ WARNING**

To prevent an explosion or fire hazard: Keep burning cigarettes or other sources of combustion away from manholes and overflow vents.

2. Open the valve at the supply source and monitor the tank gauge. When the gauge shows half-full, position someone at the manhole to advise the person at the supply source when to close the valve. For safety reasons there should always be two people acting together during the filling operation.
3. After closing off the supply tank valve, open the bleeder valve (at the supply) to assist in sucking residual product out of the fill line before disconnecting the hose from either the supply source or the distributor fill line.

### **⚠ WARNING**

To prevent burns, always wear insulated gloves when handling spray bar sections or hoses.

**NOTE:** *If there is no bleeder valve at the supply source, carefully break the connection between the valve and the fill hose to allow air into the hose.*

4. Increase the pump speed to 200 GPM, disconnect the hose at the supply end and elevate the hose to allow maximum drainage to the fill line.
5. Allow the pump to continue turning while the hose is disconnected from the fill line and the fill line cap is replaced and secured.

## FILLING DISTRIBUTOR THROUGH MANHOLE

### **⚠ WARNING**

To prevent possible injury, always open manhole cover slowly. Pressure build-up in tank may cause cover to burst open.

To prevent an explosion or fire hazard: Keep burning cigarettes or other sources of combustion away from manholes and overflow vents.

To prevent possible burns from foaming or violent eruption, do not load tank with material temperature over 200° F if water or condensation is present in tank, or if emulsion was used in the previous load. Do not heat material over 200° if moisture or emulsion is present in tank.

To prevent possible burns from material overflow, allow sufficient space in tank for expansion of material when heating.

### **⚠ CAUTION**

To prevent possible damage to equipment, always use manhole strainer when filling through manhole.

If product being fed through manhole is in excess of 200° F, and you suspect there may be moisture or emulsion in the tank, Dow-Corning DC-200 may be used to prevent foaming. One ounce of DC-200 concentrate should be adequate for 1000 gallons of asphalt. Additional DC-200 may be obtained from E.D. Etnyre & Co.

## FILLING INSTRUCTIONS

If no foaming occurs at the start of the filling operation but you suspect there may be moisture in the circulating system or spray bar, it is recommended the filling operation be stopped when the tank is no more than 25 percent full. The product should then be circulated through the spray bar at 80 to 110 GPM before continuing the filling operation. (Refer to Page 38 for instruction on spray bar circulation.)

If foaming occurs, continue circulating until foaming stops, then suck the product in the spray bar back into the tank before filling the tank the rest of the way (see Page 43).

If you do not want material to enter pump and circulating system, place intake valve lever in extreme UP position. On units with inside closing valve (operated by handwheel on top of tank), close valve by turning wheel fully clockwise.

# HEATING BITUMEN IN DISTRIBUTOR

## LIQUID PROPANE GAS (LPG) BURNERS

### **⚠ DANGER ⚠**

To avoid an extreme fire hazard or explosion, NEVER use gasoline as fuel in high pressure generating burners or low pressure atomizing burners.

### **⚠ WARNING**

To prevent an explosion or fire hazard: Do not operate burners if tank is damaged or leaking.

To prevent an explosion or fire hazard: When burners go out, allow flues to ventilate for several minutes before re-lighting burners.

### **⚠ WARNING**

Residual fuel in LPG burners will support a flame for several minutes after the fuel flow has been shut off. After using LPG burners, confirm that all flame has been extinguished before attempting any operation that could release flammable vapors.

Failure to ensure that the flame is completely extinguished could result in an explosion or fire that can cause injury or death.

### **⚠ WARNING**

A fully charged dry chemical type fire extinguisher must be within easy reach whenever the burners are operating or there is an open flame near the distributor. Minimum dry chemical capacity of the fire extinguisher should be 10 pounds.

To prevent an explosion or fire hazard: Do not heat material beyond the manufacturer's recommended temperature.

To prevent foaming or violent eruption, do not heat material over 200° if moisture or emulsion is present in tank.

To prevent possible burns from material overflow, allow sufficient space in tank for expansion of material when heating.

To prevent possible hand or facial burns, always light inside burner first. Do not reach across a lit burner to light (or re-light) inside burner. Shut off outside burner before lighting inside burner.

To prevent possible burns, always use a torch to light burners. Never attempt to light burners with a match or pocket lighter.

### **⚠ WARNING**

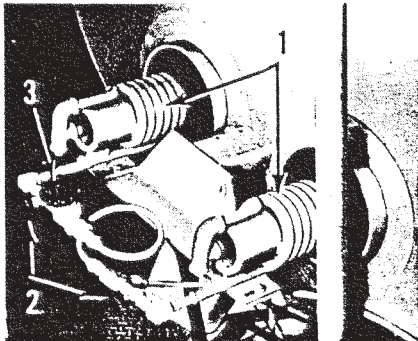
To prevent an explosion or fire hazard: Position unit broadside to wind whenever possible to prevent volatile fumes from drifting toward burners.

To prevent an explosion or fire hazard: Flues MUST be covered by a minimum 6 inches of material when burners are in operation.

To prevent an explosion or fire hazard: Do not remove material from tank in any manner when burners are in operation.

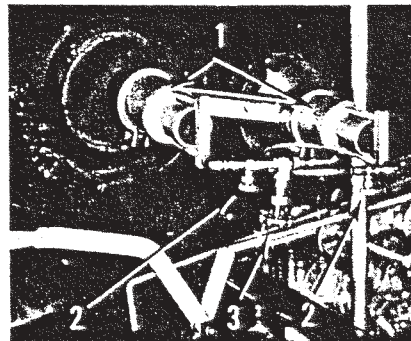
# HEATING BITUMEN IN DISTRIBUTOR

## LIQUID PROPANE GAS (LPG) BURNERS



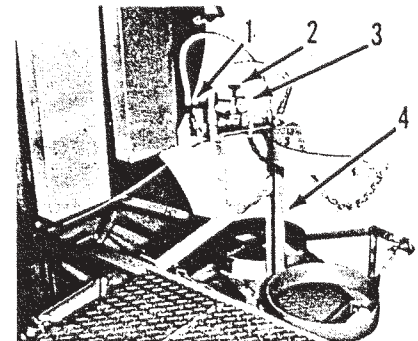
LIQUID PETROLEUM BURNERS (A)

1. Burners
2. Blow and Pilot Hand Valve
3. Auxiliary Shut-off Hand Valve



LIQUID PETROLEUM BURNERS (B)

1. Burners
2. Blow and Pilot Hand Valves
3. Auxiliary Shut-off Hand Valve



LIQUID PETROLEUM BOTTLE RACKS AND CONTROLS

1. Manual Throwover Manifold Valve
2. Burner Pressure Regulator Control
3. Regulated Pressure Gauge
4. Bottle Rack

Figure 12. LPG Burners

### IMPORTANT

Circulating bitumen in the tank while heating is recommended for faster heating and reduced carbon on flues. Only when the asphalt pump is “frozen” is it acceptable to operate burners without circulating material. However, if the asphalt pump is frozen, carefully apply heat to the pump housing and start circulating material as soon as possible.

### LPG SUPPLY TANK REQUIREMENTS

Use only liquid withdrawal type supply tanks for your LPG burners!

Two types of LPG supply tanks are available: tanks for liquid-type burners and tanks for vapor-type burners. The LPG burners on your Etnyre equipment require a supply tank equipped for liquid-type burners. Liquid type burners will operate from a vapor withdrawal tank, however, the amount of heat delivered will be dramatically reduced, and the life of the burner will be greatly decreased.

This section will cover three types of LPG burners: manual control burners, burners with outfire control, and burners with automatic ignition and temperature limiting control.

### MANUAL CONTROL BURNERS

#### Burner Control Valves

There are four valves associated with operation of the manual control burners: one at the supply tank and three in the burner piping.

The two smaller valves (one at each burner) are bleeder type valves with a small hole drilled through the valve case that bypasses the main cut off. It is not possible to completely cut off all fuel flow to the burners with these valves.

The large valve located in the fuel line to the outside (or upper) burner is a positive cutoff valve that allows all fuel to be cut off to the bleeder valve on the outside burner. The only way to completely stop fuel flow to the inside burner is to close the main supply valve at the fuel supply tank.

#### Burner Operation

1. Ensure that all burner control valves are fully closed before starting.
2. Open the covers on the heat exhaust stacks.
3. Open the valve at the supply tank and quickly check for leaks. If no leaks are found light the inside burner. As soon as the flame is established open the bleeder valve fully. No preheating is necessary.

# HEATING BITUMEN IN DISTRIBUTOR

## LIQUID PROPANE GAS (LPG) BURNERS

### ⚠ WARNING

To prevent possible burns, always use a torch to light burners. Never attempt to light burners with a match or pocket lighter.

A fully charged dry chemical type fire extinguisher must be within easy reach whenever the burners are operating or there is an open flame near the distributor. Minimum dry chemical capacity of the fire extinguisher should be 10 pounds.

### IMPORTANT

It is recommended that two persons be involved in lighting the first burner. When the main fuel valve is opened at the bottle or tank, there is an immediate trickle of gas passing through the inside burner bleeder valve. The longer the gas is allowed to collect in the flue, the more likely there will be a flashback when the burner is ignited. Having one person light the burner while the other opens the main supply valve will reduce the likelihood of a flashback.

4. Check the fuel pressure at the pressure regulator. Too much fuel pressure for a small tank will waste fuel. Too little fuel pressure on a large tank will increase heating time. Some experimentation with pressures will allow you to determine the most efficient fuel pressure to use. The following is a good rule of thumb:

1000 - 1250 gallon tank:	15 PSI
1500 - 1750 gallon tank:	20 PSI
2000 - 2250 gallon tank:	25 PSI
2250 - 2500 gallon tank:	30 PSI
2750 - gallon and larger	40 PSI

5. If necessary, adjust the flame with the bleeder valve at the burner.

When the LPG burners are operating, the outside of the fuel line up to the first coil of the burner should frost over. If no frost forms it is an indication that the burners are operating on vapor instead of liquid. This condition must be corrected immediately to prevent damage to the burners.

If after the lines frost over, the flame starts to die down and the frost melts off the fuel line, it is likely there is moisture in the fuel supply tank. When the moisture passes through the frost covered lines it forms ice crystals that stop the fuel flow. This can be overcome by adding 1 pint of 99.85% pure Genuine Anhydrous Methanol when the tank is filled with fuel. Keeping the tank valve closed when the tank is empty will keep moisture from entering the tank.

**NOTE:** *If there is at least 6 inches of product covering the entire length of the upper flue the second burner can be ignited.*

### ⚠ WARNING

To prevent possible burns, always use a torch to light burners. Never attempt to light burners with a match or pocket lighter.

6. To ignite the second burner ensure the bleeder valve on the burner is closed. Position a torch at the burner nozzle and open the positive shut off valve in the line to the burner. As soon as the low fire is established the bleeder valve can be opened fully.
7. Monitor the product temperature. When the desired temperature is reached, **CLOSE THE MAIN FUEL SUPPLY VALVE AT THE BOTTLE OR TANK FIRST.** Allow the burners to operate at full capacity until the fuel in the line from the bottle burns out, then close both bleeder valves and the positive shut off valve at the burners.
8. Close the exhaust stack covers to prevent heat loss and to prevent water from entering the stacks.

## BURNERS WITH OUTFIRE CONTROL

### Equipment Design

The burner mounting and the burner control valves are identical to the manual operated burner system. However, burners with outfire control are equipped with an outfire control box. The outfire controls consist of two thermocouple switches, a push button start switch, an electric fuel solenoid valve, a pressure regulator and a pressure gauge.

A heat sensing probe is positioned in each burner. These probes are connected to the thermocouple switches by a capillary tube. If either burner loses flame, the probe senses the reduced temperature, the thermocouple switch activates the fuel solenoid, and all fuel to both burners is cutoff.



# HEATING BITUMEN IN DISTRIBUTOR

## LIQUID PROPANE GAS (LPG) BURNERS

The only difference in operation between manual burners and burners with optional outfire control is the start-up and shut-down procedures. Unlike the manual burners, when the burners are equipped with outfire control no fuel flows to the burners when the main fuel supply valve is opened.

### Operation

**NOTE:** *It is recommended that two persons be involved in lighting the burners. One person should hold the torch while the other person opens the valves and holds the pushbutton in.*

1. Open the covers on the heat exhaust stacks.
2. Ensure that all three burner control valves are closed.
3. Open the main fuel supply valve at the tank.

### IMPORTANT

Both burners must be lit on low flame even if only one burner will be used for heating.

### ⚠ WARNING

A fully charged dry chemical type fire extinguisher must be within easy reach whenever the burners are operating or there is an open flame near the distributor. Minimum dry chemical capacity of the fire extinguisher should be 10 pounds.

4. Place the ignition torch at the inside burner nozzle and depress the push button in the outfire control box. Continue to hold the pushbutton in until both burners are lit.
5. As soon as the low fire is established at the inside burner, open the positive shut off valve to the outside burner and light the outside burner on low fire.
6. If both burners are to be used for heating you can now open both bleeder valves fully. If only the inside burner is to be used for heating, open the bleeder valve on the inside burner and allow the outside burner to remain burning on low flame so the thermocouple will be heated. Remember, if either flame goes out the outfire control will cut off fuel to both burners.

7. After 30 to 40 seconds, release the push button and observe the pressure gauge. If the pressure starts to drop rapidly, depress the push button and hold it for another 30 seconds. It may require a slight increase in fuel to the outside burner to heat the thermocouple. Once both thermocouples are heated the push button can be released.

When the LPG burners are operating, the outside of the fuel line up to the first coil of the burner should frost over. If no frost forms it is an indication that the burners are operating on vapor instead of liquid. This condition must be corrected immediately to prevent damage to the burners.

If after the lines frost over, the flame starts to die down and the frost melts off the fuel line, it is likely there is moisture in the fuel supply tank. When the moisture passes through the frost covered lines it forms ice crystals that stop the fuel flow. This can be overcome by adding 1 pint of 99.85% pure Genuine Anhydrous Methanol when the tank is filled with fuel. Keeping the tank valve closed when the tank is empty will keep moisture from entering the tank.

8. When the desired product temperature is reached:
  - a. Close the main fuel supply valve at the bottle.
  - b. Depress the push button in the outfire box and hold it until all the fuel is burned and there is no flame at either burner.
  - c. Close both bleeder valves and the positive cut off valve at the burners.
  - d. Close the exhaust stack covers to prevent heat loss and to prevent water from entering the stacks.

### BURNERS WITH AUTOMATIC IGNITION AND TEMPERATURE LIMITING CONTROL

#### Equipment Description

The temperature limiting control box contains the temperature limiting control components as well as the automatic ignition circuitry.

The automatic ignition circuit consists of two 12-volt coils, two spark plugs, a pair of thermocouple temperature probes (one at each pilot burner), and a momentary push button switch. The 12-volt coils send high voltage to the spark plugs that cause a spark to arc intermittently at each pilot burner whenever there is fuel pressure in the line from the main supply bottle. The temperature probes provide a signal that indicates when there is a flame at the pilot burners. The momentary push button switch on the control box is used to fire the main burners once the pilot burners have ignited and the thermocouples have heated sufficiently.

# HEATING BITUMEN IN DISTRIBUTOR

## LIQUID PROPANE GAS (LPG) BURNERS

The temperature limiting control circuit consists of a temperature probe in the distributor tank that senses product temperature, a thermostatic switch in the control box, and a temperature adjustment dial on the face of the control box. When the product in the distributor is heated to the temperature selected with the temperature adjustment dial the thermostatic switch shuts down the burners.

### Burner Operation

1. Open the covers on the heat exhaust stacks.
2. Open the main fuel supply valve at the supply tank. The spark plugs will begin arcing and ignite the pilot burners.

**NOTE:** *With this type of control the inside (lower) burner may be operated without opening the positive shut off valve to the outside (upper) burner. If both burners are to be used, the positive shutoff valve to the outside burner should be opened.*

3. Allow the pilot burners to heat the thermocouple probes for a minute or two, then press the momentary push button switch to fire the main burners. The bleeder valves may then be fully opened.
4. On new or rebuilt units, monitor the product thermometers to make certain the burners shut down when the desired temperature is reached (as set

on the temperature adjustment dial). If the burners do not shut down at the correct temperature, refer to "Calibrating the Thermostat" below.

5. To shut the system down:
  - a. Close the main fuel supply valve at the supply tank.
  - b. Increase the thermostat setting 50° to 75° higher and push the start button. This will bring on the main burners and quickly burn off all the fuel in the line between the bottle and the control box. The pilot burners may continue to burn for a short while after the main burners cut off. Do not draw material from the tank as long as there is flame present.

### Calibrating the Thermostat

If the desired temperature is reached and the burners have not shut down, remove the thermostat dial. Using a small screwdriver slowly turn the screw in the center of the thermostat shaft counterclockwise until the main burners shut down.

If the main burners shut down before the desired temperature is reached, remove the dial and rotate the screw clockwise half a turn and push the start button. Monitor the thermometer and make further adjustments if needed to calibrate the thermostat.

# HEATING BITUMEN IN DISTRIBUTOR

## LOW PRESSURE ATOMIZING BURNERS

### **⚠ DANGER ⚠**

To avoid an extreme fire hazard or explosion, NEVER use gasoline as fuel in high pressure generating burners or low pressure atomizing burners.

### **⚠ WARNING**

To prevent an explosion or fire hazard: Position unit broadside to wind whenever possible to prevent volatile fumes from drifting toward burners.

To prevent an explosion or fire hazard: Flues MUST be covered by a minimum 6 inches of material when burners are in operation.

To prevent an explosion or fire hazard: Do not remove material from tank in any manner when burners are in operation.

To prevent an explosion or fire hazard: Do not operate burners if tank is damaged or leaking.

To prevent an explosion or fire hazard: Do not operate burners when vehicle is unattended, when vehicle is in motion, or with vehicle in a confined area.

To prevent an explosion or fire hazard: When burners go out, allow flues to ventilate for several minutes before re-lighting burners.

To prevent an explosion or fire hazard: Do not heat material beyond the manufacturer's recommended temperature.

To prevent foaming or violent eruption, do not heat material over 200° if moisture or emulsion is present in tank.

To prevent possible burns from material overflow, allow sufficient space in tank for expansion of material when heating.

To prevent possible hand or facial burns, always light inside burner first. Do not reach across a lit burner to light (or re-light) inside burner. Shut off outside burner before lighting inside burner.

To prevent possible burns, always use a torch to light burners. Never attempt to light burners with a match or pocket lighter.

### **⚠ WARNING**

A fully charged dry chemical type fire extinguisher must be within easy reach whenever the burners are operating or there is an open flame near the distributor. Minimum dry chemical capacity of the fire extinguisher should be 10 pounds.

### **IMPORTANT**

Circulating bitumen in the tank while heating is recommended for faster heating and reduced carbon on flues. Only when the asphalt pump is "frozen" is it acceptable to operate burners without circulating material. However, if the asphalt pump is frozen, carefully apply heat to the pump housing and start circulating material as soon as possible.

### **GENERAL INFORMATION**

The low pressure atomizing burners can burn either moisture free kerosene or Number 2 diesel fuel. The air flow used to vaporize the fuel and furnish oxygen for combustion is provided by a lobe type blower. The burner fuel pump is an integral part of the blower and provides fuel whenever the blower is operated.

The air from the blower travels through a duct to the burner air manifold. Pressure is limited by an air relief valve located on top of the air manifold. The volume of air to each of the burners is regulated by individual butterfly valves.

### **BLOWER DRIVES**

On an engine drive unit the blower drive is a jaw clutch power take-off on the two speed transmission. When engaged, the power take-off turns a V-belt that drives the blower.

On hydrostatic drive units the blower may be driven in one of two ways: by the PTO driveline or by a separate hydraulic motor.

### **PTO Driveline Units**

Units manufactured prior to 1972 (or units with a serial number lower than J-3992) have the blower mounted on a bracket or support attached to the truck frame. A pulley type clutch on the blower input shaft is used to engage and disengage the blower. A pulley adapter in the hydraulic pump drive line drives the "V" belt to the blower. The air from the blower travels through a tube to the rear of the tank where it enters the burner manifold.

# HEATING BITUMEN IN DISTRIBUTOR

## LOW PRESSURE ATOMIZING BURNERS

### Hydraulic Motor Driven Units

Hydrostatic drive units manufactured after 1972 will have the blower mounted near the rear of the tank, usually on the right side operating platform. The blower is driven by a small hydraulic motor. A variable flow diverter valve is used to direct a portion of the hydraulic fluid in the high pressure line to the hydraulic blower motor. The remainder of the fluid is used to drive the product pump drive motor. Some units manufactured after March of 1990 had an optional auxiliary pump to furnish hydraulic fluid to drive the blower motor.

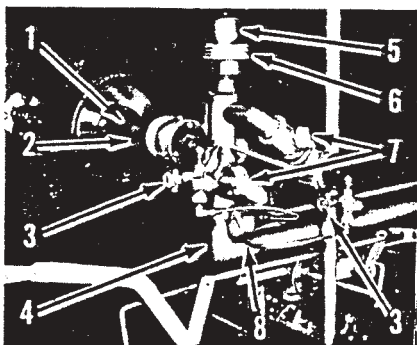


Figure 13. Low Pressure Atomizing Burners

- |                                 |                       |
|---------------------------------|-----------------------|
| 1. Burner Tip                   | 5. Air Relief Valve   |
| 2. Burner                       | 6. Weights            |
| 3. Needle Flow Valves           | 7. Butterfly Valves   |
| 4. Low Pressure Air Supply Line | 8. Air Pressure Gauge |

### BURNER OPERATION ON ENGINE DRIVEN UNITS

1. Start the engine and increase the engine speed to a fast idle.
2. If the product is hot enough to circulate, place the two speed transmission in low gear. If the product is too cold to circulate, place the transmission in neutral.
3. Engage the blower drive jaw clutch.
4. Engage the engine clutch.
5. Open the covers on the heat exhaust stacks.
6. Increase the engine speed until the pump tachometer reads approximately 120 GPM.

7. Check the fuel pressure in the supply line to the burners. The fuel pressure should be 10-15 PSI. The fuel pressure is adjusted with the Ful-Flo relief valve located at either the fuel pump or near the fuel reservoir.
8. Start with the inside or lower burner first. On older units where both burners are located on the same level, start the burner on the right side first.

### ⚠ WARNING

To prevent possible burns, always use a torch to light burners. Never attempt to light burners with a match or pocket lighter.

A fully charged dry chemical type fire extinguisher must be within easy reach whenever the burners are operating or there is an open flame near the distributor. Minimum dry chemical capacity of the fire extinguisher should be 10 pounds.

### ⚠ WARNING

To prevent possible hand or facial burns, always light inside burner first. Do not reach across a lit burner to light (or re-light) inside burner. Shut off outside burner before lighting inside burner.

9. Adjust the air butterfly valve on the burner to the number 2 or 3 position (or to the area marked start). Hold the lighted torch along side the burner near the front and open the fuel valve until the burner fires. If the smoke from the exhaust stack is dark, start opening the butterfly valve until the exhaust gas is a light grey, then gently increase the fuel flow and the butterfly valve alternately so you maintain a slight color to the exhaust gases. When the butterfly is fully open the color of the exhaust gas is controlled by increasing or decreasing the fuel.
10. Once the first burner is burning satisfactorily, the second burner can be ignited in the same manner as long as the flue surface is covered over its entire length by a minimum of 6 inches of product.

Monitor the temperature of the product while heating. When the desired temperature is reached, close the burner fuel valves, disengage the blower drive and close the exhaust stack cover(s) to prevent heat loss and to prevent water from entering the stacks.

# HEATING BITUMEN IN DISTRIBUTOR

## LOW PRESSURE ATOMIZING BURNERS

### BURNER OPERATION ON HYDROSTATIC UNITS

#### Units With PTO Blower Drive

1. Open the covers on the heat exhaust stacks.
2. With the truck transmission in neutral start the truck engine and engage the PTO.

**NOTE:** *If the product is too cold to circulate leave the intake valve closed.*

3. Engage the drive belt clutch on the blower shaft.
4. Open both burner butterfly valves fully clockwise.
5. Increase the truck engine speed until the air pressure relief valve on the burner manifold raises approximately 1/4 inch from its fully closed position and lock the hand throttle at that point.
6. Proceed as described in paragraphs 7. through 10. under "Engine Driven Units" above.

### Hydraulic Motor Driven Units

1. Open the covers on the heat exhaust stacks.
2. Start the truck engine and engage the PTO.
3. Increase the truck engine to about 1500 RPM and lock the hand throttle.
4. Adjust the pump tachometer to read approximately 200 GPM.
5. Open both burner butterfly valves fully clockwise.
6. Rotate the knurled knob on the blower motor control valve until the air pressure relief valve on the burner manifold raises approximately 1/4 inch from its fully closed position.
7. Proceed as described in paragraphs 7. through 10. under "Engine Driven Units" above.

# HEATING BITUMEN IN DISTRIBUTOR

## HIGH PRESSURE FUEL OIL BURNERS

### **⚠ DANGER ⚠**

To avoid an extreme fire hazard or explosion, NEVER use gasoline as fuel in high pressure generating burners or low pressure atomizing burners.

### **⚠ WARNING**

To prevent an explosion or fire hazard: Position unit broadside to wind whenever possible to prevent volatile fumes from drifting toward burners.

To prevent an explosion or fire hazard: Flues MUST be covered by a minimum 6 inches of material when burners are in operation.

To prevent an explosion or fire hazard: Do not remove material from tank in any manner when burners are in operation.

To prevent an explosion or fire hazard: Do not operate burners if tank is damaged or leaking.

To prevent an explosion or fire hazard: Do not operate burners when vehicle is unattended, when vehicle is in motion, or with vehicle in a confined area.

To prevent an explosion or fire hazard: When burners go out, allow flues to ventilate for several minutes before re-lighting burners.

To prevent an explosion or fire hazard: Do not heat material beyond the manufacturer's recommended temperature.

To prevent foaming or violent eruption, do not heat material over 200° if moisture or emulsion is present in tank.

To prevent possible burns from material overflow, allow sufficient space in tank for expansion of material when heating.

To prevent possible hand or facial burns, always light inside burner first. Do not reach across a lit burner to light (or re-light) inside burner. Shut off outside burner before lighting inside burner.

### **⚠ WARNING**

To prevent possible burns, always use a torch to light burners. Never attempt to light burners with a match or pocket lighter.

A fully charged dry chemical type fire extinguisher must be within easy reach whenever the burners are operating or there is an open flame near the distributor. Minimum dry chemical capacity of the fire extinguisher should be 10 pounds.

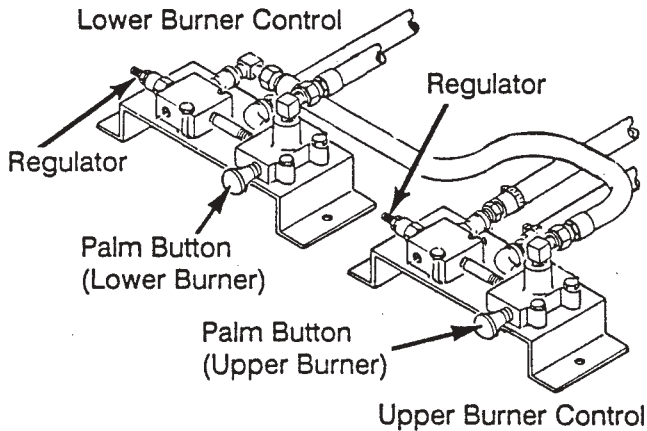
### **IMPORTANT**

Circulating bitumen in the tank while heating is recommended for faster heating and reduced carbon on flues. Only when the asphalt pump is "frozen" is it acceptable to operate burners without circulating material. However, if the asphalt pump is frozen, carefully apply heat to the pump housing and start circulating material as soon as possible.

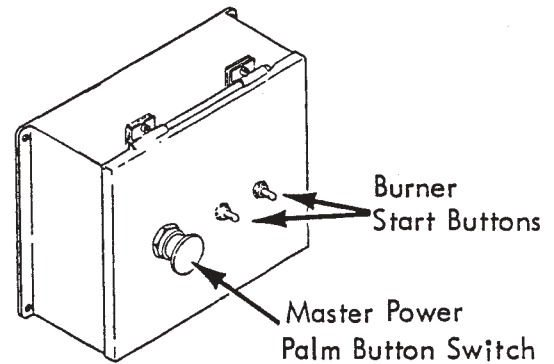
1. Set truck parking brake.
2. Open covers on heat exhaust stacks.
3. Place truck transmission in neutral.
4. Engage PTO (if so equipped).
5. Set engine throttle at 1500 RPM.
6. Pull out palm button on lower burner hydraulic control valve located in tool box (see Figure 14.).
7. If upper burner operation is desired pull out palm button on upper burner hydraulic control valve located in tool box (see Figure 14.).
8. Pull out Master Power palm button switch located on burner control panel at rear of unit (see Figure 15.).
9. To light lower burner, push lower burner START button on burner control panel.
10. If upper burner operation is desired, push upper burner START button on burner control panel.

# HEATING BITUMEN IN DISTRIBUTOR

## HIGH PRESSURE FUEL OIL BURNERS

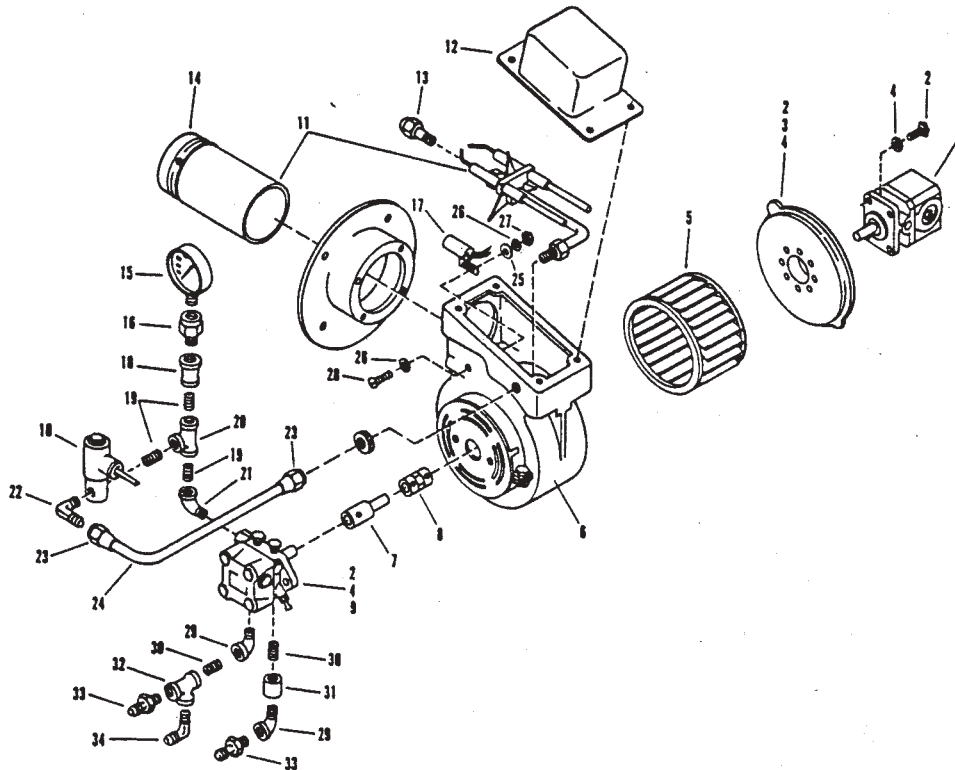


**Figure 14. Burner Hydraulic Control Valves**



**Figure 15. Burner Control Panel**

11. To shut down burner(s) push in Master Power palm button switch.
12. Push in hydraulic control valve palm button(s).
13. When burners are not in use, close the exhaust stack covers to prevent heat loss and to prevent water from entering stacks.



**Figure 16. Burner Assembly**

# HEATING BITUMEN IN DISTRIBUTOR

## HIGH PRESSURE (KEROSENE) GENERATING BURNERS

### DANGER

To avoid an extreme fire hazard or explosion, NEVER use gasoline as fuel in high pressure generating burners or low pressure atomizing burners.

### WARNING

To prevent an explosion or fire hazard: Position unit broadside to wind whenever possible to prevent volatile fumes from drifting toward burners.

To prevent an explosion or fire hazard: Flues MUST be covered by a minimum 6 inches of material when burners are in operation.

To prevent an explosion or fire hazard: Do not remove material from tank in any manner when burners are in operation.

To prevent an explosion or fire hazard: Do not operate burners if tank is damaged or leaking.

To prevent an explosion or fire hazard: Do not operate burners when vehicle is unattended, when vehicle is in motion, or with vehicle in a confined area.

To prevent an explosion or fire hazard: When burners go out, allow flues to ventilate for several minutes before re-lighting burners.

To prevent an explosion or fire hazard: Do not heat material beyond the manufacturer's recommended temperature.

To prevent foaming or violent eruption, do not heat material over 200° if moisture or emulsion is present in tank.

To prevent possible burns from material overflow, allow sufficient space in tank for expansion of material when heating.

To prevent possible hand or facial burns, always light inside burner first. Do not reach across a lit burner to light (or re-light) inside burner. Shut off outside burner before lighting inside burner.

To prevent possible burns, always use a torch to light burners. Never attempt to light burners with a match or pocket lighter.

### WARNING

A fully charged dry chemical type fire extinguisher must be within easy reach whenever the burners are operating or there is an open flame near the distributor. Minimum dry chemical capacity of the fire extinguisher should be 10 pounds.

### IMPORTANT

Circulating bitumen in the tank while heating is recommended for faster heating and reduced carbon on flues. Only when the asphalt pump is "frozen" is it acceptable to operate burners without circulating material. However, if the asphalt pump is frozen, carefully apply heat to the pump housing and start circulating material as soon as possible.

To ensure efficient operation, use only clean, moisture-free kerosene.

**NOTE:** A vaporizing plug sized for diesel fuel is available, but diesel fuel is difficult to generate and once generated it is more difficult to maintain generation. Another drawback to using diesel is the accelerated formation of carbon inside the coils of the burner.

1. Set truck parking brake.
2. To operate the fuel pump on engine-driven units:
  - a. Disengage engine clutch.
  - b. Engage fuel pump clutch.
  - c. If the product can be circulated, place the transmission in low gear. If the product is too cold to be circulated, place the transmission in neutral.
  - d. Engage the engine clutch and increase engine speed to 1/2 throttle. If the transmission is engaged, adjust the engine throttle to obtain approximately 100-120 GPM on the pump tachometer.

**NOTE:** On hydrostatic units the fuel pump is driven off the hydrostatic pump drive line, and requires no manual engagement.

3. Correct fuel pressure should be between 45-60 PSI.

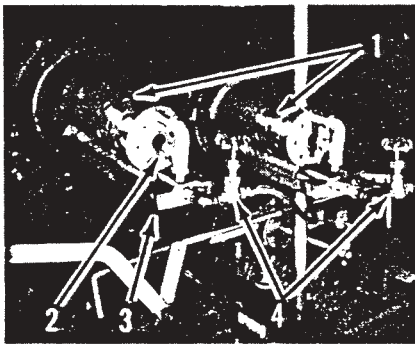
**NOTE:** If fuel pressure is low, inspect fuel system components for leaks or possible obstructions. If fuel pump is getting sufficient fuel, check and adjust fuel pressure relief valve as necessary. An adjusting screw with lock nut is located inside the dome-shaped cap.



# HEATING BITUMEN IN DISTRIBUTOR

## HIGH PRESSURE (KEROSENE) GENERATING BURNERS

4. Remove retaining pins that hold burners inside flues and pull burners out of flues.
5. Open covers on heat exhaust stacks.
6. Light burners as follows:
  - e. Spread wick in pan so that fire will be under coil and vaporizing plug (see Figure 17.).
  - h. Light the wick and watch the burner nozzle. As the coil gets hot the fuel in the coil will expand and spurt from the nozzle. When the raw fuel stops spurting and an almost colorless gas is seen coming out of the nozzle, open the fuel valve very slowly until a bushy, yellow to bright orange flame is obtained.



**Figure 17. High Pressure (Kerosene) Generating Burners**

- |                    |                               |
|--------------------|-------------------------------|
| 1. Burners         | 3. Pan                        |
| 2. Vaporizing Plug | 4. Flow Control Needle Valves |

- f. Place a flat piece of cardboard or metal against the front of the lower burner coil and open the fuel valve slightly. Allow approximately 1/4-inch of fuel to collect in the generating pan under the burner coil and then close the fuel valve.
- g. Spread the wick in the pan under the burner coil and raise a small portion of the wick above the fuel.

### ⚠ WARNING

To prevent possible burns, always use a torch to light burners. Never attempt to light burners with a match or pocket lighter.

A fully charged dry chemical type fire extinguisher must be within easy reach whenever the burners are operating or there is an open flame near the distributor. Minimum dry chemical capacity of the fire extinguisher should be 10 pounds.

### ⚠ WARNING

To prevent explosion or fire hazard, never operate the burners inside the flues. Operating the burner inside the flue may cause over-generation (indicated by a short blue flame) resulting in the flame being extinguished. Fuel vapor will continue flowing into the flue until the fuel valve is closed.

**NOTE:** *If it is very windy during the generating phase, and the flame is blowing badly, it is acceptable to slide the burner partially or fully into the flue until the fuel in the generating pan is burned out. Pull the burner out of the flue for continued operation.*

- i. If there is more than six inches of material covering the upper flue, the second burner maybe used for heating.

A short blue flame that is easily extinguished indicates over-generation in the coils. This may be caused by an under-sized opening in the fuel valve, or by carbon build-up in the coils. Carbon build-up can be cleared from the vaporizing plug while the burner is in operation by using burner cleaning fluid furnished with your unit. A No. 51 drill bit may be used to bore out the vaporizing plug for a kerosene fuel burner. (Use a No. 54 drill bit for a diesel fuel burner.)

A yellow, smokey flame indicates the needle valve is open too far and too much fuel is reaching the burner (causing under generation). It can also be the result of too large a hole in the vaporizing plug. This condition presents a fire hazard and should be corrected immediately.

To shut down burners(s), close the burner fuel valve(s).

When the heating function is complete, push the burners inside the flues and replace the locking pins. Close the exhaust stack covers to prevent heat loss and to prevent water from entering stacks.

# CIRCULATING PRODUCT IN TANK

## **⚠ WARNING**

To prevent an explosion or fire hazard: Keep burning cigarettes or other sources of combustion away from manholes and overflow vents.

To prevent possible burns from leaking material, be sure all pipe, cap and hose connections are secure before opening valves.

To prevent possible burns from hot asphalt spray, do not stand, or allow anyone to stand, where accidental opening of a valve may cause contact with hot asphalt.

To prevent becoming entangled in machinery, stand clear of rotating drives.

## SET-UP

To determine if the product is hot enough to be circulated, proceed as follows:

Set the control valves and levers as shown in Figure 18.

**NOTE:** *If the unit is equipped with an optional inside closing valve, turn the hand wheel on the top-rear of the tank fully counterclockwise before proceeding.*

## Engine Drive Units

1. Shift the two speed transmission into low gear.
2. Engage the engine clutch and increase the engine speed so the pump tachometer reads 100 to 140 GPM.

To "Circulate and Fill" Position  
(Quadrant Control Lever)

Up  
(Vacu-Flo Valve Lever)

Pull Out  
(Butterfly Valve Lever)

Down  
(Intake Valve Lever)

Forward  
(Drain Valve Lever)

To "Distribute"  
(Transfer Valve Lever)

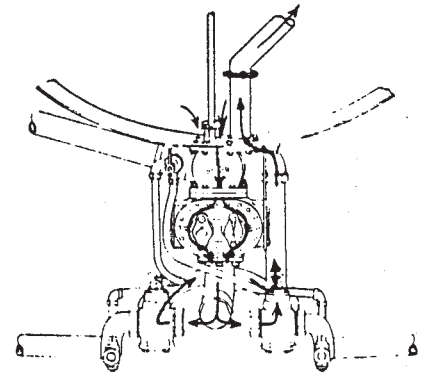
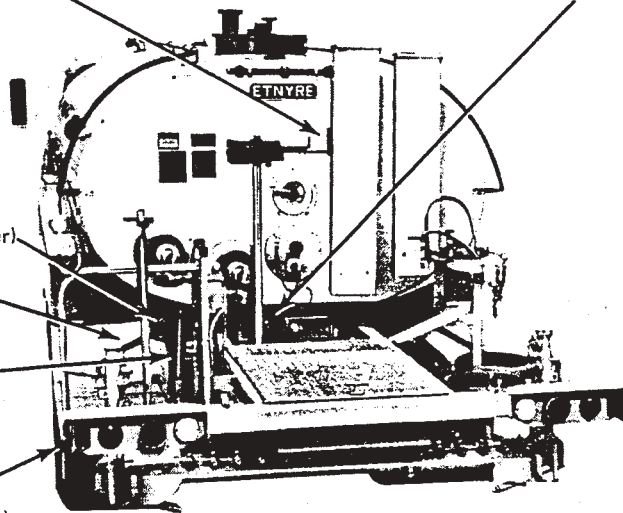


Figure 18. Valve Settings – Circulate Product in Tank

# CIRCULATING PRODUCT IN TANK

## Hydrostatic Drive Units

1. Set the truck engine RPM to about one third throttle.
2. Adjust the hydraulic control knob to obtain between 100 and 140 GPM on the pump tachometer.

Grasp the Intake Valve lever and slowly pull the lever downward. If the pump slows down and almost stops, quickly move the Intake Valve lever to the up position.

If the pump fails to quickly regain its speed, put a small amount of diesel fuel into the fill line to free up the pump.

Even if the product in the tank is at (or near) spraying temperature, the cold pump may chill the product sufficiently to lock up the pump. If this occurs, heat may be applied to the pump with a hand-held torch.

### WARNING

To prevent possible burns, use extreme caution when using a torch to heat the pump housing. Asphalt accumulated on and around the pump housing may ignite when heating the pump housing with a torch.

### WARNING

A fully charged dry chemical type fire extinguisher must be within easy reach whenever the burners are operating or there is an open flame near the distributor. Minimum dry chemical capacity of the fire extinguisher should be 10 pounds.

**NOTE:** To gain access to the pump, there is an opening in the sheet metal pump housing located several inches to the lower-right of the discharge head cap.

After approximately ten minutes of heating, try pulling the Intake Valve lever down again. Repeat manual heating of the pump if circulation cannot be accomplished.

If the product is too cold to be circulated, some heating with the flue burners will be needed to increase the temperature enough to start circulating. Refer to operating instructions for your particular burner type.

### WARNING

Allowing the flue burners to operate for a long period of time without circulating can damage the product and create explosive fumes. If product cannot be circulated after fifteen minutes of heating without circulation, the burners should be stopped for 20-30 minutes before re-lighting the burners.

Moving the distributor back and forth while the burners are off will allow the hot product to mix with the cooler product. This should decrease the time required to bring the product temperature up enough to start circulating. Once circulation has been established, the heating can continue without interruption. Circulate at 100-160 GPM.

### WARNING

To prevent an explosion or fire hazard, never move the vehicle when the burners are operating.

# CIRCULATING PRODUCT IN BAR

## ⚠ WARNING

To prevent an explosion or fire hazard: Do not remove material from tank in any manner when burners are in operation.

To prevent an explosion or fire hazard: Keep burning cigarettes or other sources of combustion away from manholes and overflow vents.

To prevent an explosion or fire hazard: Keep area free of sparks or open flames when spraying with volatile materials.

To prevent possible burns from leaking material, be sure all pipe, cap and hose connections are secure before opening valves.

To prevent possible burns from hot asphalt spray, do not stand, or allow anyone to stand, where accidental opening of a valve may cause contact with hot asphalt.

To prevent burns from accidental spraying, TUC bar must be OFF and remain OFF when spray bar is rotated upward.

To prevent burns, always wear insulated gloves when handling spray bar sections or hoses.

To prevent becoming entangled in machinery, stand clear of rotating drives.

## ⚠ WARNING

To prevent being struck by control lever on rear quadrant, stand clear when ON/OFF function is being performed with air control.

## SET-UP

Set the control valves and levers as shown in Figure 19.

## CIRCULATING PRODUCT IN BAR

## ⚠ CAUTION

To prevent excessive pressure in spray bar, asphalt pump speed should not exceed 160 GPM while circulating.

Circulate product long enough to ensure removal of all air from bar, and to heat spray valves sufficiently.

**NOTE:** Material will circulate in bar ends with extensions folded or in spraying position.

On engine drive units, partially close throttle if asphalt pump speed exceeds 160 GPM. Do not change governor setting.

On units with hydrostatic drive, pull hydraulic control knob up to decrease asphalt pump speed if pump speed exceeds 160 GPM. Do not change control knob setting.

To "Circulate in Bar" Position  
(Quadrant Control Lever)

Up  
(Vacu-Flo Valve Lever)

Pull Out  
(Butterfly Valve Lever)

Down  
(Intake Valve Lever)

Forward  
(Drain Valve Lever)

To "Distribute"  
(Transfer Valve Lever)

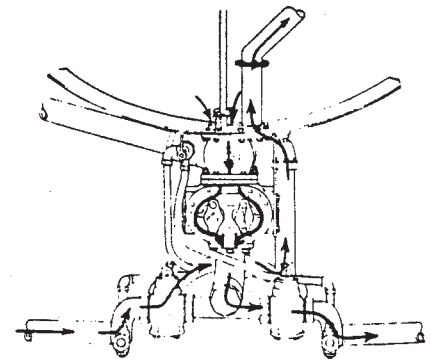
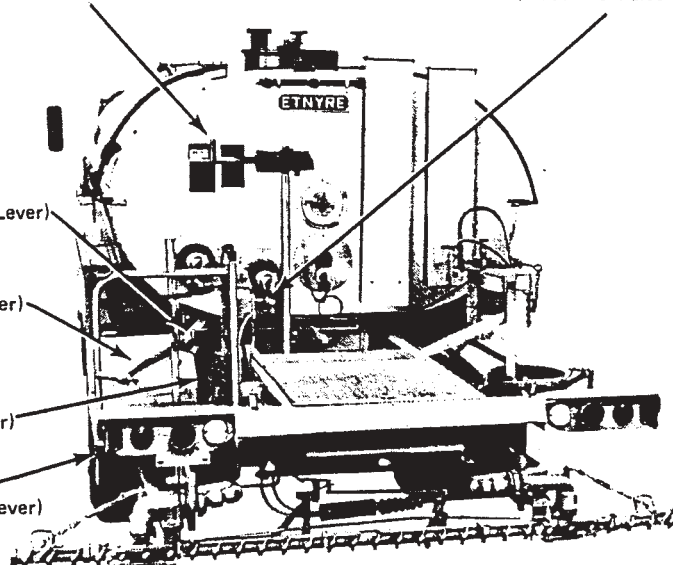


Figure 19. Valve Settings - Circulate Product in Bar

# SPRAYING OPERATIONS

## **⚠ WARNING**

To prevent an explosion or fire hazard: Do not heat material beyond the manufacturer's recommended temperature.

To prevent an explosion or fire hazard: Keep burning cigarettes or other sources of combustion away from manholes and overflow vents.

To prevent an explosion or fire hazard: Keep area free of sparks or open flames when spraying with volatile materials.

A fully charged dry chemical type fire extinguisher must be within easy reach whenever the burners are operating or there is an open flame near the distributor. Minimum dry chemical capacity of the fire extinguisher should be 10 pounds.

To prevent foaming or violent eruption, do not load tank with material temperature over 200° F if water or condensation is present in tank, or if emulsion was used in the previous load. Clean and thoroughly drain tank first. If water or emulsion may be present in spray bar or circulating system, allow a small amount of hot material to circulate in bar BEFORE filling tank. Do not heat material over 200° if moisture or emulsion is present in tank.

To prevent possible burns from leaking material, be sure all pipe, cap and hose connections are secure before opening valves.

To prevent possible burns from hot asphalt spray, do not stand, or allow anyone to stand, where accidental opening of a valve may cause contact with hot asphalt.

To prevent burns from accidental spraying, TUC bar must be OFF and remain OFF when spray bar is rotated upward.

To prevent possible burns from hot asphalt spray when hand spraying, hold hand spray gun in proper position and watch for other people.

## **⚠ WARNING**

To prevent burns, always wear insulated gloves when handling spray bar sections or hoses.

To prevent becoming entangled in machinery, stand clear of rotating drives.

To prevent being struck by control lever on rear quadrant, stand clear when ON/OFF function is being performed with air control.

## GENERAL

Correct spray cannot be obtained unless bitumen is heated to proper spraying temperature. Cold bitumen will not provide sharp spray edges, and will cause streaking. Refer to "Heating Bitumen in Distributors" for your particular burner type.

Refer to "Circulating Product for Spraying Operations" on Page 41 for setting proper asphalt pump speeds. Higher pump speeds will cause excessive fogging of spray. If higher pump and truck speeds are desired, use larger spray nozzles. Low pump speeds will cause spray fan to sag and cause heavy edges.

### Adjusting Spray Bar Nozzle Angle

Adjust nozzles to obtain an angle of approximately 30° with bar centerline (see Figure 20.). Every nozzle should be at the same angle.

**NOTE:** A nozzle adjustment wrench is supplied in the tool box of each new unit.

### Adjusting Spray Bar Height

Lower spray bar and adjust so that nozzles are approximately 12 inches above road when tank is empty. At this height spray fans will overlap to provide triple lap coverage. See Figure 20.

**NOTE:** Under heavy wind conditions it may be necessary to lower spray bar further.

### Valve Settings

1. Set operating valves and levers as shown in Figure 21.

# SPRAYING OPERATIONS

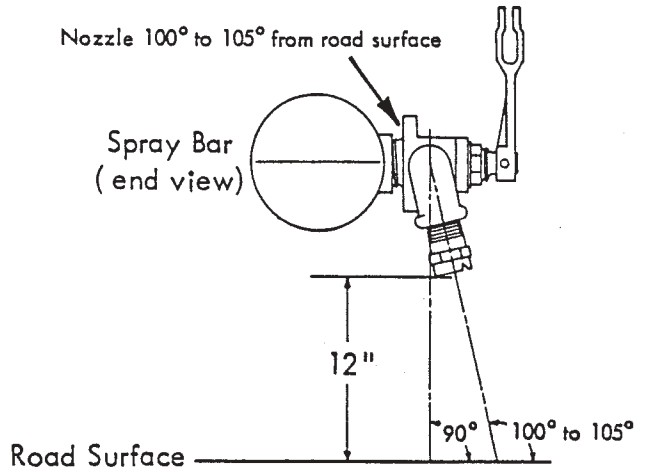
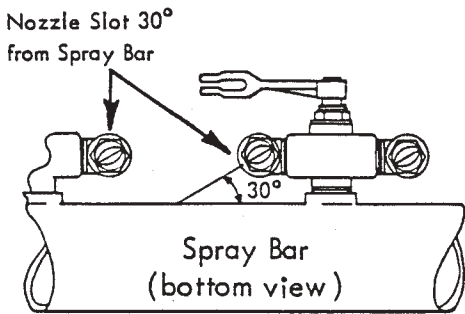


Figure 20. Adjusting Spray Bar Nozzles

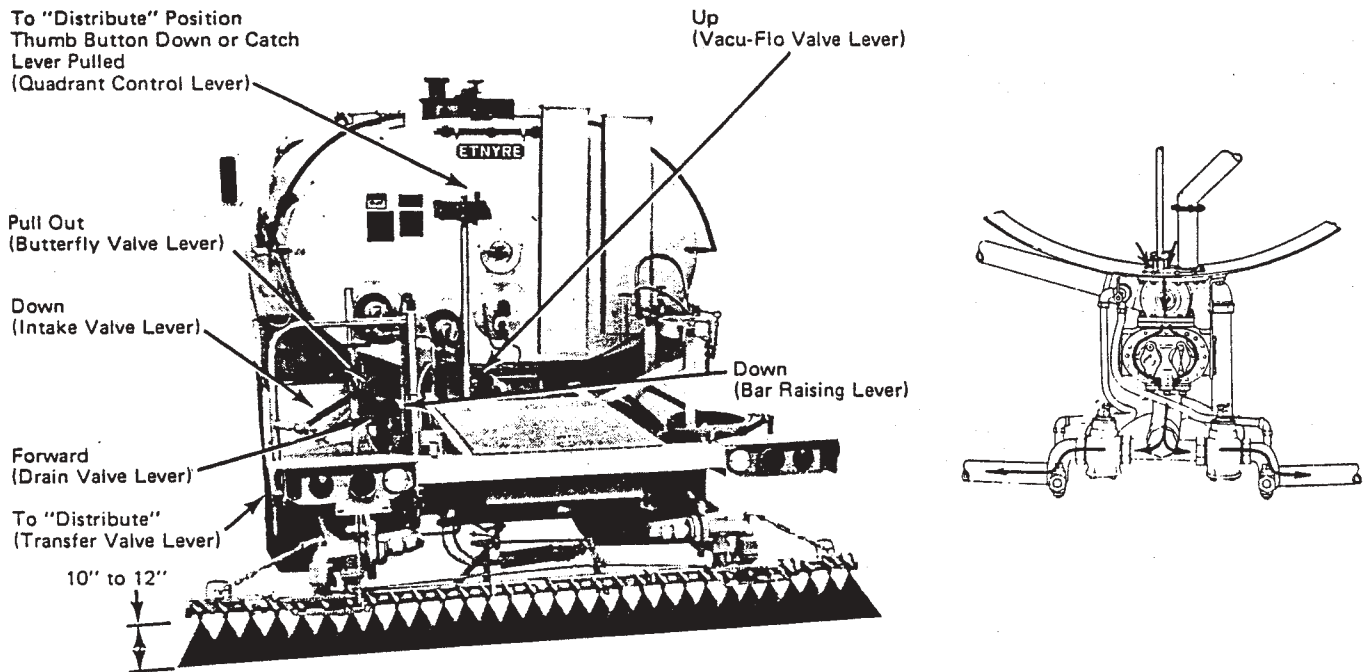


Figure 21. Valve Settings for Spraying Operations

# SPRAYING OPERATIONS

## SPRAYING WITH ENGINE DRIVE MODELS

1. If throttle was partially closed to limit pump speed while circulating product in bar, re-open throttle to proper setting before spraying and immediately put truck in motion.

### CAUTION

*To prevent damage to equipment, on units with "FC" spray bars do not move control lever to spraying position if end section is folded without first removing shoulder bolt at hinge that controls extension valves.*

2. To spray, push thumb button down or pull catch lever up (depending on control style), and move Quadrant Control Lever from "Circulate In Bar" to "Distribute" position. On units with one man control, lock thumb button down with "T" shaped lever provided.

**NOTE:** *Thumb button or catch lever is used only to engage control for turning spray bar valves on and off.*

3. To stop spraying, return Quadrant Control Lever to "Circulate In Bar" position. Release thumb button or catch lever if spraying operation is completed.
4. Reduce throttle setting if asphalt pump speed exceeds 160 GPM. This will prevent excess pressure in spray bar.

## SPRAYING WITH HYDROSTATIC MODELS

1. Engage truck transmission in gears previously determined for proper application speeds. See "Establishing Hydrostatic Drive Settings" in Preparing New or Rebuilt Units.
2. If hydraulic control knob was pulled up to limit pump speed while circulating product in bar, push control down against stop before spraying and immediately put truck in motion.

### CAUTION

*To prevent damage to equipment, on units with "FC" spray bars do not move control lever to spraying position if end section is folded without first removing shoulder bolt at hinge that controls extension valves.*

3. To spray, push thumb button down or pull catch lever up (depending on control style), and move Quadrant Control Lever from "Circulate in Bar" to "Distribute" position. On units with one man control, lock thumb button down with "T" shaped lever provided.

**NOTE:** *Thumb button or catch lever is used only to engage control for turning spray bar valves on and off.*

4. Before spraying, momentarily drive at dry run speed to check that bitumeter and pump tachometer reading are still at predetermined ratio. The desired application rate will be applied regardless of road speed.
5. To stop spraying, return Quadrant Control Lever to "Circulate in Bar" position. Release thumb button or catch lever if spraying operation is completed.
6. Reduce throttle setting if asphalt pump speed exceeds 160 GPM. This will prevent excess pressure in spray bar.

## CIRCULATING PRODUCT FOR SPRAYING OPERATIONS

To set engine governor or hydrostatic controls for spraying requirements when circulating in tank, set pump speed as follows:

1/8" Nozzles: 10–15 GPM per foot of bar length

*Example:* 160–240 GPM for a 16-foot spray bar length

1/16" Nozzles: 15–20 GPM per foot of bar length

*Example:* 240–320 GPM for a 16-foot spray bar length

3/32" Nozzles: 7–10 GPM per foot of bar length

*Example:* 112–160 GPM for a 16-foot spray bar length

# SPRAYING OPERATIONS

## SHOULDER SPRAYING

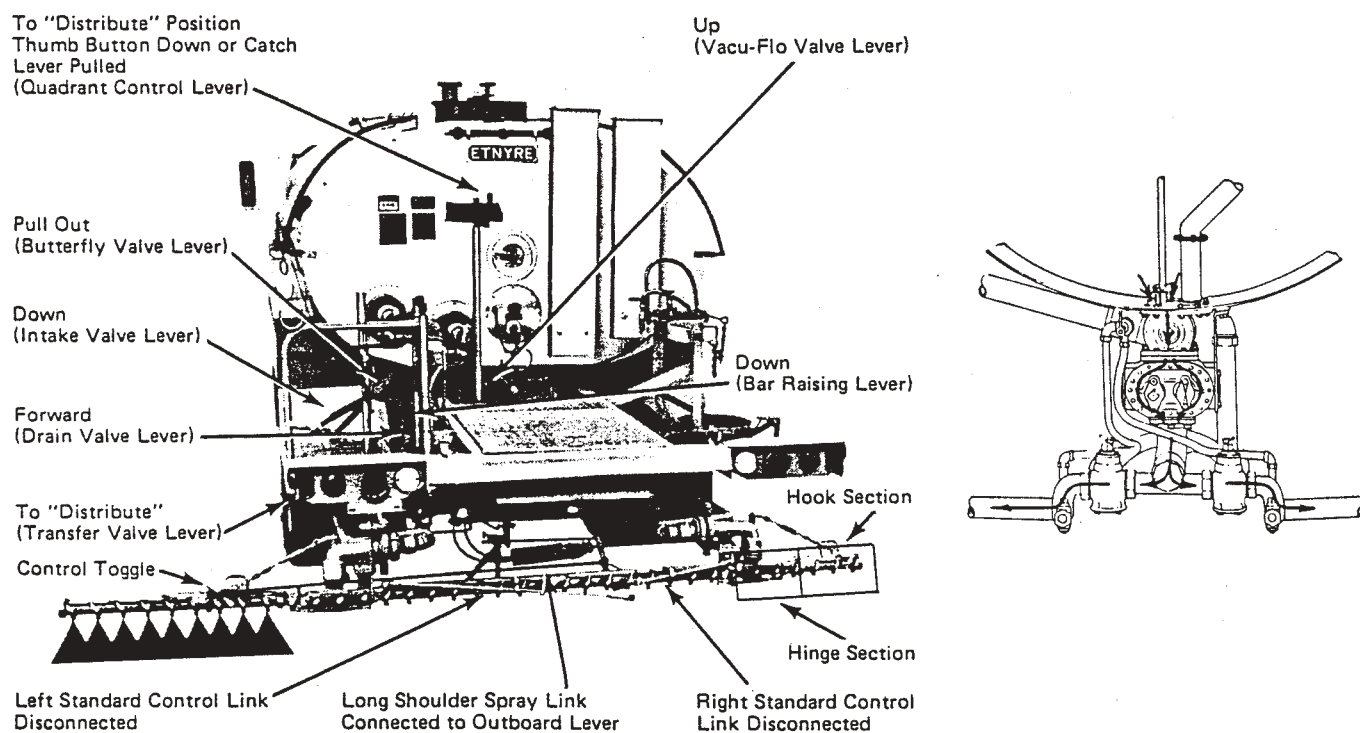


Figure 22. Shoulder Spraying With "TUC" Spray Bar (Left Side Shown)

### "TUC" Spray Bar

1. Set the operating valves and levers as shown in Figure 22.
2. Two special shoulder spraying control links are provided. The longer link is used to spray shoulders on the left, the shorter link for shoulders on the right. To use the shoulder spraying links, disconnect the standard control links from the center fulcrum and place them in hanger on center control bars.
3. Place appropriate shoulder link on center fulcrum.
4. Remove "pull pin" on connecting link between center half and outer bar section on side that is to spray.
5. Follow normal spraying procedures.

**NOTE:** On TUC bars equipped with flip valves on hinge section and/or hook sections it is necessary to disengage flip levers out to the control toggle on hook section before installing the shoulder spray linkage.

**NOTE:** To spray 6-foot center section only, remove pull pins from connecting links between center and outer bar sections.

### "FC" Spray Bar

1. See Figure 23. and set the operating valves and levers for spraying with "TUC" spraybar.
2. For side not to spray, disconnect control linkage by removing corresponding pin in center fulcrum.
3. On side to spray, remove shoulder bolt connecting control linkage that connects to center section bus bar. This disconnects half of center section that would otherwise spray.
4. Follow normal spraying procedures.

**NOTE:** To spray 6-foot center section only, remove both shoulder bolts controlling valves in end sections.



# SPRAYING OPERATIONS

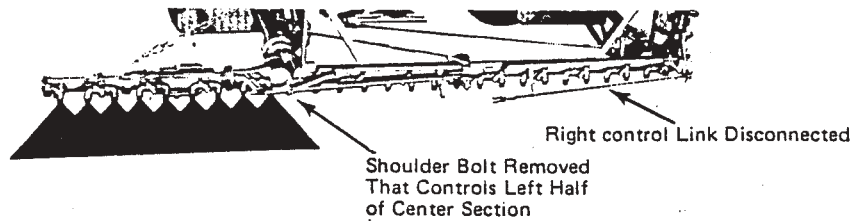


Figure 23. Shoulder Spraying With "FC" Spray Bar (Left Side Shown)

## DRAWING MATERIAL IN BAR BACK INTO TANK

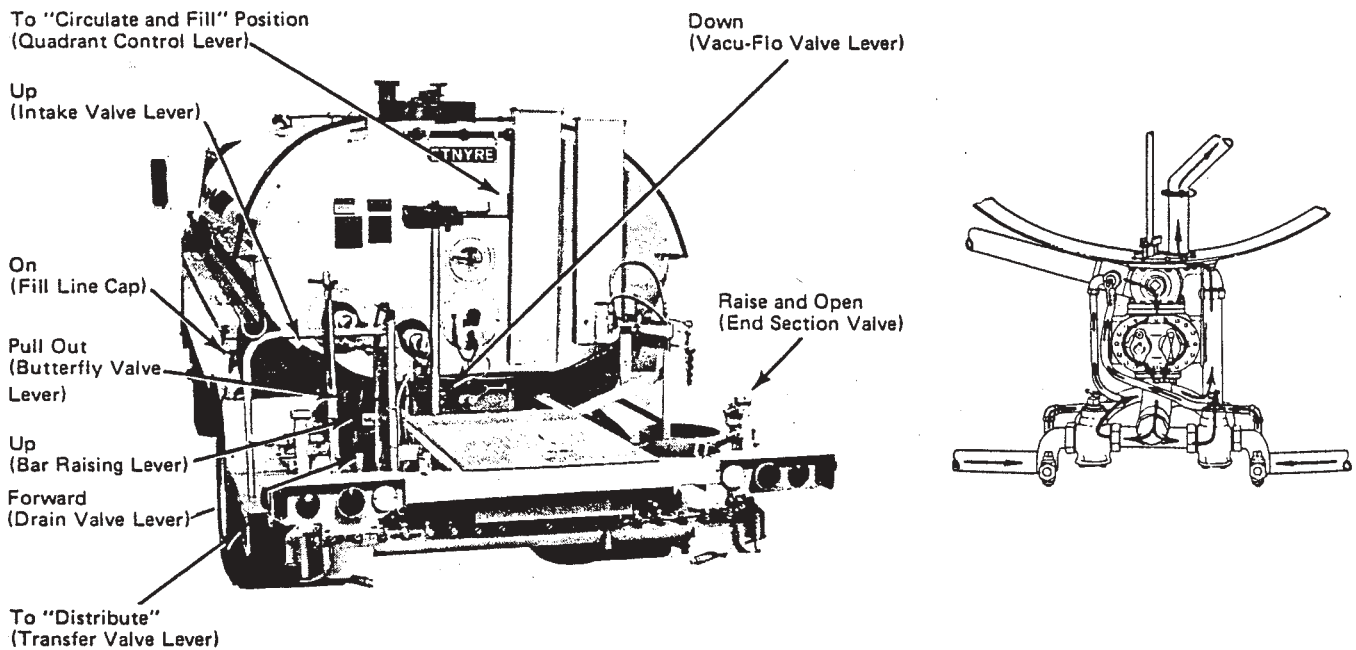


Figure 24. Drawing Material in Bar Back Into Tank

1. Set the operating valves and levers as shown in Figure 24.
2. With "TUC" spray bar, turn bar up by raising bar turn-up lever. Raise spray bar end sections (all bar models).
3. Run pump at 10 GPM per foot of bar.
4. After drawing material back for approximately 2 minutes, open end valves allowing air to enter system. For maximum cleaning, turn Vacu-Flo valve to left and right when sound of pump indicates bar is empty.
5. When draw-back is complete, turn Vacu-Flo lever up to close.

# SPRAYING OPERATIONS

## HAND SPRAYING

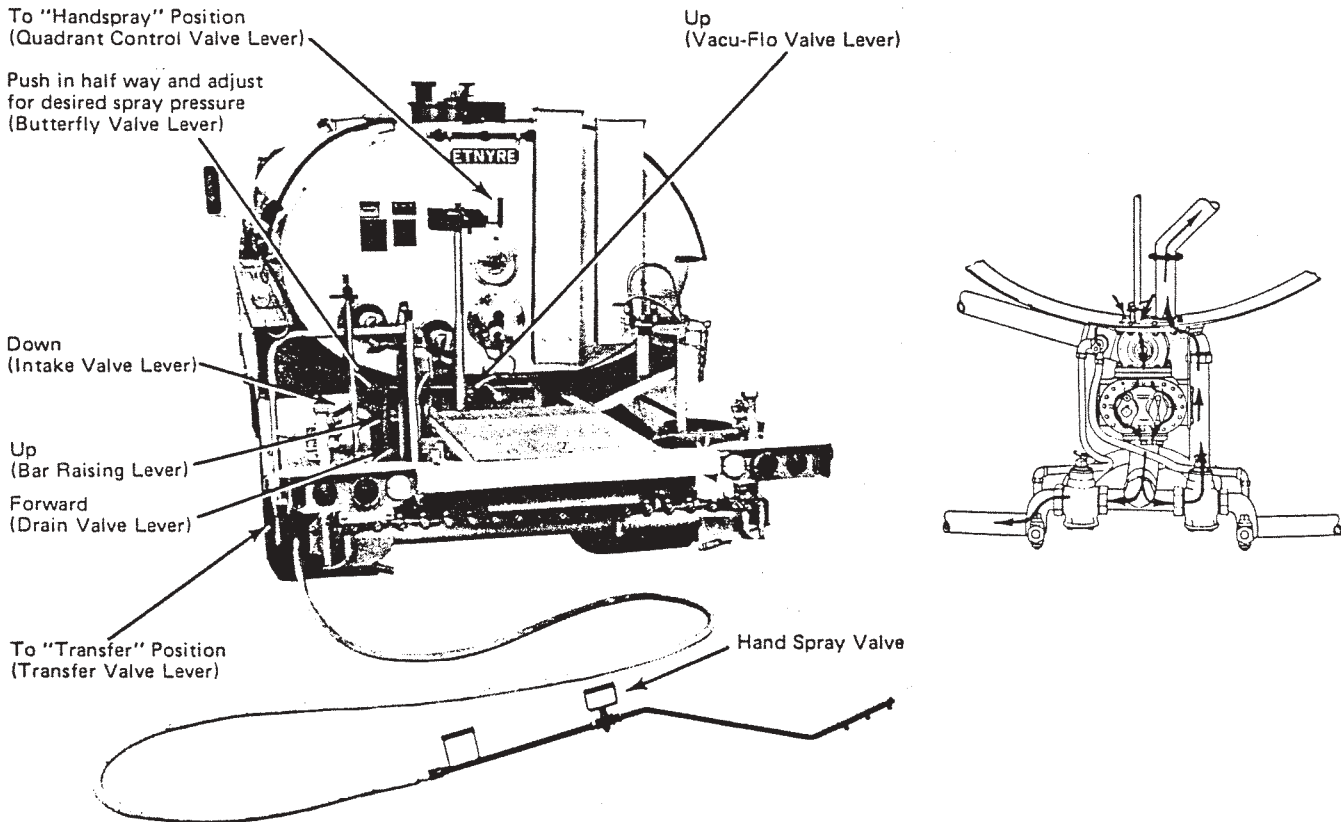


Figure 25. Valve Settings For Hand Spraying and Pump-Off

### **WARNING**

To prevent possible burns from hot asphalt spray when hand spraying: Hold hand spray gun in proper position and watch for other people.

To prevent burns: Always wear insulated gloves when handling spray bar sections or hoses.

1. Set the operating valves and levers as shown in Figure 25.
2. Turn hand spray valve 90° on hand spray gun for spraying.
3. Adjust hand spray pressure with butterfly valve. Push in lever to increase, pull out to decrease.
4. When finished hand spraying, proceed as follows:
  - a. Pull Butterfly Valve lever out.
  - b. Close Intake Valve by moving lever up.
  - c. Move Quadrant Control Lever to "Circulate And Fill" position.

- d. Suck back material from hand spray hose by turning Vacu-Flo lever to the left position. After approximately 1 minute crack hand spray valve open on hand spray hose.

**NOTE:** If finished hand-spraying for the day, crack hand spray valve open with nozzle submerged in flushing oil.

- e. Turn Transfer Valve lever back to "Distribute" position.
  - f. Disconnect hand spray hose.
  - g. Turn Vacu-Flo lever straight up to normal position.
5. If desired to blow out hand spray hose after spraying, proceed as follows:
    - a. Raise intake valve lever
    - b. Remove filling cap
    - c. Open hand spray valve and push butterfly valve in against stop. Add flushing oil if desired.

# SPRAYING OPERATIONS

## PUMP OFF

1. Set the operating valves and levers as shown in Figure 25.

**NOTE:** When pumping off, ensure that all valves in pump off line between distributor and storage tank are open before moving intake valve lever down.

2. When finished pumping off proceed as follows:
  - a. Pull Butterfly Valve lever out.
  - b. Close valve at storage tank soon after pulling Butterfly Valve Lever out.
  - c. Close Intake Valve by moving lever up.
  - d. Move Quadrant Control Lever to "Circulate and Fill" position.
  - e. Suck back material from pump-off line by turning Vacu-Flo lever to the left position. After approximately 1 minute open pump-off line.
  - f. Turn Transfer Valve lever back to Distribute position.

- g. Disconnect pump-off line.
- h. Turn Vacu-Flo lever straight up to normal position.

## AFTER SPRAYING

1. Drain and flush out pump, bar and circulating system after each use (unless oil is light enough that it will not "set up" when cold).
2. Clean pump outlet strainer weekly.

## TRANSFERRING MATERIAL FROM SUPPLY SOURCE TO STORAGE

1. Connect hose from supply source to the filling connection. Be sure connections are tight.
2. Connect hose from storage to transfer connection. Be sure connections are tight.
3. Set the operating valves and levers as shown in Figure 26.

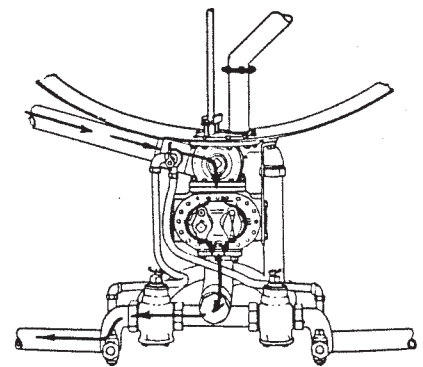
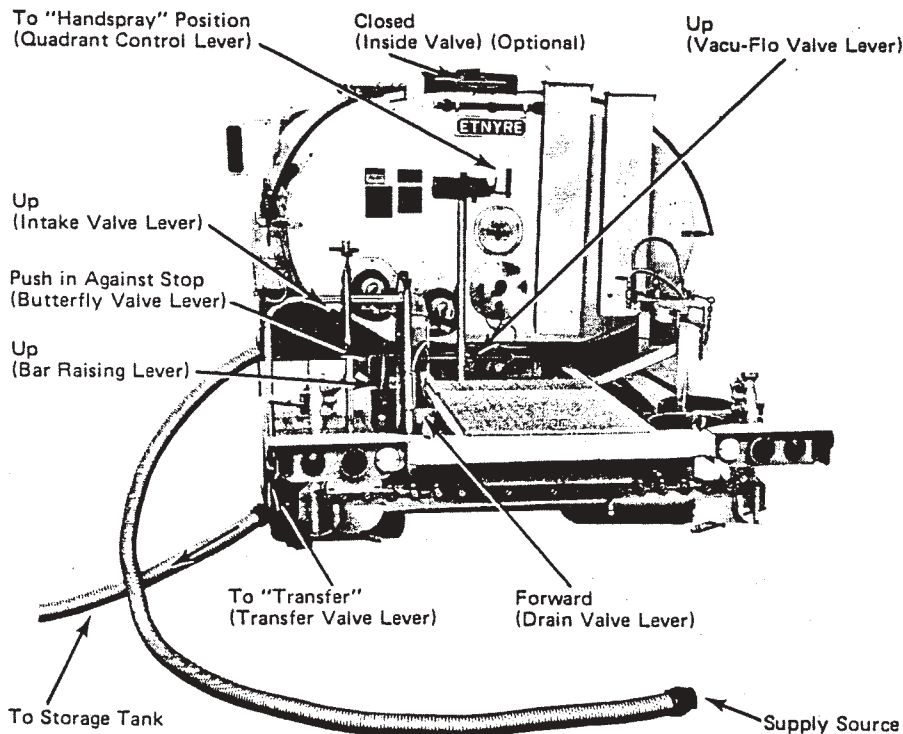


Figure 26. Transferring Material From Supply Source to Storage

# SPRAYING OPERATIONS

## DRAINING CIRCULATING SYSTEM AND SPRAY BAR

1. Raise spray bar and fold up end sections.

**NOTE:** On units with "TUC" bar, turn up bar before folding end sections.

2. Set the operating valves and levers as shown in Figure 27.

**NOTE:** If unit is equipped with optional inside closing valve, open by turning counter-clockwise.

**NOTE:** If using optional right hand transfer valve, move Quadrant Control Lever to "Circulate in Bar" position.

3. Run pump at maximum speed where it will run quietly. Normally, 150 GPM is best transfer speed.

4. When through transferring, turn Transfer Valve lever to Distribute position. Pull Butterfly Valve lever back out against stop.

**NOTE:** If oil enters distributor tank when transferring, Butterfly Valve is not closed tight.

5. Run the pump on low idle to drain the system.

6. When draining operation is complete, push Drain Valve lever forward and turn Quadrant Control Lever to "Circulate in Tank" position.

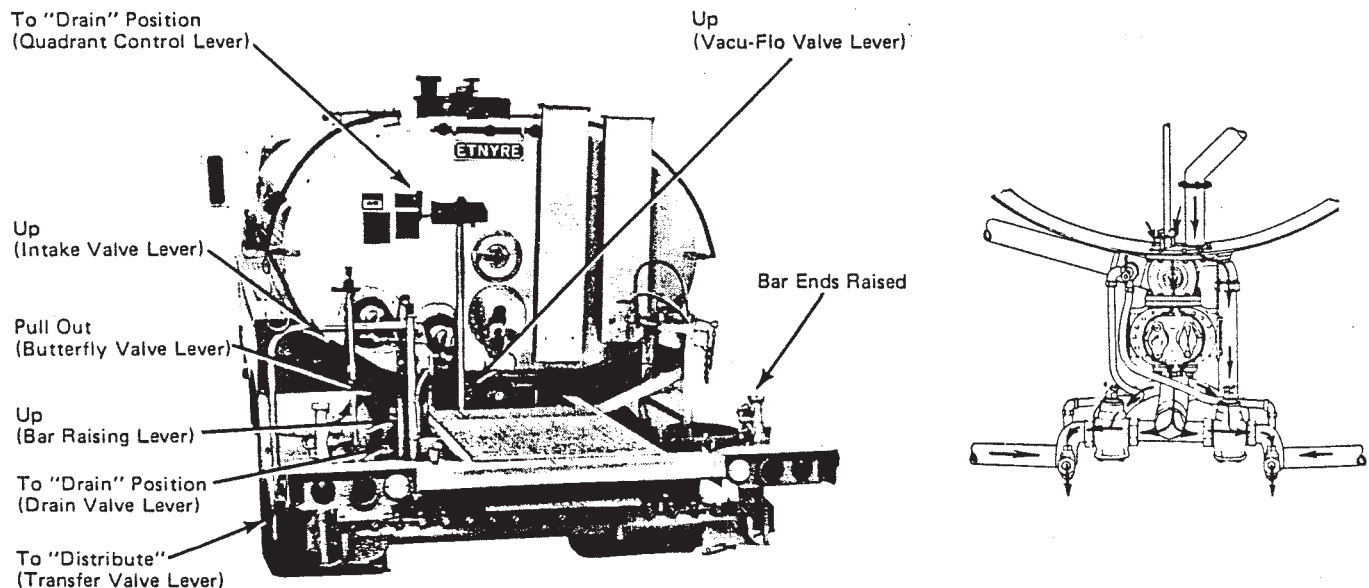


Figure 27. Draining Circulating System and Spray Bar

# SPRAYING OPERATIONS

## FLUSHING BAR, CIRCULATING SYSTEM AND TANK

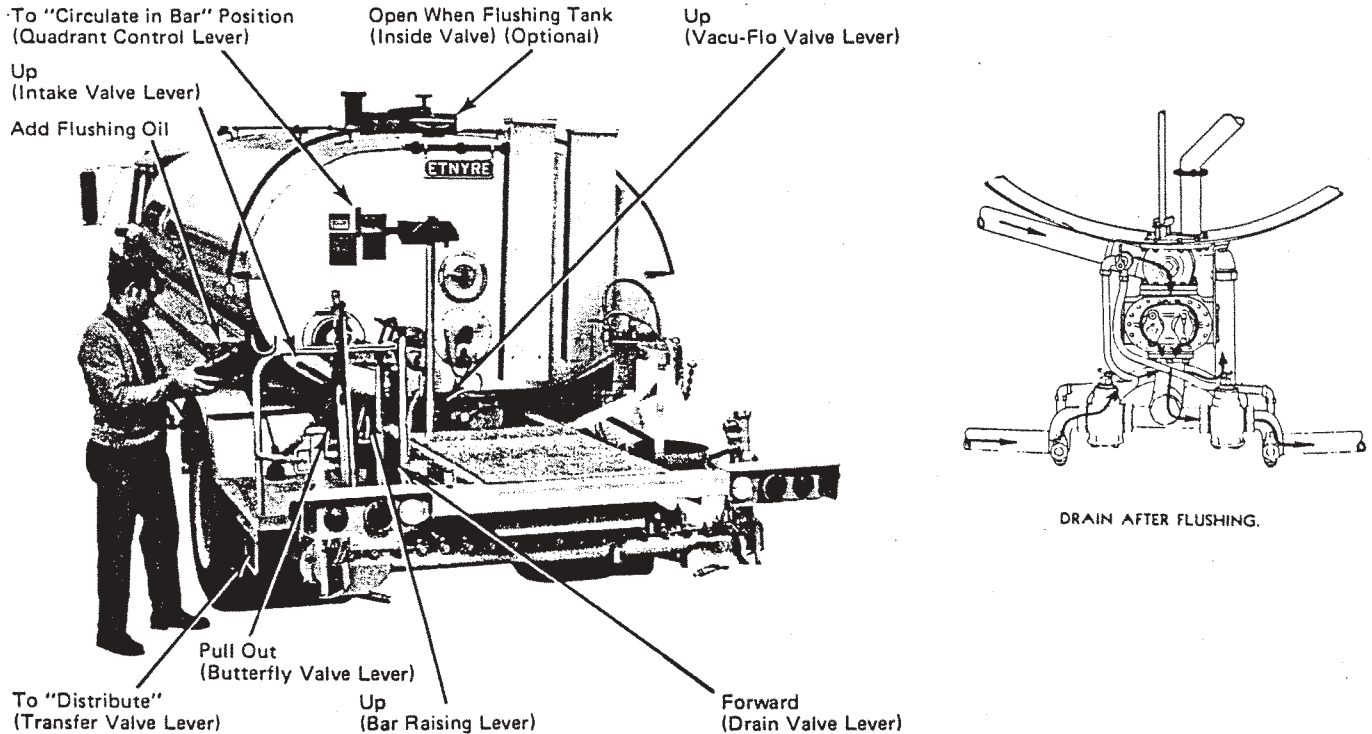


Figure 28. Flushing Spray Bar, Circulating System and Tank

1. Set the operating valves and levers as shown in Figure 28.
2. After draining circulating system and spray bar, put Quadrant Control Lever in "Circulate in Bar" position.
3. Move Intake Valve lever to UP position.
4. Run pump at low idle.
5. Put 3 quarts of flushing oil in filling line, using can provided.

**NOTE:** If tank is to be flushed, leave Intake Valve lever in closed position until 5 gallons or more of flushing oil have been added, then push lever down, opening Intake Valve.

**NOTE:** After flushing operations, drain residual material before subsequent recirculation.

### WASHOUT TO PREVENT CONTAMINATION OF THE BINDER MATERIAL

Draw material from spray bar back into tank as described on Page 46. In order to obtain the maximum vacuum for better cleaning, increase the pump speed to 250-300 GPM.

Normally the suck back procedure will remove sufficient material from the circulating system to negate the need for draining the circulating system and spray bar as described on Page 46 before proceeding with the washout operation.

**NOTE:** If difficulty is encountered trying to circulate material through the system on the next start-up, it is advisable to follow the drain procedure prior to flushing the pump and or spray bar. Allow the Intake Valve to remain in the Fill position unless complete draining of the tank is desired.

The flushing operation utilizes only 3 quarts of flushing solvent. This small amount is not sufficient to fill the lines to the tank thus preventing solvent from being forced into the tank.

A common practice following completion of the flushing procedure and subsequent shut-down is to pour 1-2 quarts of solvent into the fill line which softens or dissolves the residual asphalt in the pump. Allow solvent to remain in system overnight.

Before start-up, repeat drain procedure.

# TROUBLESHOOTING

Trouble	Cause	Remedy
Spray Fogs	Pump speed too fast for size of nozzle.	Lower pump speed or change nozzles. See "Establishing Flow Rate/Ground Speed Ratio."
Spray Streaks	Pump speed too slow.  Nozzles not at proper angle.  Spray bar at improper height above ground.  Material temperature too low.	Increase pump speed. See "Establishing Flow Rate/Ground Speed Ratio."  Adjust angle of nozzles.  Adjust spray bar height.  Heat material to correct temperature.
Spray Lacks Pressure.	Pump speed too slow.  One or more control valves in incorrect position, not fully opened or closed, or leaking.  Discharge strainer plugged.	Adjust pump speed.  Check position of all control valves. Be sure all valves are fully opened or closed. Repair leaking valves as necessary.  Clean discharge strainer.
All Nozzles Do Not Cut Off Spray.	Spray bar linkages not adjusted correctly.	Adjust linkage.
Left Control Valve Leaks At Top.	Pump speed too high when circulating in bar.	Adjust pump speed.
Intake Valve Leaks.	Loose spring on operating shaft, or damaged valve.	Tighten spring on operating shaft or repair valve.
Pump Slows When Moving Quadrant Control Lever From Circulate In Tank To Circulate In Bar.	Butterfly Valve closed.	Open Butterfly Valve by pulling on control link.
Quadrant Control Lever Turns Hard When Moving From "Circulate In Bar" To "Spray" Position.	Spray bar valves not adjusted properly.	Adjust spray bar valves.
Pump Will Not Turn, Or Turns Slowly.	Material in tank or pump below pumping temperature.  Air leak in suction line from reservoir to filter to inlet of charge pump.  Hydraulic system pressure low.  Low oil in hydraulic reservoir.  Spray bar valves set improperly.  Defective pump or motor.	Heat material to proper pump temperature.  Locate and repair leak.  Raise pressure.  Add hydraulic oil to correct level.  Correct spray bar valve settings.  Check for excessive case drain in pump and/or motor. Repair or replace defective components.

# TROUBLESHOOTING

Trouble	Cause	Remedy
Hydraulic Oil Overheats.	<p>Material in tank or pump below pumping temperature.</p> <p>Air leak in suction line from reservoir to filter to inlet of charge pump.</p> <p>Low oil in hydraulic reservoir.</p> <p>Spray bar valves set improperly.</p>	<p>Heat material to proper pump temperature.</p> <p>Locate and repair leak.</p> <p>Add hydraulic oil to correct level.</p> <p>Correct spray bar valve settings.</p>
Spray Bar Supply Tube Ball Joints Leak.	<p>Ball joint retaining ring is loose.</p> <p>Ball joint gaskets not fully seated.</p>	<p>Tighten or replace ball joint retaining ring.</p> <p>Circulate hot material through spray bar and supply tubes while shifting spray bar from side to side. This should seat gaskets and stop leaks.</p> <p><i>NOTE: When using emulsions below recommended pumping temperatures, it may be necessary to heat ball joints with a torch to help seat gaskets.</i></p> <p><i>CAUTION: To prevent damage to equipment, do not allow flame to be applied directly to gasket material.</i></p>
Application Rate Varies.	<p>Quantity of material in tank not being measured accurately.</p> <p>Discharge strainer plugged.</p> <p>Engine governor or hydrostatic controls not firmly positioned.</p> <p>Thumb button on quadrant control lever not properly engaged.</p> <p>Faulty tachometer or bitumeter.</p>	<p>Use Etnyre measuring stick for accurate readings. Be sure tank is level when measuring.</p> <p>Clean discharge strainer regularly.</p> <p>Ensure that all controls are firmly locked in place.</p> <p>On air control units, thumb button should be held down with "T" shaped catch. On units with single control shafts, pull engagement lever outward.</p> <p>Have tachometer and/or bitumeter checked and calibrated.</p>

# SERVICING THE ETNYRE P-15 PUMP

## VACUUM CHECK

1. Flush pump with 3 quarts of diesel fuel through fill line.
2. Set controls for filling operation (see Page 20).
3. Install vacuum gauge in fill line cap.
4. Operate pump at 140 GPM on pump tachometer. A vacuum reading of less than 5 Hg. (inches of mercury) after 2 minutes of operation indicates a vacuum leak or a worn pump.

## PUMP DISASSEMBLY AND INSPECTION

1. Remove double universal joint between motor and asphalt pump.
2. Remove sheet metal housing for easy access to pump.

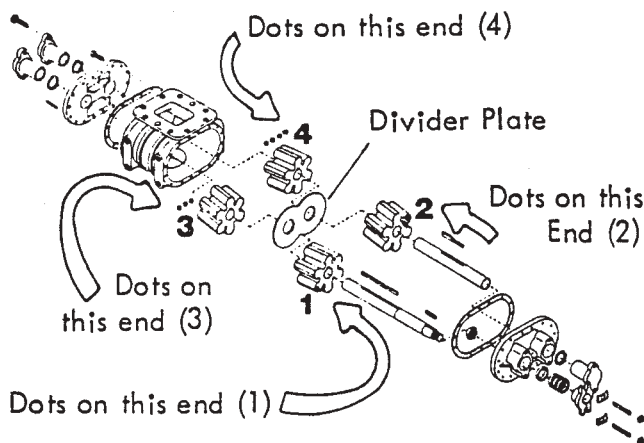


Figure 29. Etnyre P-15 Pump

3. Remove 20 capscrews from perimeter of pump end plate (see Figure 29).
4. Install two capscrews in the threaded holes near the outer edge of the end plate at approximately the 5 o'clock and 11 o'clock positions. Tighten the capscrews evenly to force the endplate away from the pump body.

5. Remove the endplate, impeller shafts and impellers (gears) as an assembly.
6. Clean the interior of the pump case. Slide your fingers across the interior surfaces of the case. If a narrow raised area can be felt midway between the front and rear of the case, the entire pump should be replaced.
7. If there is no raised area, measure the bore of the case at its widest point horizontally (side-to-side). This measurement must not exceed 9.910 inches.
8. Next, measure the case bore vertically at a point 2.8 inches from each side. The vertical measurement must not exceed 5.660 inches. If any bore measurements exceed these limits, the entire pump must be replaced.
9. If inspection indicates the pump case is acceptable, measure the outside diameter of the impeller gears. Measure the impeller gears from tooth point to tooth point on teeth directly opposite each other. The minimum outside diameter of the gears should be 5.635 inches. The minimum length of the gears should be 3.628 inches.
10. If any impeller gear is undersize, the entire four-gear set must be replaced.
11. End plate gasket thickness should be 0.014–0.016 inches.
12. Divider plate thickness should be 0.127–0.128 inches.

## IMPELLER INSTALLATION AND PUMP ASSEMBLY

Each impeller gear set uses a series of dots on the gear faces to indicate position of the gears within the pump. Refer to Figure 29. for proper positioning of the gears. The dots must face away from the divider plate (towards the ends of the pump). Install the impellers in numerical order.



# HYDROSTATIC PUMPS AND MOTORS

## DYNAPOWER

### HYDROSTATIC MOTOR PRESSURE CHECK AND ADJUSTMENT

#### CAUTION

*When working on hydraulic system, cleanliness of hands, parts, tools and immediate area is essential! Introduction of any foreign material into hydraulic system may cause damage to the equipment.*

#### Equipment Required

1. 5000 PSI Pressure Gauge.
2. Anchor adaptor No. 4BC-4UFS or 6BC-4UFS (or equivalent).
3. Anchor O-ring No. 383-4 or M-383-6 (or equivalent).
4. Minimum 2-foot length high pressure hose for gauge.
5. Etnyre shim kit No. 740064
6. Vaseline or petroleum jelly.

#### Initial Pressure Check

#### WARNING

**High pressure can cause injury or death. Use only equipment rated for the maximum pressure of the system. Ensure that fittings are tight. Do not touch or stand in close proximity to components under pressure.**

1. On bottom of hydraulic motor, remove right hand 9/16" plug and install the 5000 PSI gauge with the adaptor and O-ring.
2. Lock hydraulic motor by one of the two methods below, and take a pressure reading to determine the bypass pressure setting at the hydraulic motor.
3. Method #1 - With Material in Distributor Tank:
  - a. Set distributor controls for hand spray operation.
  - b. Leave Transfer Valve in "Distribute" position
  - c. Run pump at 100 GPM.

#### CAUTION

*To prevent damage to equipment, do not operate hydraulic system at bypass pressure for extended periods. Overheating of the oil will result, causing possible damage to the equipment. Overheating of oil also affects pressure readings.*

- d. Slowly close Butterfly Valve while observing pressure gauge. Close Butterfly Valve until hydraulic motor stops. Highest reading on gauge is bypass pressure.
4. Method #2 - With Distributor Tank Empty:
    - a. In cab, pull hydraulic control knob to its uppermost position. Adjust fine control tube until it is against bottom of hydraulic control knob.
    - b. At rear of distributor, lock universal coupling between pump and motor with a pipe wrench of sufficient length to lay against left distributor frame.
    - c. Set truck engine to fast idle (minimum 1000 RPM).
    - d. Engage PTO.

#### CAUTION

*To prevent damage to equipment, do not operate hydraulic system at bypass pressure for extended periods. Overheating of the oil will result, causing possible damage to the equipment. Overheating of oil also affects pressure readings.*

- e. Pull out Rear Override Control while observing pressure gauge. Highest reading on gauge is bypass pressure.

#### Pressure Evaluation

Bypass pressure at hydraulic motor (with motor locked) should be 5000 PSI. If pressure is normal (not low), consult the Troubleshooting section of this manual for more information. If pressure is low, check the following two items before changing the relief valve pressure.

1. Check for air leaks at the four connections in the line from the hydraulic reservoir to the filter to the hydraulic pump. Air drawn into the hydraulic oil will cause the oil to appear milky in color and result in low system pressure. Tighten fittings or replace components as required.

# HYDROSTATIC PUMPS AND MOTORS

## DYNAPOWER

2. Check the case drain rate in both the hydraulic pump and motor as described below. Maximum case drain rate is 1/2 gallon per 1000 PSI. For example, if the initial pressure reading was 3000 PSI, the maximum allowable case drain rate would be 1.5 GPM.

### Hydraulic Pump Case Drain Flow Rate Check

#### ⚠ CAUTION

When working on hydraulic system, cleanliness of hands, parts, tools and immediate area is essential! Introduction of any foreign material into hydraulic system may cause damage to the equipment.

1. Disconnect case return line from hydraulic pump as shown in Figure 30.

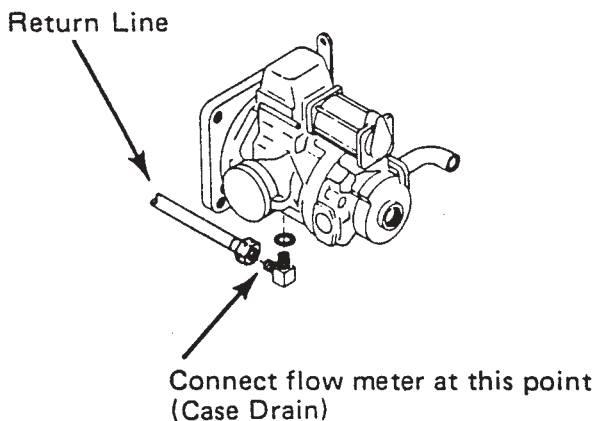


Figure 30. Checking Hydraulic Pump Case Drain Rate

2. Connect a flow meter as shown in Figure 30., or direct oil flow into a container of known volume for a measured amount of time to determine the flow rate in gallons per minute (GPM). If the flow rate is above the maximum allowed, the pump is worn internally and should be replaced or repaired before proceeding.

**NOTE:** If oil is directed into a clean, dry container, the oil may be saved and returned to the reservoir.

### Hydraulic Motor Case Drain Flow Rate Check

1. Disconnect low pressure line at motor tee (see Figure 31.). Disconnect return line from tee and remove tee from motor.

#### ⚠ CAUTION

With low pressure line disconnected from pump, be careful not to run pump dry causing damage to system.

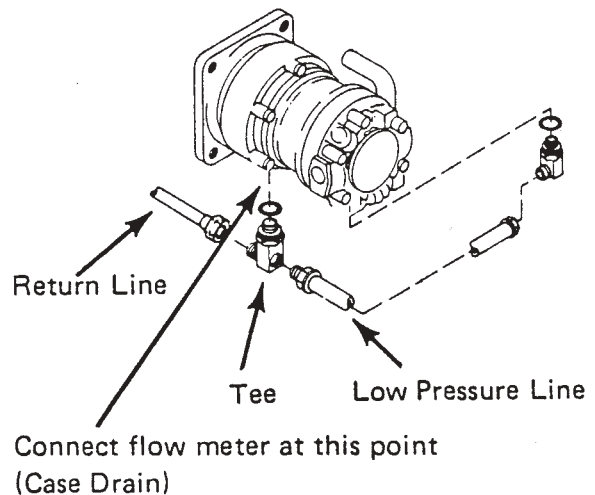


Figure 31. Checking Hydraulic Motor Case Drain Rate

2. Connect flow meter to motor as indicated in Figure 31., or direct flow from tee port into a container of known volume for a measured amount of time to determine the flow rate in gallons per minute (GPM). If the flow rate is above the maximum allowed, the pump is worn internally and should be replaced or repaired before proceeding.

**NOTE:** If oil is directed into a clean, dry container, the oil may be saved and returned to the reservoir.

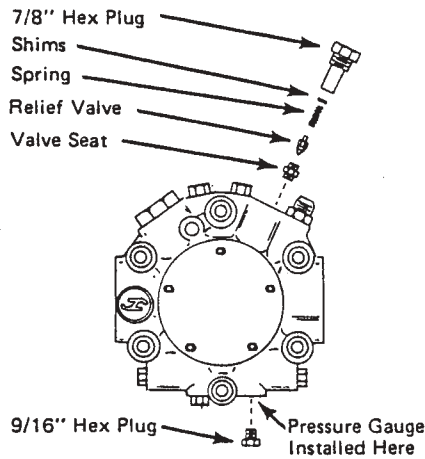
### Hydraulic Motor Relief Valve Adjustment

If no air leaks are found, and pump and motor case drain rates are acceptable, adjust relief valve setting as follows. First determine which type of motor has been installed on your distributor by comparing to the illustrations below; then adjust relief valve per the appropriate instructions.

# HYDROSTATIC PUMPS AND MOTORS

## DYNAPOWER

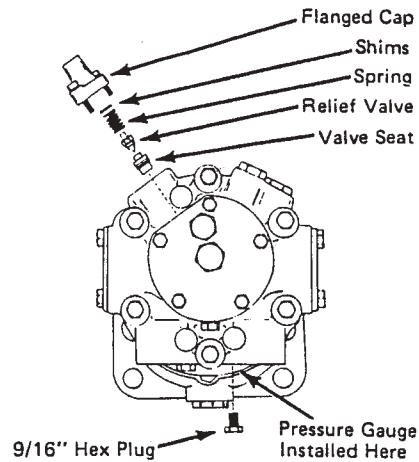
### Type I Hydraulic Motor



AS VIEWED  
FROM REAR OF DISTRIBUTOR

Figure 32. Type I Hydraulic Motor

### Type II Hydraulic Motor



AS VIEWED  
FROM REAR OF DISTRIBUTOR

Figure 33. Type II Hydraulic Motor

### ⚠ CAUTION

*When working on hydraulic system, cleanliness of hands, parts, tools and immediate area is essential! Introduction of any foreign material into hydraulic system may cause damage to the equipment.*

**NOTE:** *When removing plug, be careful not to drop parts into discharge port. If parts fall into port they may be retrieved with a pencil magnet.*

1. There are two 7/8" plugs located on top of the motor. Remove the plug nearest the universal coupling between the pump and the motor.
2. Add shims to increase relief valve setting. Pressure may be increased at a rate of 50 PSI per one-thousandth inch (.001") of shim. Recommended pressure is 4000–4500 PSI.
3. Before replacing plug, place a dab of vaseline or petroleum jelly on end of tube to prevent parts from dropping out.
4. Recheck pressure and make additional adjustments as required.
5. Remove pressure gauge and replace 9/16" plug.

### ⚠ CAUTION

*When working on hydraulic system, cleanliness of hands, parts, tools and immediate area is essential! Introduction of any foreign material into hydraulic system may cause damage to the equipment.*

1. Remove flanged cup casting located on rear of hydraulic motor. This flanged cap contains the relief valve, spring and shims.
2. Add shims to increase relief valve setting. Pressure may be increased at a rate of 50 PSI per one thousandth (.001") of shim. Recommended pressure is 4000–4500 PSI.
3. Before replacing plug, place a dab of vaseline or petroleum jelly on end of tube to prevent parts from dropping out.
4. Recheck pressure and make additional adjustments as required.
5. Remove pressure gauge and replace 9/16" plug.

# HYDROSTATIC PUMPS AND MOTORS

## DYNAPOWER

### Type III Hydraulic Motor

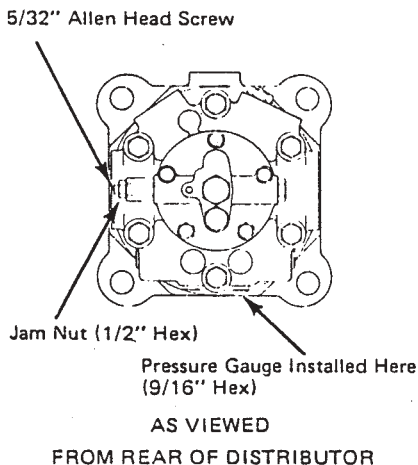


Figure 34. Type III Hydraulic Motor

1. Loosen 1/2" hex jam nut and turn 5/32" allen head screw in to increase pressure. A pressure increase of 800 PSI per turn may be expected. Recommended pressure is 4000-4500 PSI.
2. Re-tighten jam nut while holding allen head screw.
3. Recheck pressure and make additional adjustments as required.
4. Remove pressure gauge and replace 9/16" plug.

### DYNAPOWER GENERATION II UNITS

The following procedures are for making various pressure adjustments to the Dynapower Generation II Pumps and Motors.

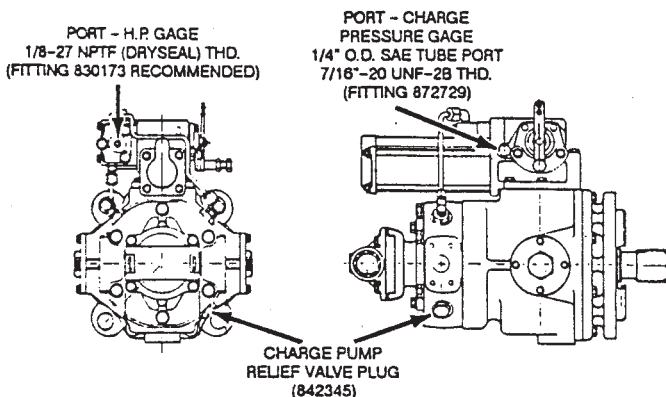


Figure 35. Generation II Pump

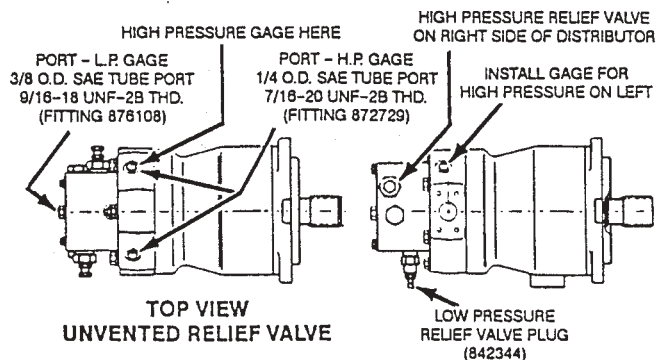


Figure 36. Generation II Motor

### Case Leakage

#### Pump

#### CAUTION

*When working on hydraulic system, cleanliness of hands, parts, tools and immediate area is essential! Introduction of any foreign material into hydraulic system may cause damage to the equipment.*

*To avoid possible damage to equipment, it is mandatory that charge pressure not fall below 200 PSI.*

1. Refer to Figures 35. and 36. Install high pressure gauges at motor and charge pressure gauge at pump control.
2. Lock hydraulic motor shaft from rotating.
3. Disconnect case return line from hydraulic pump.
4. Connect a flow meter in the case return line, or provide means to direct oil flow into a container of known volume for a measured amount of time to determine the flow rate in gallons per minute (GPM).
5. Remove charge pump relief valve plug, spring and plunger, and install blanking plug (see Figure 35.).

#### CAUTION

*To prevent damage to equipment, do not operate hydraulic system at bypass pressure for extended periods. Overheating of the oil will result, causing possible damage to the equipment. Overheating of oil also affects pressure readings.*

# HYDROSTATIC PUMPS AND MOTORS

## DYNAPOWER

6. Start power to pump with hydraulic control knob in uppermost position.
7. Push down hydraulic control knob to build up 4500 PSI system pressure. Move knob slowly as pressure should develop quickly.
8. Measure case flow. Case flow with pump operating at 1750 RPM, 4500 PSI and 140° (fluid temperature) should be 1.4 GPM (Models 48 or 60 pump), or 3.2 GPM (Model 90 Pump). If the flow rate is high, the pump is worn internally and should be replaced or repaired before proceeding.

**NOTE:** *The case flow values listed above are test stand values of a new unit. Case flow of a used pump may be slightly higher. An extremely high case flow (two to three times the rated value, for example) indicates serious leakage problems.*

9. Stop pump. Remove plug and replace plunger, spring and plug to their original position in the pump cover.

**NOTE:** *If oil was directed into a clean, dry container, the oil may be saved and returned to the reservoir.*

### Motor

#### **⚠ CAUTION**

*When working on hydraulic system, cleanliness of hands, parts, tools and immediate area is essential! Introduction of any foreign material into hydraulic system may cause damage to the equipment.*

*To avoid possible damage to equipment, it is mandatory that charge pressure not fall below 200 PSI.*

1. Lock hydraulic motor shaft from turning.
2. Disconnect case return line from hydraulic motor.
3. Connect a flow meter in the case return line, or provide means to direct oil flow into a container of known volume for a measured amount of time to determine the flow rate in gallons per minute (GPM).
4. Remove low pressure relief valve cartridge from motor cover (see Figure 36.) and install blanking plug.
5. Start power to pump with hydraulic control knob in uppermost position.

#### **⚠ CAUTION**

*To prevent damage to equipment, do not operate hydraulic system at bypass pressure for extended periods. Overheating of the oil will result, causing possible damage to the equipment. Overheating of oil also affects pressure readings.*

6. Push control knob down slightly to build up 4500 PSI system pressure. Move plunger slowly as pressure should develop quickly.
7. Measure case flow of motor. Case flow with pump operating at 1750 RPM, 4500 PSI and 140° (fluid temperature) should be 1.4 GPM (Models 48 or 60 motor). If the flow rate is high, the motor is worn internally and should be replaced or repaired before proceeding.

**NOTE:** *The case flow values listed above are test stand values of a new unit. Case flow of a used motor may be slightly higher. An extremely high case flow (two to three times the rated value, for example) indicates serious leakage problems.*

8. Stop pump. Remove blanking plug and install low pressure relief valve cartridge in motor cover.

**NOTE:** *If oil was directed into a clean, dry container, the oil may be saved and returned to the reservoir.*

### **Adjustments**

#### High Pressure Relief Valves

1. Install gauges in the high pressure ports of the motor (see Figure 36.).
2. Disconnect sense tubes if pump has override control. Cap tube fittings in cover.
3. Lock motor shaft from turning.
4. Start power to pump with hydraulic control knob in uppermost position.

#### **⚠ CAUTION**

*To prevent damage to equipment, do not operate hydraulic system at high pressures for extended periods. Overheating of the oil will result, causing possible damage to the equipment. Overheating of oil also affects pressure readings.*

5. Push control knob down slowly off neutral until pressure reaches maximum setting. Pressure should be 4500 PSI.

# HYDROSTATIC PUMPS AND MOTORS

## DYNAPOWER

6. If relief valve adjustment is necessary, loosen lock-nut of the high pressure relief valve opposite the gauge indicating pressure.
7. Operate pump to obtain maximum pressure and turn adjusting screw IN to raise pressure setting, or OUT to lower pressure setting. Tighten lock nut while holding adjusting screw and recheck pressure setting.

**NOTE:** *One full turn of the adjusting screw will change the relief valve setting approximately 1200PSI.*

### Low Pressure Relief Valve

1. Install gauge in low and high pressure ports of motor (refer to Figure 35.).
2. Lock motor shaft from turning.
3. Start power to pump with hydraulic control knob in uppermost position.
4. Push control knob down slightly to build up system pressure to 1000 PSI.
5. Observe low pressure gauge. Pressure should be 250 PSI with pump speed at approximately 1750 GPM.
6. If adjustment is necessary, loosen nut on low pressure relief valve and turn adjusting screw IN to raise pressure setting or OUT to lower pressure setting. Tighten lock nut while holding adjusting screw and recheck pressure setting.

**NOTE:** *One full turn of the adjusting screw will change setting approximately 35 PSI.*

### Controls

**NOTE:** *High pressure relief valves must be set 500 PSI above Control setting before attempting to set control. Factory setting of full cut-off pressure is indicated on control name plate. Example: 892XXX-45 indicates full cut-off control setting of 4500 PSI.*

1. Short Differential (Pressure Limiting)
  - a. Install high pressure gauge in high pressure port of pump control (refer to Figure 35.).
  - b. Lock motor shaft from turning.
2. Long Differential (Input Torque Limiting)
  - a. Install high pressure gauge in high pressure gauge port of pump control (refer to Figure 35.).
  - b. Lock motor shaft from turning.
  - c. Start power supply to pump with hydraulic control knob all the way up.
  - d. Push control knob down slowly until pressure reaches maximum setting. Observe pressure gauge.
  - e. To adjust full cut-off pressure setting on models 90, 120 and 210, loosen lock nut on socket head screw on top of control. Moving indicator mark on socket head screw toward pump cover decreases pressure; toward flange increases pressure. Tighten lock nut.
  - f. On Models 48 and 60, full cut-off adjustment is accomplished by shimming the control sleeve.
  - g. Recheck full cut-off control setting in both directions and re-adjust if necessary.

**NOTE:** *One full turn of adjusting screw will change pressure approximately 1000 PSI.*

**NOTE:** *Only full cut-off pressure can be adjusted. Do not adjust screw on end of control. This is factory set for input torque (horsepower) curve.*

# HYDROSTATIC PUMPS AND MOTORS

## SUNDSTRAND

### START-UP AND MAINTENANCE

#### Fluids

Hydraulic fluids used with Sauer-Sundstrand products should be carefully selected with assistance from a reputable supplier.

#### Start-Up Procedure

The following start-up procedure should always be followed when starting-up a new Series 90 installation, or when restarting an installation in which either the pump or motor has been removed from the system.

1. Prior to installing the pump and/or motor, inspect the units for damage incurred during shipping and handling. Ensure all system components (hoses, valves, fittings, etc.) are clean prior to filling with fluid.
2. Fill the reservoir with recommended hydraulic fluid which should be passed through a 10-micron (nominal, no bypass) filter prior to entering the reservoir. The use of contaminated fluid will cause damage to the components.
3. The inlet line from the reservoir to the pump must be filled prior to start-up. Check inlet line for properly tightened fittings, and ensure it is free of restrictions and air leaks.

#### CAUTION

*Be sure to fill the pump and/or motor housing with clean hydraulic fluid prior to start-up. Failure to heed this caution will result in damage to the hydraulic pump and/or motor.*

4. Fill the pump and/or motor housing by pouring filtered oil into the upper case drain port.
5. Install a 0 to 500 psi (35 BAR) pressure gauge in the charge pressure gauge port to monitor charge pressure during start-up.
6. Disconnect control linkage from pump to ensure pump remains in neutral position.

#### CAUTION

*Do not start prime mover unless pump is in neutral position. Damage to equipment may result.*

7. "Jog" or slowly rotate the prime mover (engine) until the charge pressure starts to rise. Start the prime mover and run at the lowest possible RPM until charge pressure has been established. Excess air may be bled from the high pressure lines through the high pressure gauge ports.
8. Once charge pressure has been established, increase speed to normal operating RPM. Charge pressure should be 320 PSI (23 BAR) minimum. If charge pressure is incorrect, shut down system and determine cause for improper pressure.

#### WARNING

**Inadequate charge pressure will affect the operator's ability to control pump output.**

9. Shut down engine and connect pump control linkage. Start engine and check to be sure pump remains in neutral position. With engine at normal operating speed, slowly check forward and reverse functions of pump and/or motor.
10. Charge pressure should remain at 320 to 340 PSI (23 to 24 BAR) minimum during forward and reverse operation. Continue to cycle slowly between forward and reverse for at least five (5) minutes.
11. Shut down engine, remove gauges and plug ports. Check reservoir and add fluid as necessary.

#### Maintenance

To insure optimum service life from Series 90 products, regular maintenance of the fluid and filter must be performed.

Check the reservoir daily for the following:

1. Proper fluid level.
2. The presence of water (indicated by cloudy or milky appearance or free water in the bottom of the reservoir).
3. Rancid fluid odor (indicating excessive heat).

It is recommended that the fluid and filter be changed per the following schedule:

1. System with a sealed reservoir: Every 2000 hours.
2. System with a breathing type reservoir: Every 500 hours.

# HYDROSTATIC PUMPS AND MOTORS

## SUNDSTRAND

It may be necessary to change the fluid more frequently than the above intervals if the fluid becomes contaminated with foreign matter (dirt, water, grease, etc.) or if the fluid has been subjected to temperatures higher than the maximum recommended. Never reuse hydraulic fluid.

The filter should be changed whenever the fluid is changed, or whenever the filter indicator shows that it is necessary to change the filter.

### TROUBLESHOOTING

#### Gauge Installation

Various pressure and vacuum gauge readings can be helpful in troubleshooting problems with the Series 90 hydraulic components.

It will be necessary to install a high pressure gauge into the system pressure gauge ports to check the high pressure setting of the multi-function valves.

Measuring the charge pump inlet vacuum will help locate restrictions in the inlet lines, filter, etc.

Case pressure readings can help locate restrictions in the return lines, oil cooler, and return filter.

**NOTE:** *Snubbers are recommended to protect pressure gauges. Frequent gauge calibration is necessary to insure accuracy.*

GAUGE INSTALLATION		
A	System Pressure Port "A"	Gauge: 10,000 PSI (690 BAR) Fitting: 9/16 - 18 O-Ring
B	System Pressure Port "B"	Gauge: 10,000 PSI (690 BAR) Fitting: 9/16 - 18 O-Ring
C	Charge Pressure	Gauge: 500 PSI (35 BAR) Fitting: 9/16 - 18 O-Ring or Tee into Charge Pressure Filter Outlet Line
D	Case Pressure	Gauge: 500 PSI (35 BAR) Fitting: See Chart Below
E	Charge Pump Inlet Vacuum	Gauge: Vacuum Fitting: 9/16 - 18 O-Ring or Tee into Charge Pressure Filter Outlet Line
F	Servo Pressure	Gauge: 500 PSI (35 BAR) Fitting: 9/16 - 18 O-Ring or 7/16 - 20 O-Ring
G	Servo Pressure	Gauge: 500 PSI (35 BAR) Fitting: 9/16 - 18 O-Ring or 7/16 - 20 O-Ring

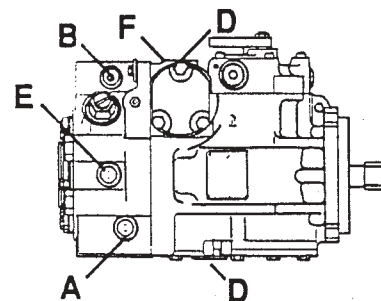


Figure 37. Gauge Connections – Variable Pump with Radial Port End Cap

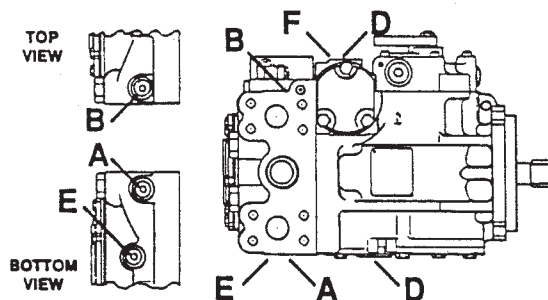


Figure 38. Gauge Connections – Variable Pump with Twin Port End Cap

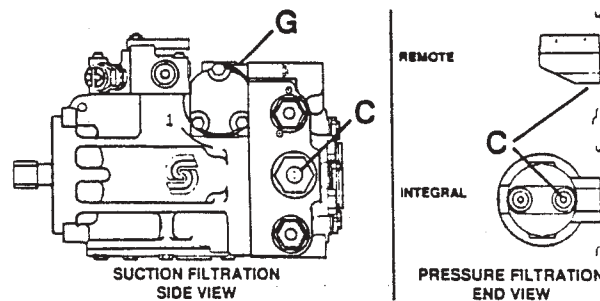


Figure 39. Gauge Connections – Variable Pump

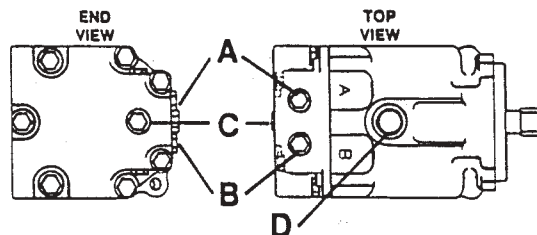


Figure 40. Gauge Connections – Fixed Motor



# HYDROSTATIC PUMPS AND MOTORS

## SUNDSTRAND

**Case Drain Port Sizes**

Frame Size	Pump	Motor
030	7/8 - 14 O-Ring Fitting	—
042	7/8 - 14 O-Ring Fitting	—
055	1-1/16 - 12 O-Ring Fitting	7/8 - 14 O-Ring Fitting
075	1-1/16 - 12 O-Ring Fitting	1-1/16 - 12 O-Ring Fitting
100	1-1/16 - 12 O-Ring Fitting	1-1/16 - 12 O-Ring Fitting
130	1-5/16 - 12 O-Ring Fitting	1-5/16 - 12 O-Ring Fitting

### INSPECTIONS AND ADJUSTMENTS

#### Manual Displacement Control (MDC)

There are no adjustable elements in the manual displacement control. All functions are preset at the factory.

#### Hydraulic Displacement Control (HDC) Neutral Adjustment

The neutral adjustment is the only adjustment that can be made on the hydraulic displacement control; all other functions are preset at the factory. The neutral adjustment of this control must be made on a test stand or on the vehicle with the engine operating.

### **WARNING**

**To prevent severe injury from becoming entangled in machinery, stand clear of rotating drives.**

1. Install two (2) 500 PSI (35 BAR) gauges in the servo gauge ports (one on each side). Start the engine and operate at normal speed.

2. For earlier production controls, loosen the lock nut on the neutral shaft with a 17 mm hex wrench. For later production controls, loosen the lock nut on the neutral adjusting screw with a 10 mm hex wrench.
3. Use a 5 mm internal hex wrench to turn the neutral shaft on earlier production controls, or a 3 mm internal hex wrench to turn the neutral adjusting screw on later production controls.
4. Rotate the neutral adjusting shaft or the neutral adjusting screw clockwise until the pressure increases in one of two pressure gauges. Note the location "A" (angular position) of the internal hex wrench.
5. Without removing the internal hex wrench, rotate the neutral shaft or adjusting screw counter-clockwise until the pressure increases in the other gauge. Note the location "B" (angular position) of the internal hex wrench.
6. Rotate the neutral shaft or adjusting screw clockwise half the distance between locations "A" and "B". The control should now be in neutral. In this position both gauges should read the same pressure (case pressure).
7. While holding the neutral shaft or adjusting screw stationary with the internal hex wrench, tighten the neutral shaft lock nut (earlier production controls) to 16 ft. lbs. (22 Nm), or the neutral adjusting screw lock nut (later production controls) to 60 in. lbs. (7 Nm). Do not over-torque the locknut.
8. With the neutral position set, stop the engine, remove the gauges and install the gauge port plugs.

#### Electric Displacement Control (HDC) Neutral Adjustment

The adjustment procedures for the Electric Displacement Control are the same as the procedures for adjusting the hydraulic displacement control listed above.

# GENERAL FUEL DATA AND HEATING TERMINOLOGY

## FUEL DATA

FUEL	WEIGHT PER GALLON	BTU CONTENT
Propane	4.38 lbs	91,800 per gallon
#2 Fuel Oil	7.49 lbs.	144,300 per gallon
Kerosene	6.97 lbs.	134,500 per gallon

### APPROXIMATE BURNER FUEL CONSUMPTION

**Propane** 1,000,000 BTU @ 40 PSI  
(91,500 BTU per gallon)  
One 100-pound bottle contains 23 gallons

For each burner     @ 15 PSI - 5 GPH  
                              @ 20 PSI - 6 GPH  
                              @ 25 PSI - 7 GPH  
                              @ 30 PSI - 8.2 GPH  
                              @ 35 PSI - 9.5 GPH  
                              @ 40 PSI - 11 GPH

### Low Pressure Fuel Oil

935,000 BTU @ 20 PSI  
6.5 GPH per burner  
(144,000 BTU per gallon)

### Kerosene Generating

575,000 BTU @ 40 PSI  
4.25 GPH per burner  
(135,000 BTU per gallon)

## HEATING TERMINOLOGY

### Flash Point (Open Cup)

The temperature at which a flammable liquid in an open container emits vapor that will flash when exposed to a direct flame. This temperature is lower than required for the liquid mass to ignite.

### Closed Flash Point

The temperature at which a flammable liquid in a closed container emits a vapor that will flash when exposed to a direct flame. This temperature is lower than required for the liquid mass to ignite. The closed flash point is generally 30° (F) lower than the open cup flash point.

### Fire Point

The temperature at which a flammable liquid emits a vapor at a rate that will continue to burn after it has flashed.

### Ignition Temperature (Kindling Temperature)

The lowest temperature at which a combustible material will continue to burn once ignited.

### Convection

Heat transfer by a flow of a liquid or gas over a solid material. Example: Flues in asphalt tank are heated from hot gases passing through them, or, heat transfer coils in a tank are heated from steam or hot oil passing through them.

### Conduction

Heat transfer through a solid mass by direct molecular contact. Example: Heat applied only to one end of a metal rod will be transferred throughout the entire body by molecular transfer.

# ACCEPTABLE HYDRAULIC FLUIDS

The following are considered to be ACCEPTABLE for use in DYNAPOWER hydraulic pumps and motors.

Source: Dynapower Engineering Bulletin  
No. DEB-101  
January 3, 1989

Acceptable fluids are not necessarily recommended to be combined. Please check with your oil or fluid distributor for mixable fluids.

Vendor	Description	Viscosity SSU at 130°F
AMS-Oil, Inc.	Synthetic Multi Functional Farm Tractor Hydraulic Oil	170.0
	Synthetic Hydraulic Oil	98.0
Ashland Oil Co.	"Unitrac" Valvoline Fluid	155.0
Amalie Refining Co.	XLO SAE 10W	102.0
	Dexron II	105.0
	AMA-Oil R & O 200 AW	95.0
Allied Tire Co.	Allied Superior AW Ind Hyd 100	194.0
Chevron USA, Inc.	Tractor Hyd. Fluid	134.0
CITGO Petr'l Corp	CITGO ATF Dexron II	106.0
	ATF Type F	107.0
Exxon Co. USA	Univis N46	132.0
Fiske Bros.	Lubriplate UTF-C-3 Oil	133.0
Gopher Oil Co.	Univ. Super Tractor Fluid	150.0
Lubrication Engineers	1107 ATF Fluid Dexron II	97.0
Mobil Oil Corp.	Mobil SHC 626 Oil	181.0
	Mobil Fluid 300	89.0
	Mobil Universal ATF	113.0
	Mobil Delvac 1110	101.0
	Mobil Delvac 1310	107.0
	Mobil SHC 525	136.0
	Mobil SHC 526	158.0

Vendor	Description	Viscosity SSU at 130°F
Mobil Oil Corp. (Cont'd)	Mobil DTE 16M	157.0
	Mobil DTE-24	90.0
	Mobil SCH-524	88.0
	Mobil DTE 15M	131.0
	Mobil DTE-25	125.0
	Mobil DTE-26	157.0
Penzoil Prod.	Hydra-Tranz	96.0
	Hydra-Flow Dexron II	96.0
Phillips Petroleum	ATF (F) HG Fluid	109.0
Sun Refining	Hyd. Sun Oil 2105	122.0
Shell Canada Ltd.	Shell Tellus 32	92.0
Texaco, Inc.	Rando HD46	111.0
	ATF Dexron II Code #1841	117.0
	Texaco 2319 Merops 68PA	164.0
	1026	

The following fluids are considered to be ACCEPTABLE for the 4.5, 6.0, 12.0 and 21.0 CIR Qualified Products List units, when operating within the maximum operating conditions for which they were qualified, as shown on Qualified Products List QPL-17869 (Dynapower).

Vendor	Description	Viscosity SSU at 130°F
MIL-L-17672	2075-T-11	82.0
Houghton	1177 (2075)	85.0

# LUBRICATION CHART

INTERVAL	POINT	IDENTIFICATION	LUBRICANT	QUANTITY
30 DAYS	1	Bell Mechanism	EO*	Sparingly
	2	Manhole Cover	EO*	Sparingly
	3	Inside Valve Handwheel	EO*	Sparingly
	4	Spray Bar Controls	EO*	Sparingly
	5	Tachometer Cable	GO	Fill
	6	Bar Turn Up Bearings	MPG	Sparingly
	7	Bar Carrying Mechanism	EO* & MPG	Sparingly
	8	Transmission	#90M-ATG	1-3/4 Qts.
	9	Pump Coupling	#2M-AG	Sparingly
	10	Bitumeter Wheel	EO*	Sparingly
	11	Bitumeter Cable	GO	Fill
DAILY	12	Air Relief Valve	EO*	Sparingly
	25	Flip Valve Lever	MPG	Sparingly
	27	Clutch Throw-Out Bearing	MPG	Sparingly
	13	Oil Bath Air Cleaner Engine & Blower	EO	Fill to Line
	14	Blower Gear Case	EO	7 Oz.
	15	Blower Clutch Drive	EO*	Sparingly
	16	Drive Universals	#2M-AG	Sparingly
	17	Control Linkage	EO*	Sparingly
	18	Pump Universal	#2M-AG	Sparingly
	19	Tachometer Drive Chain	EO*	Sparingly
	20	Hydraulic Reservoir	HTF	3/4 Full**
ANNUALLY	21	Gasoline Engine	KER	See Eng. Manual
	22	V-Belt Sheave Idler Brg.		Wash Twice Yearly
	23	Hydraulic Oil Filter		Replace if vacuum gauge shows in red area
	24	Pump Discharge Strainer		Clean Weekly
ANNUALLY	26	Pump Spline Fitting Yoke	#67-71	

- #67-71: Anti-seize Compound
- #2M-AG: #2 Molub Alloy Grease
- #90M-ATG: #90 Molub Alloy Transmission Grease
- MPG: Multipurpose Type Grease
- HFT: Hydraulic Transmission Fluid - Type A
- GO: Graphite Oil
- EO: Engine Crankcase Oil
- EO\*: Engine Crankcase Oil/Applied w/Oil Can
- KER: Kerosene

**NOTE:** On units with one man air controls - fill line oiler, located on outlet side of air reservoir, with light oil as needed. Also wipe cylinder rods clean and lightly oil. Drain water from air reservoir daily.

\*\*Fill completely for winter storage. This will prevent condensation in reservoir. Drain down to thermometer hole prior to use.

