

M-102-03
Serial Number S3400 And Up



Black-Topper® CENTENNIAL with Analog Gages Asphalt Distributor



Operation



Maintenance



Safety

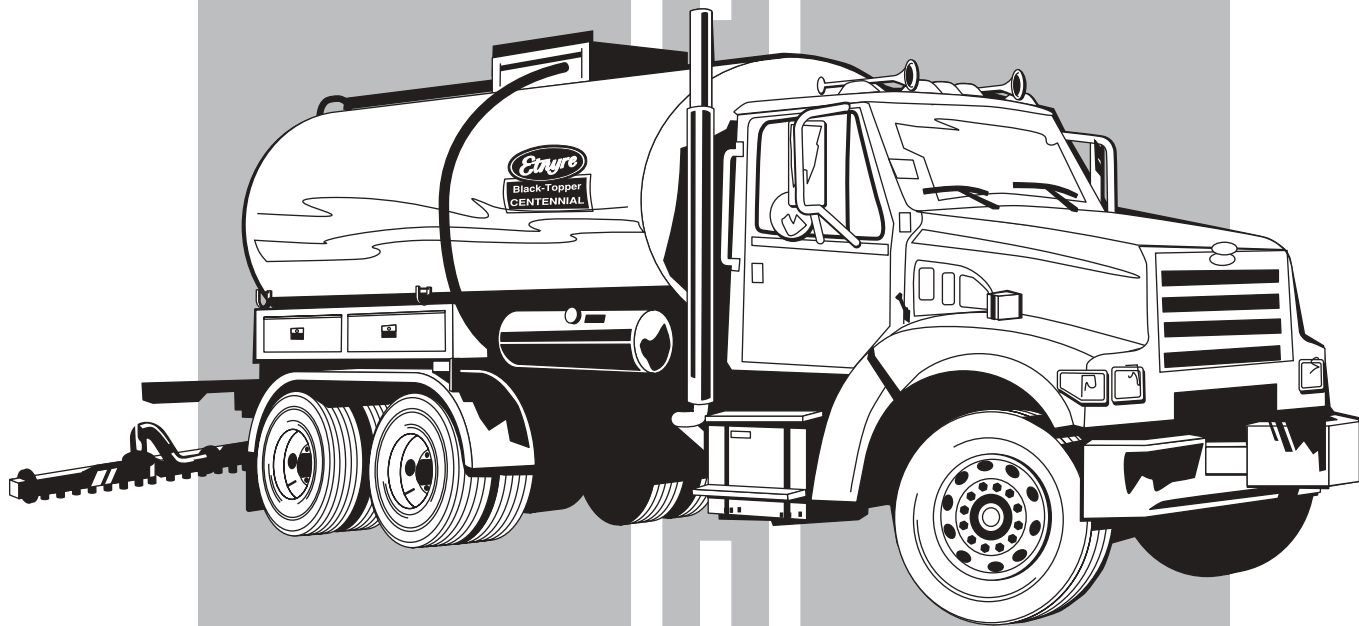

E. D. ETNYRE & CO. 1333 S. Daysville Road, Oregon, Illinois 61061
Phone: 815/732-2116 or 800/995-2116 • Fax: 800-521-1107 • www.etnyre.com

**WARNING**

Do not use this machine for any operation which is not described in this manual. If you have any questions about operation of this machine, contact the Etnyre Service Department at 1-800-995-2116 or 1-815-732-2116. Operations that are not approved could cause serious injury or death.

PROPOSITION 65 WARNING

Diesel Engine exhaust and some of its constituents are known to the State of California to cause cancer, birth defects, and other reproductive harm.

Please note this warning and remember -

Always start and operate the engine in a well-ventilated area;

If in an enclosed area, vent the exhaust to the outside;

Do not modify or tamper with the exhaust system.

**WARNING****Fluoroelastomer handling**

Some "O" rings and seals used in this vehicle are made from fluoroelastomers. When used under design conditions, fluoroelastomers do not require special handling. However, when fluoroelastomers are heated to temperatures beyond their design temperature (around 600 degrees Fahrenheit), decomposition may occur with the formation of hydrofluoric acid. Hydrofluoric acid can be extremely corrosive to human tissue if not handled properly.

A degraded seal may appear as a charred or black sticky mass. Do not touch either the seal or the surrounding equipment without wearing neoprene or PVC gloves if degradation is suspected. Wash parts and equipment with 10% lime water (calcium hydroxide solution) to neutralize any hydrofluoric acid.

If contact with the skin occurs, wash the affected areas immediately with water. Then rub a 2.5 calcium gluconate gel into the skin until there is no further irritation, while seeking prompt medical attention.

Note to physicians: For advice or treatment of HF Burns, call the DuPont Medical Emergency Number 1-800-441-3637.

Black-Topper Centennial Operation Maintenance and Safety Manual

WARRANTY

E. D. Etnyre & Co. warrants to the original Purchaser, it's new product to be free from defects in material and workmanship for a period of twelve (12) months after date of delivery to original Purchaser. The obligation of the Company is limited to repairing or replacing any defective part returned to the Company and will not be responsible for consequential damages or any further loss by reason of such defect.

The company excludes all implied warranties of merchantability and fitness for a particular purpose. There are no warranties, express or implied, which extend beyond the description of the goods contained in this contract.

This warranty does not obligate the Company to bear the cost of machine transportation in connection with the replacement or repair of defective parts, nor does it guarantee repair or replacement of any parts on which unauthorized repairs or alterations have been made or for components not manufactured by the Company except to the extent of the warranty given by the original Manufacturer.

This warranty does not apply to:

- (1) Normal startup services, normal maintenance services or adjustments usually performed by the selling dealer, factory service representative or customer personnel.
- (2) Any product manufactured by E. D. Etnyre & Co. purchased or subjected to rental use.
- (3) Any product or part thereof which shows improper operation, improper maintenance, abuse, neglect, damage or modification after shipment from factory.
- (4) Any product or part thereof damaged or lost in shipment. Inspection for damage should be made before acceptance or signing any delivery documents releasing responsibility of the delivering carrier.

This warranty and foregoing obligations are in lieu of all other obligations and liabilities including negligence and all warranties of merchantability or otherwise, express or implied in fact or by law.

| |
|--|
|  WARNING |
| Do not use this machine for any operation which is not described in this manual. If you have any questions about operation of this machine, contact the Etnyre Service Department at 1-800-995-2116 or 1-815-732-2116. Operations that are not approved could cause serious injury or death. |

| |
|---|
| CALIFORNIA Proposition 65 WARNING Diesel engine exhaust and some of its constituents are known to the State of California to cause cancer, birth defects, and other reproductive harm. |
|---|

- Please note this warning and remember -
- Always start and operate the engine in a well ventilated area;
 - If in an enclosed area, vent the exhaust to the outside;
 - Do not modify or tamper with the exhaust system.

| |
|---|
|  WARNING |
| Fluoroelastomer Handling |
| Some O-rings and seals used in this vehicle are made from fluoroelastomers, When used under design conditions, fluoroelastomers do not require special handling. However, when fluoroelastomers are heated to temperatures beyond their design temperature (around 600° Fahrenheit), decomposition may occur with the formation of hydrofluoric acid. Hydrofluoric acid can be extremely corrosive to human tissue if not handled properly. A degraded seal may appear as a charred or black sticky mass, Do not touch either the seal or the surrounding equipment without wearing neoprene or PVC gloves if degradation is suspected. Wash parts and equipment with 10% lime water (calcium hydroxide solution) to neutralize any hydrofluoric acid. If contact with the skin occurs, wash the affected areas immediately with water. Then rub a 2.5 calcium gluconate gel into the skin until there is no further irritation, while seeking prompt medical attention. Note to Physicians: For advice or treatment of HF burns, call the DuPont Medical Emergency number, 1-800-441-3637 |

TABLE OF CONTENTS



| | | | |
|---|----|---|----|
| Warning And Instruction Plates | 3 | General Fuel Data And Heating Terminology | 45 |
| General Safety Instructions | 4 | Fuel Data | 45 |
| Safety Precautions, Hazard Seriousness Level | 4 | Approximate Burner Fuel Consumption | 45 |
| Introduction | 7 | Low Pressure Fuel Oil | 45 |
| Reporting Safety Defects | 7 | Kerosene Generating | 45 |
| Component Location And Identification | 8 | Heating Terminology | 45 |
| Hydraulic Tank and Components | 9 | Flash Point (Open Cup) | 45 |
| Spray Bar Component Identification | 9 | Closed Flash Point | 45 |
| Cab Control panel | 11 | Fire Point | 45 |
| Rear Control panel | 14 | Ignition Temperature (Kindling Temperature) | 45 |
| Etnyre Computator | 16 | Convection | 45 |
| Preparing for Operation | 16 | Conduction | 45 |
| Engaging Pump on PTO Equipped Distributors | 17 | Hydraulic Fluid Requirements | 46 |
| Foaming | 17 | General Information | 46 |
| Asphalt Institute | 17 | Hydraulic fluid requirements | 46 |
| General | 19 | Viscosity & Temperature Requirements | 46 |
| Tank Capacity | 19 | Contamination Levels | 47 |
| Mixing Dow-Corning DC-200 Anti Foam Agent | 19 | Lubrication Chart | 48 |
| Filling Through the Fill Line | 19 | Tach Calibration | 49 |
| Connections and Preliminary Checks | 19 | Etnyre Spraybar Nozzles | 50 |
| Filling from the Cab | 20 | | |
| Filling from the Rear Control Panel | 21 | | |
| Filling through the Manhole | 22 | | |
| Circulating Product in the Tank | 23 | | |
| Circulating in the tank from the cab | 23 | | |
| Circulating in the Tank from the Rear Control Panel | 24 | | |
| Circulating Product in the Bar | 25 | | |
| Spraying Operations | 25 | | |
| Adjusting the Spray Bar Nozzle Angle | 26 | | |
| Adjusting the Spray Bar Height | 26 | | |
| Spraying through the Bar | 26 | | |
| Suckback from the Cab | 28 | | |
| Handspraying | 29 | | |
| Suck Back for Hand Spray Operations | 30 | | |
| Pump Off Operations | 31 | | |
| Transfer Operations | 32 | | |
| Flushing Operations | 33 | | |
| Heating Asphalt with Liquid Propane (LPG) Burners | 34 | | |
| LPG Supply Tank Requirements | 34 | | |
| Manual Control Burners | 34 | | |
| Burner Operation | 34 | | |
| Burners With Outfire Controls | 36 | | |
| Burner Operation with Outfire Controls | 36 | | |
| Burners with Auto Ignition & Temp Limiting Control | 38 | | |
| Burner Operation with Auto Ignition & Temp Control | 38 | | |
| Electric Driven Burner Operation | 39 | | |
| Troubleshooting | 40 | | |
| Maintenance | 42 | | |
| Electrode Assembly Adjustments | 42 | | |
| Burner Air Band Settings | 42 | | |
| Check Ignition Transformer Spark | 42 | | |
| Fire Burners | 43 | | |
| Replacing Speed Pickup | 43 | | |
| Adjusting Spray Bar Nozzle Angle | 43 | | |
| Adjusting Spray Bar Height | 43 | | |
| Servicing The Etnyre P-15 Pump | 44 | | |
| Vacuum Check | 44 | | |
| Pump Disassembly And Inspection | 44 | | |
| Impeller Installation And Pump Assembly | 44 | | |

List Of Illustrations

| | |
|--|----|
| Etnyre Computator | 16 |
| Figure 1. Using the Measuring Stick | 20 |
| Figure 2. Valve Positions - Filling Thru the Fill Line | 21 |
| Figure 3. Valve Positions - Filling Thru the Manhole | 22 |
| Figure 4. Valve Positions - Circulating in the Tank | 23 |
| Figure 5. Valve Positions - Circulating in the Bar | 24 |
| Figure 6. Adjusting the Spray Bar Nozzles | 26 |
| Figure 7. Adjusting the Spray Bar Height | 26 |
| Figure 8. Valve Positions - Spraying Thru the Bar | 27 |
| Figure 9. Valve Positions - Suck Back the Spray Bar | 28 |
| Figure 10. Valve Positions - Handspray | 29 |
| Figure 11. Valve Positions - Handspray Suckback | 30 |
| Figure 12. Valve Positions - Pump Off | 31 |
| Figure 13. Valve Positions - Transfer | 32 |
| Figure 14. Valve Positions - Flushing | 33 |
| Figure 15. Manual Control Burner System | 35 |
| Figure 16. Outfire Controlled Burner System | 37 |
| Figure 17. Burner with Auto Ignition & Temp Cont | 38 |
| Figure 18. Electric Burner System | 39 |
| Figure 19. Burner Electrode Adjustments | 42 |
| Figure 20. Electrode Assembly Installation | 42 |
| Figure 21. Nozzle Adjustment | 42 |
| Figure 22. Nozzle Angle Adjustment | 43 |
| Figure 23. Nozzle Height Adjustment | 43 |
| Figure 24. Etnyre Asphalt Pump | 44 |
| Figure 25. Serial Number Plate Location | 51 |

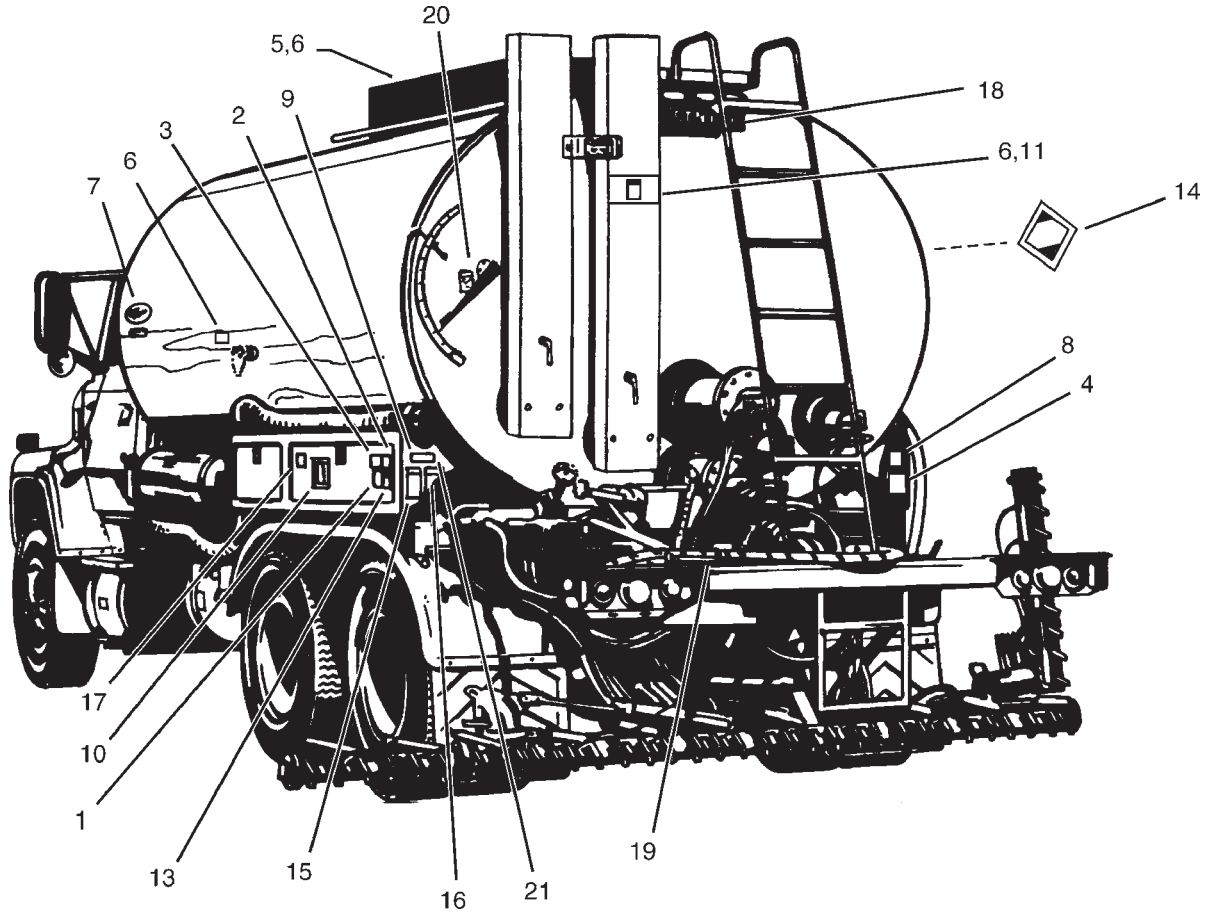
Warning And Instruction Plates



-  For operator safety and possible liability protection, all Safety and Instruction Plates should remain in place and be legible
-  Should a plate be removed, lost, or become illegible, reorder and replace immediately
-  If plates become difficult to read because of material coating the surface, clean with solvent

| REF | PART NO. | QTY | DESCRIPTION | REF | PART NO. | QTY | DESCRIPTION |
|-----|----------|-----|--|-----|----------|-----|-------------------------------------|
| 1 | 3390683 | 1 | Plate- Caution, Shields in Place | 11 | 3390592 | 1 | Bracket- Mtg, Caution, Hot Surface |
| 2 | 3390681 | 1 | Plate- Caution, Remain Clear of | 12 | 6100139 | AR | Rivet- Pop, 0.12, Not Shown |
| 3 | 3390682 | 2 | Plate- Caution, Before Starting | 13 | 3390620 | 2 | Plate- Warning, Manuals |
| 4 | 3390686 | 1 | Plate- Warning, Burner, General | 14 | 6320056 | AR | Placard System (Optional) |
| 5 | 3390679 | 2 | Plate- Warning, Manhole | 15 | 3390636 | 1 | Plate- Warning, Flues Covered |
| 6 | 3390684 | 3 | Plate- Caution, Hot Surface | 16 | 3390637 | 1 | Plate- Warning, Asphalt Grades |
| 7 | 3390696 | 2 | Decal, BlackTopper Centennial | 17 | 3390655 | 1 | Plate- Name, Distributor S/N, Brass |
| 8 | 3390540 | * | Plate- Directions, LPG Burner | 18 | 3390149 | 1 | Plate- Name, Etnyre |
| | 3390670 | * | Plate- Directions, Elect Beckett Burners | 19 | 3390591 | 1 | Tag-Caution, Handspray Hose |
| 9 | 3390680 | 1 | Plate- Warning, Fill Cap | 20 | 3390659 | 1 | Decal-Warning, GVWR |
| 10 | 3390685 | 1 | Plate- Warning, Safety, General | 21 | 3390669 | 1 | Decal-Handspray Operation |

General Safety Instructions

The operation of a Bituminous Distributor normally requires handling of liquid products at elevated temperature. Also, these liquids may be of a volatile nature. A heating system is supplied to raise or maintain the product temperature, and these systems use highly combustible fuels. As with any type of construction equipment, there are certain hazards associated with careless or improper operation.

Safety warnings have been provided to call attention to any potentially hazardous situation that may cause property damage, personal injury or death to the operator or bystanders. These safety warnings will be shown at various times throughout this manual, as they are applicable to the subject being presented. These safety warnings are identified by the following warning symbols:

Safety Precautions, Hazard Seriousness Level

You will find safety information boxes throughout this manual. These boxes contain information alerting you to situations or actions to avoid.

Signal words (DANGER, WARNING and CAUTION) are used to identify levels of hazard seriousness. Their selection is based on the likely consequence of human interaction with a hazard. Definitions of hazard levels are as follows.



DANGER - Immediate hazards which **will** result in severe personal injury or death.



WARNING - Hazards or unsafe practices which **could** result in severe personal injury or death.



CAUTION - Hazards or unsafe practices which could result in minor personal injury or product or property damage.

All of these warnings are listed below and they also appear throughout the manual. In addition to these, you will find notes throughout the manual.

NOTE - A note provides general information that the operator should be aware of when performing an operation.



DANGER

To avoid an extreme fire hazard or explosion, NEVER use gasoline as fuel in low pressure or generating burners.



WARNING

A fully charged dry chemical type fire extinguisher must be within easy reach whenever the burners are operating or there is an open flame near the distributor. The minimum capacity of the fire extinguisher should be 10 pounds.

 **WARNING**

To prevent an explosion or fire hazard: Position the unit broadside to the wind to prevent volatile fumes from drifting toward the burners.

To prevent an explosion or fire hazard: Do not operate the burners if the tank is damaged or leaking

To prevent an explosion or fire hazard: Ensure that the burners are extinguished before removing any material from the tank in any manner. Liquid petroleum (LP) burners can support a flame for several minutes after the fuel supply is turned off.

To prevent an explosion: Do not operate the burners when the vehicle is unattended, when the vehicle is in motion, or with the vehicle in a confined area.

To prevent an explosion or fire hazard: When the burners go out, shut off the fuel supply to both burners and allow the flues to ventilate for at least 3 minutes before re-lighting the burners.

To prevent an explosion or fire hazard: Do not heat the material beyond the manufacturer's recommended temperature.

To prevent an explosion or fire hazard: Keep burning cigarettes or other sources of combustion away from manholes and overflow vents.

To prevent possible hand or facial burns: Always light the inside burner first. Do not reach across a lit burner to light or re-light the inside burner. Shut off the outside burner before lighting the inside burner.

To prevent possible burns: Always use a torch to light the burners. Never attempt to light the burners using a match or pocket lighter.

 **WARNING**

To prevent an explosion or fire hazard: Check the tank vent to insure that it is free from obstruction before lighting the burners.

To prevent an explosion or fire hazard: Do not operate the burners with the manhole open or open the manhole while the burners are in operation.

To prevent possible burns to operators or bystanders, or possible equipment damage, do not start any operation if any control settings are unknown.

To prevent possible burns from leaking material: Be sure all pipe, cap and hose connections are secure before opening valves, or beginning any operation.

To prevent possible burns from hot asphalt spray: Do not stand, or allow anyone to stand, where accidental opening of a valve may cause contact with hot asphalt.

To prevent an explosion or fire hazard: Keep area free of all sources of combustion when spraying.

To prevent possible burns from foaming or violent eruption, do not load tank with material temperature over 200°F if water or condensation is present in tank, or if emulsion was used in the previous load. Do not heat material over 200°F if moisture or emulsified material is present in tank.

To prevent an explosion or fire hazard: Eliminate sparks from engine exhaust.

To prevent burns from hot asphalt when handspraying: Hold the handspray gun in proper position and watch for other people.

To prevent burns: Always wear insulated gloves when handling spray bar sections or hoses.

WARNING

To prevent severe injury from becoming entangled in machinery: Stand clear of rotating drives.

To prevent possible injury: Always open the manhole cover slowly. Pressure build up in the tank may cause the cover to burst open.

To prevent possible fire hazards, burns or falls: Keep the unit clean for safe operation.

To prevent possible burns from material overflow: Allow sufficient space in the tank for expansion of the material when heating

Before removing the fill line cap, make certain that the asphalt pump is turning and the suction valve is closed.

To prevent possible personal injury: Do not load the vehicle beyond the GAWR or GVWR. The maximum load volume must be calculated based on material density

To prevent possible burns: Use extreme caution when using a torch to heat the pump. Asphalt accumulated around the pump may ignite when heating the pump with a torch

Allowing the burners to operate for a long period of time without circulating can damage the product and create explosive fumes. If product cannot be circulated after fifteen minutes of heating without circulation, the burners should be extinguished for 20 - 30 minutes before re-lighting the burners.

To prevent burns: Always wear eye protection, long sleeve shirt, insulated gloves, boots, and long pants outside the boots when working around the distributor.

To prevent an explosion or fire hazard: Flues must be covered by a minimum 6 inches of material (bitumen) when burners are in operation

WARNING

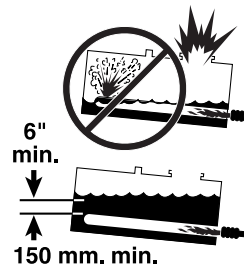

Do not light burners unless flues are covered. Explosion can occur causing death or serious injury.

Lower Burner

Lit. Gal.

Upper Burner

Lit. Gal.

3390636

WARNING

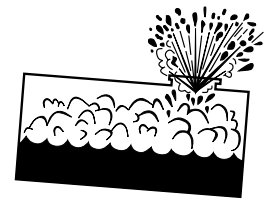

Do not change asphalt grades without reading operators manual. Explosion can occur causing death or serious injury.

3390637

Use the measuring stick as shown in figure 2 on page 21 to determine the amount of product in the tank before lighting burners. The minimum amounts shown on the warning placard only apply if the tank is level. **Remember that the measuring stick is accurate only when the tank is level.** If the tank is not level, reposition the distributor to place the tank in a level position before taking final measurement. You must have at least the amounts shown, with the tank level, in order to safely light the lower burner and upper burner respectively. **Failure to have the appropriate amount, accurately measured can result in an explosion causing death or serious injury.**

Introduction

Your Etnyre Blacktopper Centennial Distributor is designed to give you many years of accurate, dependable, and economic service. The following instructions will enable you to receive the maximum performance from your Blacktopper Centennial Distributor.

The Blacktopper Centennial Distributor's controls are designed for simple operation. They require a minimum of training for proficient usage. The exclusive Etnyre circulating system is designed and built for handling all grades of bituminous materials efficiently.

This manual is provided as a tool to aid personnel in the operation of the Etnyre Blacktopper Centennial Distributor in a safe and efficient manner. As with any type of construction equipment, there are certain hazards associated with improper or careless operation. The ability to read and understand the instructions in this manual should be a required qualification to become an operator. There are also functions that require a certain amount of physical strength to accomplish. Persons lacking the required strength may not only place themselves in jeopardy, but also others in the vicinity.

This manual covers standard features and options for truck mounted units with Basic Controls only. If your unit is equipped with computerized controllers, please refer to Operation manual number M-103-02R or later. If your unit incorporates custom features, some of the information contained in this manual may not apply. If you have any questions regarding this manual or your unit, contact your Etnyre dealer or the E. D. Etnyre Service Department at 1-800-995-2116.



CAUTION

Unusually strong electromagnetic interference could cause the electronic controls on this equipment to temporarily malfunction. Test the effect of two way radios and similar equipment while operating in a safe area.

Reporting Safety Defects

If you believe that your vehicle has a defect which could cause a crash, or could cause injury or death, you should immediately inform the National Highway Traffic Safety Administration (NHTSA) in addition to notifying E. D. Etnyre & Co.

If NHTSA receives similar complaints, it may open an investigation; and, if it finds that a safety defect exists in a group of vehicles, it may order a recall and remedy campaign. However, NHTSA cannot become involved in individual problems between you, your dealer, or E. D. Etnyre & Co.

To contact NHTSA, you may either call the Auto Safety Hotline toll free at 1-800-424-9393 (or 336-0123 in the Washington, D.C. area). or write to NHTSA, U.S. Department of Transportation, Washington, DC, 20696. You can also obtain other information about motor vehicle safety from the hotline.

Component Location And Identification

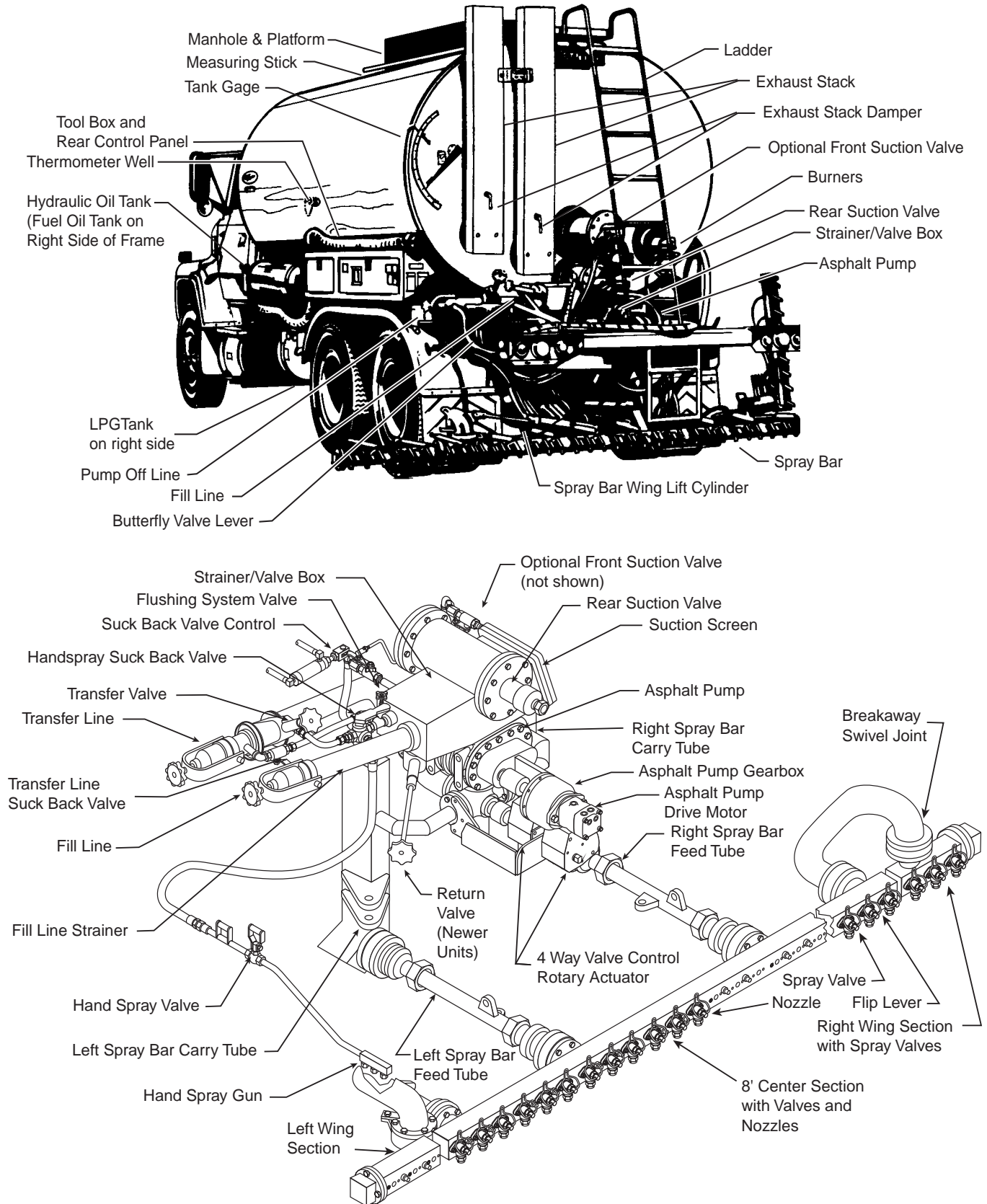

Component Location And Identification

Spray Bar Component Identification

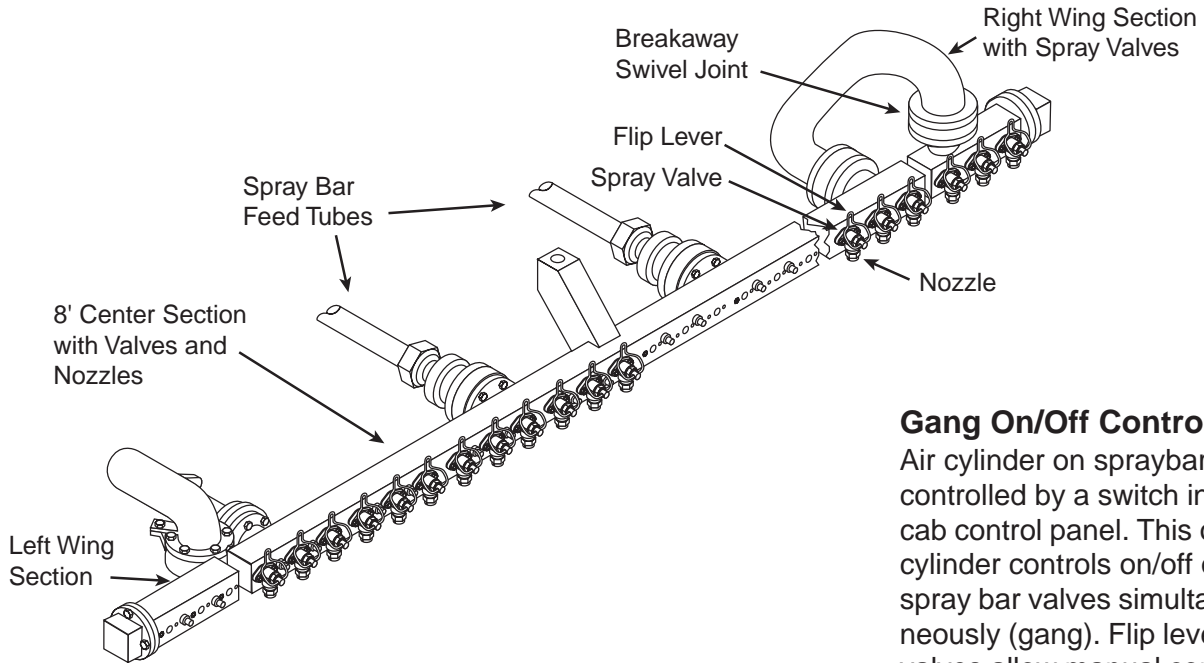

Gang On/Off Controls

Air cylinder on spraybar is controlled by a switch in the cab control panel. This one cylinder controls on/off of all spray bar valves simultaneously (gang). Flip levers on valves allow manual control of individual valves.

Hydraulic Tank and Components

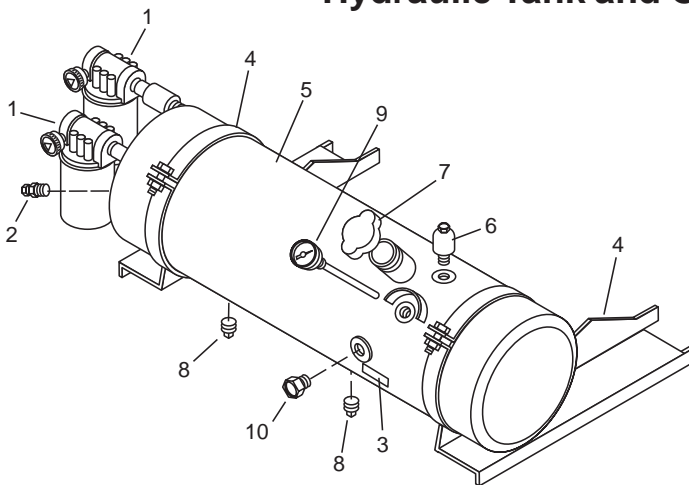

1. Hydraulic Filter
2. Thermo Switch
3. Hydraulic Oil Specifications Instruction Plate
4. Mounting Bracket
5. Hydraulic Tank Assembly
6. Breather
7. Fill Cap
8. Pipe Plug
9. Thermometer
10. Oil Eye Sight Plug

THIS PAGE INTENTIONALLY LEFT BLANK

Component Location And Identification

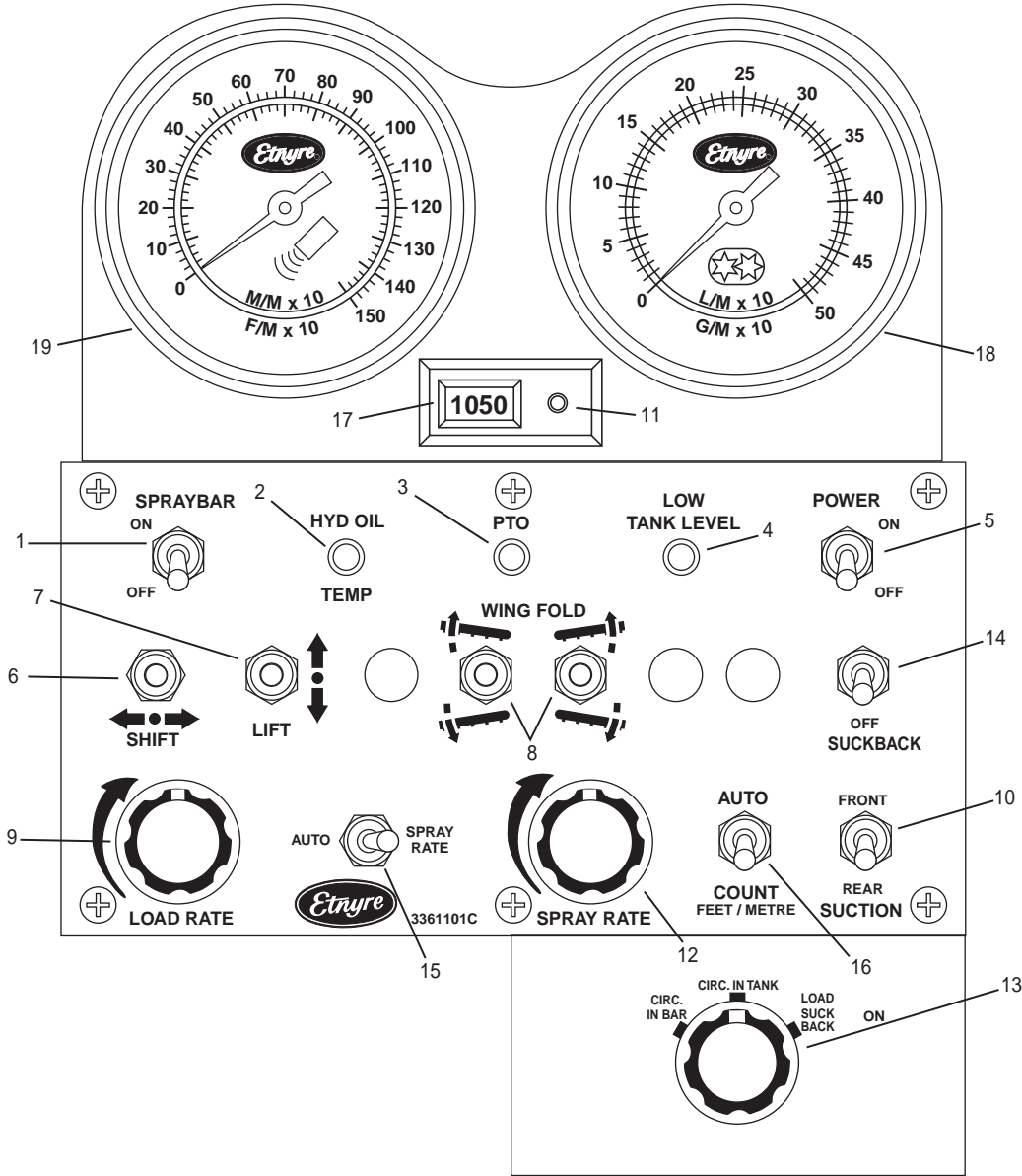

Cab Control panel

See page 12 for description of items

Component Location And Identification

Cab Control Panel

1. Spray Bar Switch

Turns all activated spray bar valves *On* or *Off*.

2. Hydraulic Oil Temperature Warning Light

Indicates that at the hydraulic oil temperature has exceeded 180°F. Stop immediately and determine the cause of the high temperature. Failure to do so will result in damage to hydraulic components.

3. PTO Indicator Light

Indicates PTO engagement for units equipped with a PTO driven hydrostatic pump.

4. Low Tank Level Indicator Light

Indicates low material level in the tank when lit.

5. Power Switch

Controls power to both the front and rear control panels, either *On* or *Off*. Both the front and rear panel power switches must be on to operate the distributor.

6. Bar Shift Switch

Moves the entire Spray Bar *left* or *right*. It is part of the power lift, shift and wing fold option.

7. Bar Lift Switch

This switch *raises* and *lowers* the bar to the lower bar stops and the upper position where it may be latched. It is part of the power lift, shift and wing fold option.

8. Wing Fold Switches

Raise and *lower* the left and right wings. They are also part of the power lift, shift and fold option. It is possible to have three separate folding sections on each wing. If you only have one folding section on a side you will only have one switch per side, and so on.

9. Load Rate Knob

This knob controls the speed of the asphalt pump for all functions requiring circulation or transfer of material except spraying. When spraying (the spray bar

switch is on), the asphalt pump is controlled by the setting of the *Spray Rate Knob*. To increase the circulation or load rate, turn the *Load Rate* knob *clockwise*, and to decrease the circulation rate, turn the *Load Rate* knob *counterclockwise*. In order for this knob to be active, the pump control switch in the rear control box must be on the “Front” position.

10. Suction Switch

This switch is used to select the use of the optional front suction valve instead of the rear suction valve. This switch is also used to close the suction valve.

11. Distance Traveled Reset Button

This button resets the distance traveled count to zero. It can be used after each shot if so desired or at the end of the day's work.

12. Spray Rate Knob

This knob is used to set the *application rate* for spraying. To increase the spray rate, turn the *Spray Rate* knob *clockwise*, and to decrease the spray rate, turn the *Spray Rate* knob *counterclockwise*. In order for this knob to be active, the pump control switch in the rear control box must be on the “Front” position.

13. Rotary Actuator

This knob is for controlling the *4-way valve* and the *suction valve* at the rear of the distributor.

14. Suckback Switch

This switch selects the suckback function. Hold the switch *Up* to activate suckback and release to have normal operation.

15. Auto/Spray Rate Switch

This switch is used to set the spray rate in the spray rate position, using the *Spray Rate knob*. The *Auto* position is used during spraying operations. When this switch is in the *Auto* position, and the *Spray Bar* switch is *Off* (not spraying), the asphalt pump circulation rate is controlled by the setting of the *Load Rate knob*. When spraying is initiated by turning the *Spray Bar* switch *On*, the asphalt pump is automatically switched to correspond with the setting of the *Spray Rate knob*.

Component Location And Identification

16. Auto/Count Switch

This switch determines how the distance traveled is accumulated on the *Distance Traveled Counter*. In the *Auto* position, the distance traveled is accumulated on the *Distance Traveled Counter* only when the *Spray Bar* switch is in the *On* position. In the *Count* position, the distance traveled is continuously accumulated on the *Distance Traveled Counter*.

17. Distance Traveled Counter

The *Distance Traveled Counter* accumulates the feet traveled since the last time it was reset to zero using the *red reset button*. The method in which the distance is accumulated is determined by the position of the *Auto/Count* switch.

18. Pump Rate Gage

Displays the pumping rate in gallons per minute on the outside scale and liters per minute on the inside scale.

19. Vehicle Speed Gage

Displays the vehicle speed in feet per minute on the outside scale and meters per minute on the inside scale.

Component Location And Identification

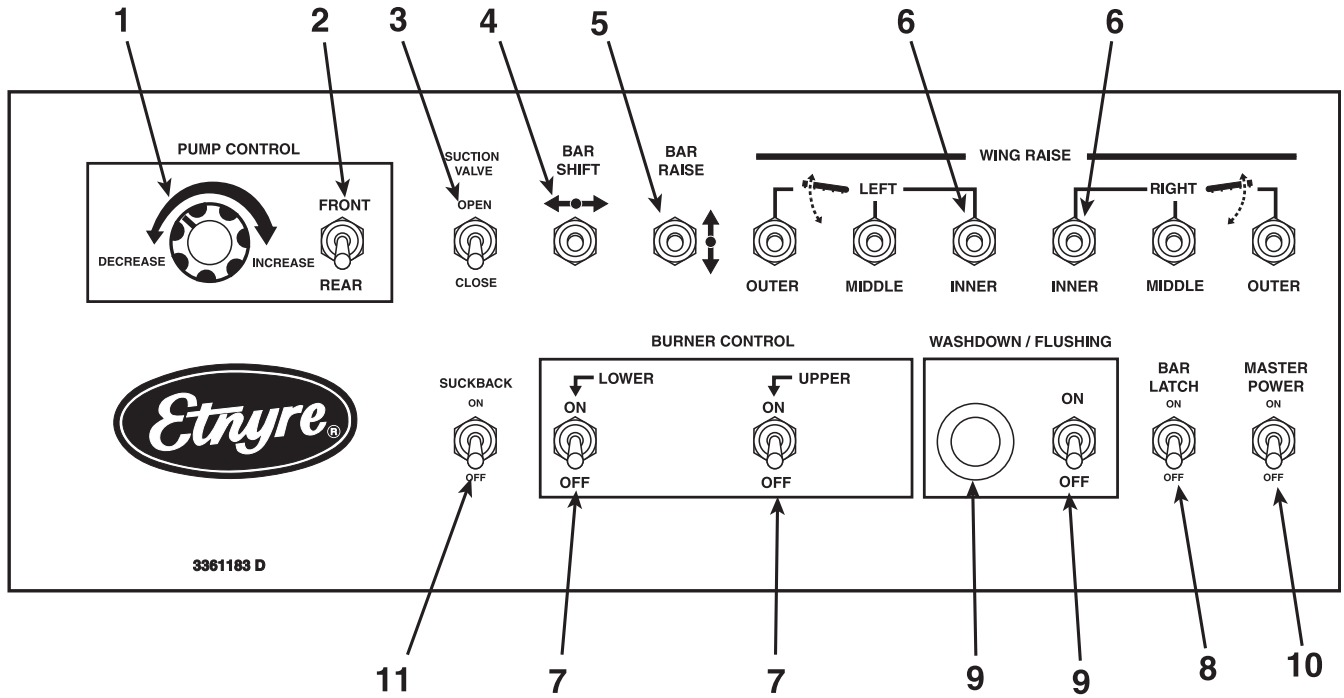

Rear Control panel
 See page 15 for description of items

Component Location And Identification

Rear Control Panel

1. Pump Control Knob

This knob controls the speed of the asphalt pump whenever the pump control switch is in the rear position.

2. Pump Control Switch

This switch selects which pump control is connected to the pump. In the front position, the cab mounted control is active, while in the rear position, the pump control knob adjacent to the switch is connected to the pump. Be sure to select the front position before getting into the cab.

3. Suction Valve Switch

This switch turns the selected suction valve on or off.

4. Bar Shift Switch

This switch moves the spray bar left and right. It is a part of the power lift, shift and raise option. If your Distributor is not equipped with this option, this switch will not be there.

5. Bar Lift Switch

This switch moves the spray bar up to the latch position and down to the spray position. It is a part of the power lift, shift and raise option. If your Distributor is not equipped with this option, this switch will not be there.

6. Wing Fold Switches

These switches raise and lower the right and left spray bar wings. It is possible to have three separate sections on each wing so the panel is set up for that. They are part of the power lift, shift and raise option. If your Distributor is not equipped with this option, these switches will not be there. If you have single folding wing sections, there will only be one switch per side.

7. Burner Power Switches

These switches apply power to drive the burner blowers and start the burners. Before operating the burners, refer to the portion of the manual which explains the burner operation.

8. Bar Latch Switch

This switch operates the power bar latches for travel. This is a separate option. If your Distributor is not equipped with this option, this switch will not be here.

9. Washdown Switch

This switch activates the pump for power washdown. When the pump is turned on, the indicator light and buzzer will be on. This is a separate option. If your Distributor is not equipped with this option, this switch will not be here.

10. Master Power Switch

This switch turns the power to the front and rear control panels on or off. Be sure to turn this switch off at the back of the distributor when you are finished, to guard against movement by untrained personnel. Since all power is disabled by this switch it can also be used as an emergency shutdown switch

11. Suckback Switch

This switch selects the suckback function. Hold the switch *Up* to activate suckback and release to have normal operation. (optional)

Preparing for Operation

Always refer to the truck chassis owner's manual for chassis and engine maintenance information.

The following procedures apply to new or rebuilt units.

1. Inspect the unit for damage that may have occurred during transporting.
2. Check and tighten all fasteners, body tie-down bolts, pipe and circulating line connections, etc. that may have loosened in transit.
3. Check the fluid level in the hydraulic reservoir. The fluid must always be visible in the sight glass and preferably within 3 to 4 inches of the top of the reservoir.

Establishing the Flow Rate/Ground Speed Ratio

The hydrostatic drive consists of a variable displacement pump, driven by the truck PTO or directly off the front of the crankshaft, which in turn, drives a hydraulic motor which is coupled to the asphalt pump through a planetary gearbox. Once the correct ratio between ground speed and pump flow rate is established for a given transmission setting, the truck speed may be varied without affecting the application rate.

Using the Etnyre Computer

1. To determine the proper speed and pump discharge, use the Etnyre Computer. On the top scale, find the spray bar length to be used.
2. At the right end of the Computer, grasp the slide in the thumb recess and move the slide until the de-

sired application rate is directly below the spray bar length.

3. Below the desired speed, you will find the necessary pump discharge rate.

Let's do a sample calculation for 12 feet of spray bar at an application rate of 0.3 gallons per sq yd. and a truck speed of 250 fpm. Move the slide to set the .3 directly under the 12 ft. Now you can see that directly below the 250 fpm distributor speed is the required asphalt pump rate of 100 gpm. The reverse side of the computer presents the information in metric units.

4. Select a transmission gear that will provide 250 fpm at 1200 to 1600 rpm of the truck engine.

WARNING

To prevent severe injury from becoming entangled in machinery: Stand clear of rotating drives

WARNING

To prevent possible burns to operators or bystanders, or possible equipment damage, do not start any operation if any control settings are unknown.

CAUTION

To prevent damage to the asphalt pump, do not run pump for more than 5 minutes without bitumen to supply lubrication

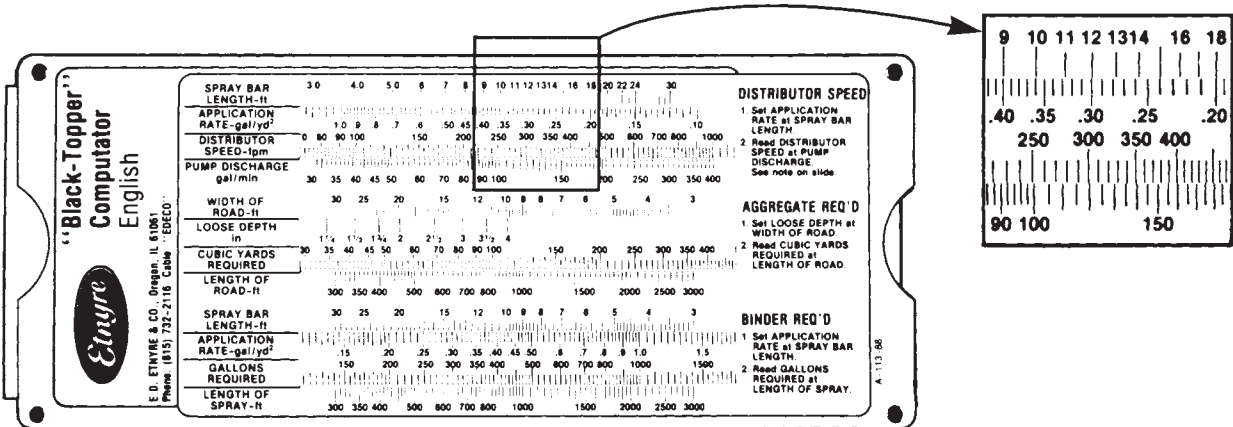

Etnyre Computer

Engaging Pump on PTO Equipped Distributors

Before getting into the cab, check to make sure that the front/rear pump control switch on the rear control panel is in the forward position.

Start the truck engine with the transmission in neutral and engage the PTO. On trucks with a manual transmission, depress the clutch and pull outward or upward on the PTO control knob. Slowly let the clutch up, if the PTO fails to engage, depress the clutch pedal and pull up on the PTO handle until engagement occurs. Or, depress the electric air shift PTO switch if your vehicle is so equipped. Increase the engine rpm to a fast idle.

On trucks with an automatic transmission, push down on the foot brake pedal, move the gear selector to any forward gear and pull upward or outward on the PTO control knob. Or depress the electric air shift PTO switch if your vehicle is so equipped. When the PTO engages, move the gear selector to neutral.

If the PTO fails to engage, continue pulling on the knob while releasing the brake pedal slightly, allowing the truck to inch forward until the PTO engages and then move the gear selector back to neutral.

Ensure that the truck parking brake is engaged before leaving the cab.



WARNING

To prevent an explosion or fire hazard: Do not heat the material beyond the manufacturer's recommended temperature.



CAUTION

To prevent possible damage to equipment from material setting up in hose or distributor, ensure that bitumen in supply tank is heated sufficiently.



WARNING

To prevent possible burns: Use extreme caution when using a torch to heat the pump. Asphalt accumulated around the pump may ignite when heating the pump with a torch.

Foaming

If the distributor is to be filled with hot bitumen, proceed very cautiously. If there is any moisture in the tank, or if an emulsion product was the last load, foaming or eruption may occur.

Dow-Corning DC-200 may be used to prevent foaming in Distributors, Transports, and Maintenance Units.

Mix the contents of one can (16 oz.) with one (1) gallon of diesel fuel or kerosene. Add one (1) oz. of this diluted mixture to each 1000 gallons of asphalt. The correct amount may be poured through the manhole. This will assist in reducing foaming, particularly if moisture is present or if an emulsified asphalt was used in a previous load.

If foaming does not occur at the start of the filling operation, but you suspect that there may be moisture in the spray bar or circulating system, the filling operation should be stopped when the tank is no more than 25% full. The product should then be circulated through the spray bar at a rate of 80 to 100 GPM before continuing the filling operation.

If foaming does occur, continue circulating until the foaming stops, and then suck back the product in the spray bar back into the tank before filling the tank the rest of the way.

Asphalt Institute

To further increase awareness of the hazards associated with the operation of a bituminous distributor, and before beginning initial operation, the operator should also receive instruction by an authorized Etnyre dealer, or Etnyre representative.

The Centennial Distributor is designed to handle a number of different products, such as AC's, cutbacks & emulsions.

Knowledge of these liquid asphalts is required for safe operation of the distributor. It is critical to know which product can be loaded after the previous product, and which products react with each other.

The Asphalt Institute is a source of asphalt handling safety information.

Asphalt Institute
Research Park Drive
PO Box 140052
Lexington, KY 40512-4052
606-288-4960

General

Tank Capacity

The Centennial Distributor is designed to pump and spray a variety of asphalt products in an efficient and user friendly manner with great accuracy. The Centennial Distributor utilizes a computer to sense the vehicle's ground speed and control the hydrostatically driven asphalt pump to maintain the set application rate, regardless of variations in vehicle speed or spray bar width in use.

For a complete description of each of the controls and how to set up the machine, refer to the set up section of this manual.



WARNING

To prevent possible personal injury: Do not load the vehicle beyond the GAWR or GVWR. The maximum load volume must be calculated based on material density

The Centennial Distributor tank has a built-in air space, or expansion space, above the "Tank Full" level. This air space is designed to minimize the chance that the tank will overflow if the material in the tank expands due to heating or foaming. This air space should not be used to carry product. The "Tank Full" level is based on the vehicle's axle ratings, and, GVWR at a material density of 7.7 lbs/gallon. A lower "tank full" must be calculated if a product with a density greater than 7.7 lbs/gallon is to be loaded. The lower "tank full" is calculated by multiplying the original "tank full" by 7.7 and dividing the result by the new heavier product density.

If you suspect there may be moisture or emulsion in the tank, Dow-Corning DC-200 additive can be used to reduce foaming if a product being pumped is at a temperature in excess of 200°F. Additional DC-200 additive may be obtained from E. D. Etnyre & Co. or your Etnyre dealer.

Mixing Dow-Corning DC-200 Anti Foam Agent

Mix the contents of one can (16 oz.) with one (1) gallon of diesel fuel or kerosene. Add one (1) ounce of this diluted mixture to each 1000 gallons of asphalt. The correct amount may be poured through the man-hole. This will assist in reducing foaming, particularly if moisture is present or if an emulsified asphalt was

used in a previous load.

If you suspect that there may be moisture in the spray bar or circulating system, the filling operation should be stopped when the tank is no more than 25% full. The product should then be circulated from the tank through the spray bar for a minimum of 2 minutes at a rate of 80 to 110 GPM before continuing the filling operation. After circulating product in the spray bar, suck back the material from the bar and then return to the loading configuration and continue loading.

If foaming does occur, continue circulating until the foaming stops, and then suck back the product from the spray bar into the tank before continuing the loading operation.

Filling Through the Fill Line



WARNING

To prevent possible burns from foaming or violent eruption, do not load tank with material temperature over 200°F if water or condensation is present in tank, or if emulsion was used in the previous load. Do not heat material over 200°F if moisture or emulsion is present in tank.

Connections and Preliminary Checks



WARNING

To prevent possible burns from leaking material: Be sure all pipe, cap and hose connections are secure before opening valves or beginning any operation.



WARNING

To prevent possible burns to operators or bystanders, or possible equipment damage, do not start any operation if any control settings are unknown.

WARNING

To prevent an explosion or fire hazard: Keep burning cigarettes or other sources of combustion away from manholes and overflow vents.

WARNING

To prevent burns: Always wear eye protection, long sleeve shirt, insulated gloves, boots, and long pants outside the boots when working around the distributor.

Ensure that both the fill line and the suction strainers are clean and properly installed.

Ensure that all connections between the distributor and the supply source are tight to prevent asphalt leaks. Air leaks will reduce the vacuum and slow down the filling operation. The distributor is designed to suck asphalt through the fill line. ***Do not pressurize the fill line with an external pump.***

WARNING

Before removing the fill line cap, make certain that the asphalt pump is turning and the suction valve is closed.

Filling from the Cab

If you have not yet done so, read “Filling through the fill line” before continuing.

1. Set all of the valve positions first. (See Fig 2)
2. Be sure that the master power switch is in the off position to insure that nothing can function while switches are being set.
3. Turn the “Spray Bar” switch “off” to insure that the spray bar valves remain closed when the “Master” switch is turned back on..
4. The optional Front/Rear “Suction” switch can be in either position.
5. Turn the “Rotary Actuator” knob to the “Load/Suckback” position. This positions the 4-way valve in the “Load” position.

At the rear panel:

Place the “Pump Control” switch in the “front” position. This disables the rear panel pump control and makes the front panel pump control active.

Place the “Suction Valve” switch in the closed position. This insures that the pump will not remove any

material from the tank.

Turn the “Master Power” switch “on” to enable the front control panel.

6. At the cab panel, turn the “Power” switch “on”. Both the front and rear power switches must be on to operate.

7. Run the engine at a minimum of 1100 RPM.

WARNING

To prevent possible burns from material overflow: Allow sufficient space in the tank for expansion of the material when heating

8. Rotate the “Load Rate” knob to obtain the desired rate. A pump rate of 75 GPM is recommended to begin the loading operation. The pump rate can be increased at any time after loading has begun by using the load rate knob. Depending on material viscosity, as the loading rate is increased, the asphalt pump may cavitate. When this happens, the pump will make a distinctive sound, easily recognized with experience. Short periods of operation while the pump is cavitating will not damage the pump but you should not operate the pump in this condition for extended periods. Higher speeds will not load thick material faster. Light materials or materials at spraying temperature, may be loaded at faster pump speeds.

Using the Measuring Stick

The measuring stick is only accurate when the tank is level.

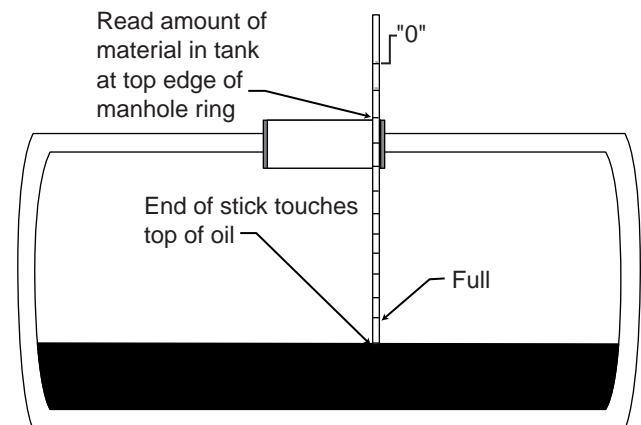

Figure 1 Using the Measuring Stick

WARNING

To prevent an explosion or fire hazard: Keep burning cigarettes or other sources of combustion away from manholes and overflow vents.

9. Open the valve at the supply source and monitor the tank gage. When the gage shows full, close the supply valve.

10. After closing off the supply valve, While the distributor pump is turning, *carefully break the connection between the supply source valve and the hose until you hear a vacuum and elevate the hose to allow maximum drainage to the fill line.*

WARNING

To prevent burns: Always wear insulated gloves when handling spray bar sections or hoses.

11. Allow the pump to continue turning while the hose is disconnected from the fill line and the fill line cap is replaced and secured.

12. Reduce the pump rate to 0 using the load rate knob.

Filling from the Rear Control Panel

1. Set all of the valve positions first.
2. Turn the “Power Switch” “on” at the cab control panel.
3. At the rear control panel, turn the “Pump Control” knob fully counterclockwise to insure the pump is at minimum speed before switching to the rear pump control.
4. Place the “Pump Control” switch to the “rear” position to enable control of the pump from the rear.
5. Place the “Suction Valve” switch in the “Closed” position to prevent sucking material out of the tank.
6. Turn the “Master Power” switch “On”.
7. Adjust the “Pump Control” knob to get the desired rate.

A pump rate of 75 GPM is recommended to begin the loading operation. The pump rate can be increased at any time after loading has begun by using pump control knob. Depending on material viscosity, as the loading rate is increased, the asphalt pump may cavitate. When this happens, the pump will make a distinctive sound, easily recognized with experience. Short periods of operation while the pump is cavitating will not damage the pump but you should not operate the pump in this condition for extended periods.

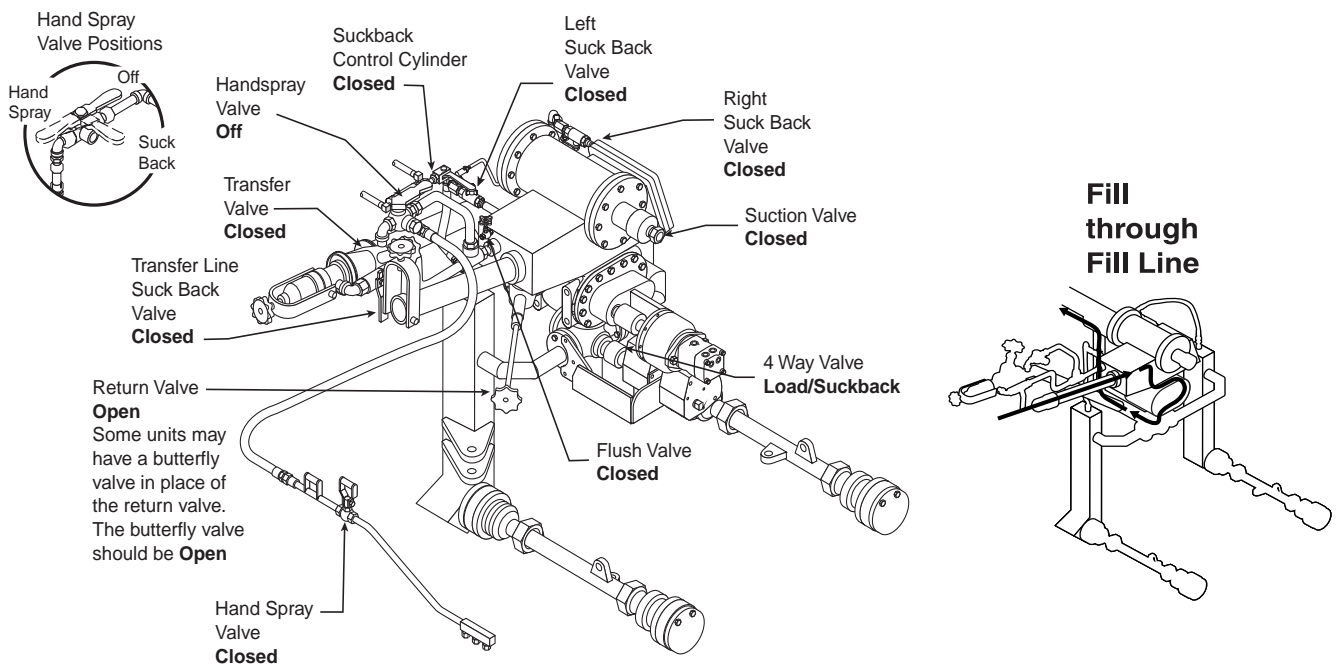

Figure 2. Valve Positions for Filling Through the Fill Line

! WARNING

To prevent possible burns from material overflow: Allow sufficient space in the tank for expansion of the material when heating

Higher pump speeds will not load thicker materials faster. Lighter materials, or heavy materials which are already at spraying temperature, may be loaded at faster rates.

! WARNING

To prevent an explosion or fire hazard: Keep burning cigarettes or other sources of combustion away from manholes and overflow vents.

8. Open the valve at the supply source and monitor the tank gauge. When the gauge shows full, Close the supply valve

9. After closing the supply tank valve, while the asphalt pump is still turning, **carefully break the connection between the supply source valve and the hose until you hear a vacuum and elevate the hose to allow maximum drainage to the fill line.**

10. Disconnect the hose at the supply end and elevate the hose to allow maximum drainage of the product into the fill line.

! WARNING

To prevent burns: Always wear insulated gloves when handling spray bar sections or hoses.

11. Allow the pump to continue turning while the hose is disconnected from the fill line and the fill line cap is replaced and tightened.

Filling through the Manhole

Be sure that the suction valve switch is in the closed position before starting to fill the distributor through the manhole.

Set all of the valve positions first.

To reduce the risk of accidental discharge of asphalt, the asphalt pump should not be running when filling through the manhole. When the gage shows full, close the supply valve

! WARNING

To prevent possible injury: Always open the manhole cover slowly. Pressure build up in the tank may cause the cover to burst open.

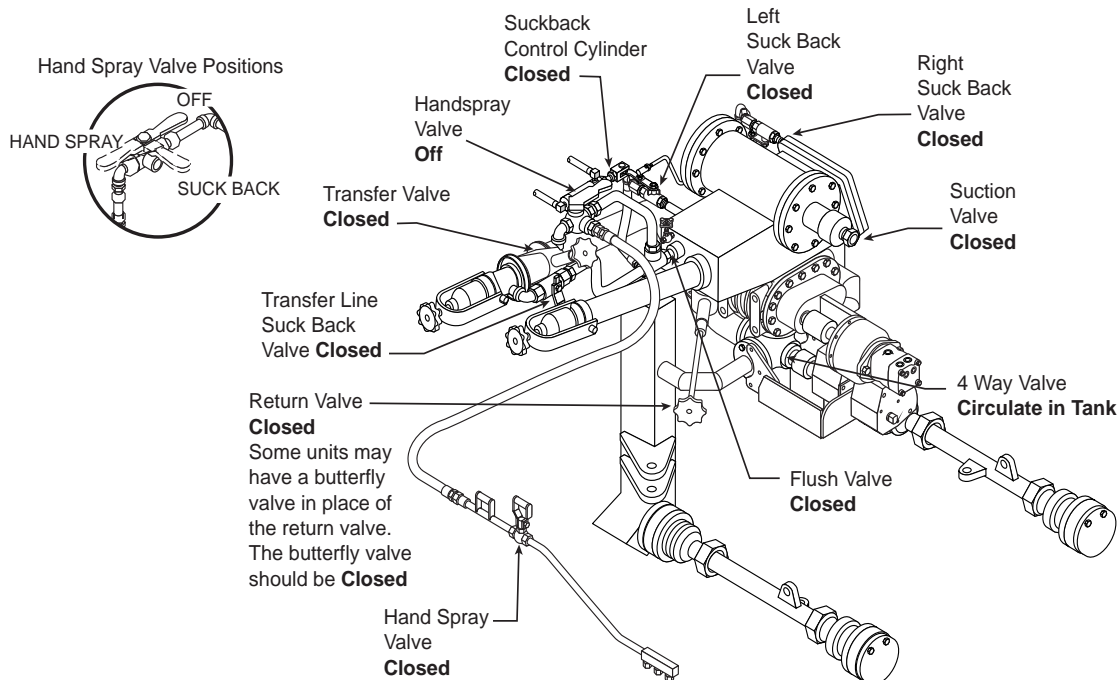

Figure 3. Valve Positions for Filling Through the Manhole

Circulating Product in the Tank

| |
|--|
|  WARNING |
| <p>To prevent an explosion or fire hazard: Keep burning cigarettes or other sources of combustion away from manholes and overflow vents.</p> |

Circulating in the tank from the cab

Set all of the valve positions first.

In the cab

Be sure that the “Power” switch is in the “Off” position to insure that nothing can function while switches are being set.

Turn the “Spray Bar” switch “Off” to insure that the spray bar valves remain closed when the master power switch is turned back on.

Turn the “Rotary Actuator” to the “Circulate in Tank” position to position the 4-way valve in the circulate in tank position.

The optional “Front/Rear Suction” switch can be in either position.

At the rear control panel.

a. Place the “Pump Control switch in the front position to supply power to the cab pump control.

b. Place the “Suction Valve” switch in the “Open” position to open the suction valve.

c. Turn the “Master Power” switch “On”.

At the cab control panel, turn the “Power” switch “on”

| |
|--|
|  WARNING |
| <p>To prevent possible burns from material overflow: Allow sufficient space in the tank for expansion of the material when heating</p> |

Rotate the “Load Rate” knob to obtain a rate of 100 to 150 GPM which is the recommended rate for heating operations.

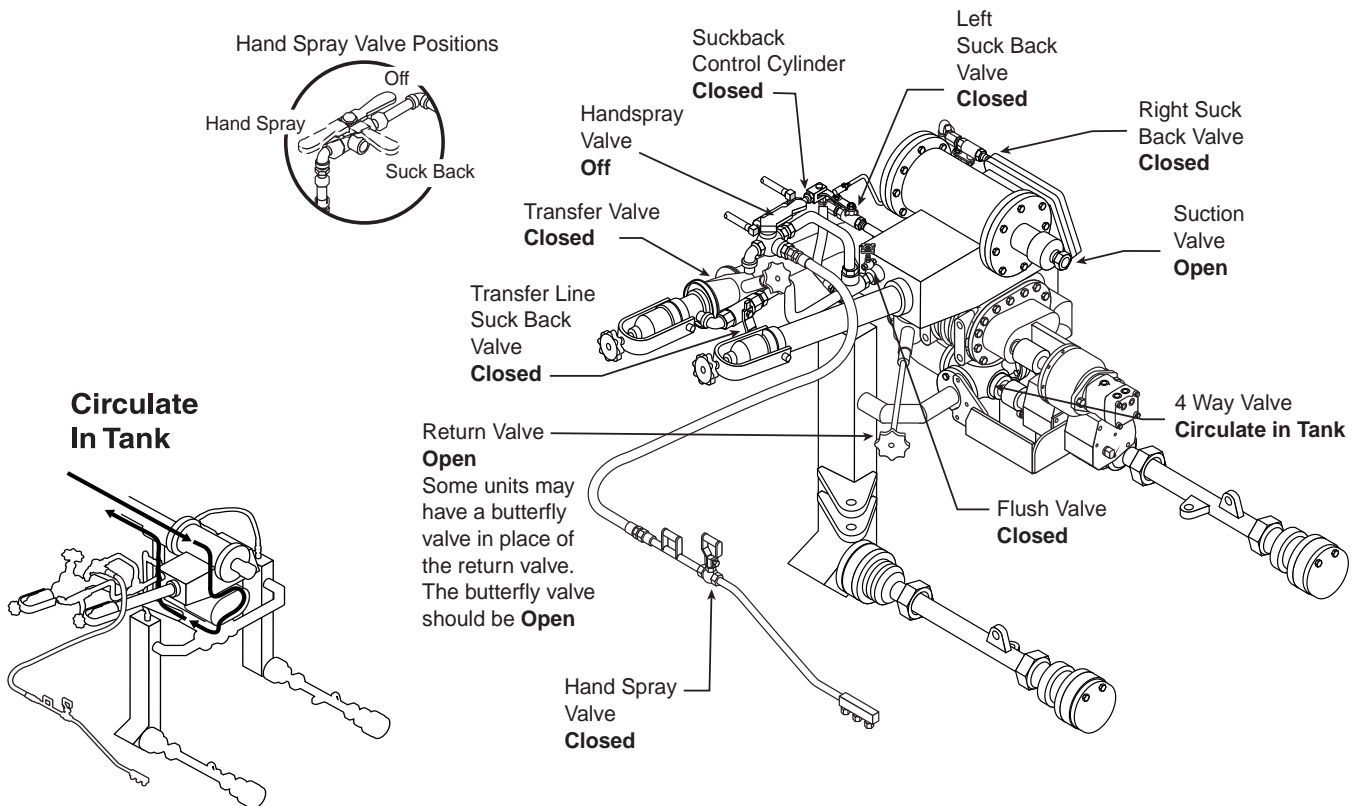

Figure 4 Valve Positions for Circulating in the Tank

Circulating in the Tank from the Rear Control Panel

Before going to the cab to turn the Master Power switch on, be sure that the Power switch in the rear panel is “Off”.

In the cab turn the “Power Switch” to the “On” position.

Turn the “Rotary Actuator” knob to the “Circulate in Tank” position.

At the rear control panel, turn the “Pump Control” knob fully counterclockwise, place the “Pump Control” switch in the “Rear” position.

Turn the “Master Power” switch “On”.

Place the “Suction Valve” in the “Open” position.

Adjust the “Pump Control” to obtain the desired rate. 100 to 150 GPM is recommended for heating operations.

WARNING

To prevent possible burns: Use extreme caution when using a torch to heat the pump. Asphalt accumulated around the pump may ignite when heating the pump with a torch

If the product is too cold to be circulated, some heating with the burners will be needed to increase the temperature enough to be able to start circulating. Refer to the portion of this operating manual for instructions on your particular type of burner.

WARNING

To prevent an explosion or fire hazard: When the burners go out, shut off the fuel supply to both burners and allow the flues to ventilate for at least 3 minutes before re-lighting the burners

WARNING

To prevent an explosion: Do not operate the burners when the vehicle is unattended, when the vehicle is in motion, or with the vehicle in a confined area

Hand Spray Valve Positions

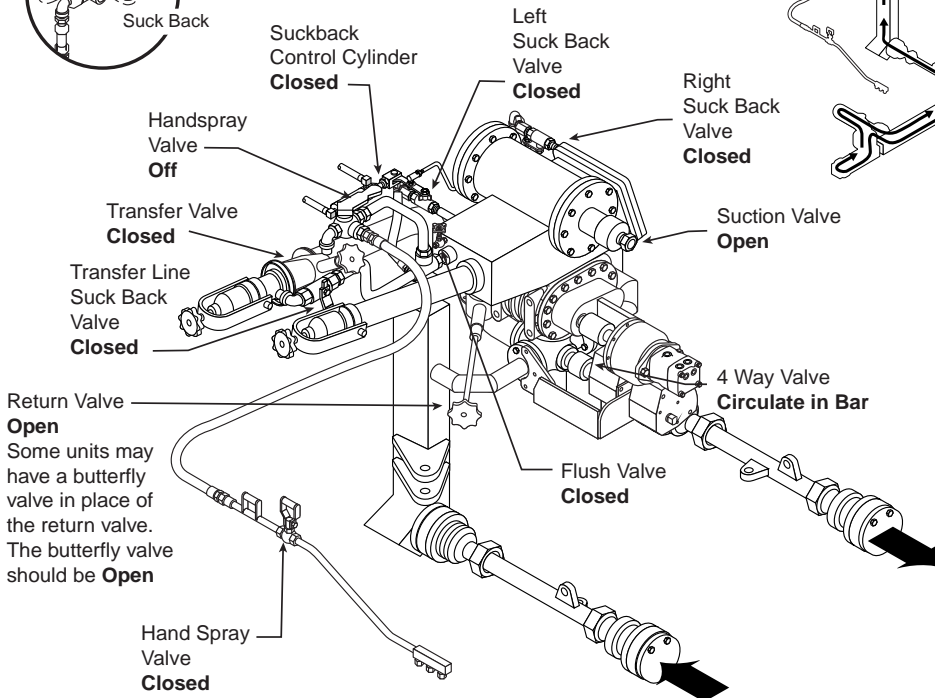
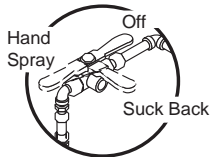

Figure 5. Valve Positions for Circulating in the Bar

Circulating Product in the Bar

WARNING

To prevent an explosion or fire hazard: Ensure that the burners are extinguished before removing any material from the tank in any manner. Liquid petroleum (LP) burners can support a flame for several minutes after the fuel supply is turned off.

1. Set all of the valve positions first.

Perform the procedure for circulating in the tank first. Then move the rotary actuator knob to the “Circulate in Bar” position. The circulate in bar procedure can be performed from either the cab or the rear control panel.

CAUTION

To prevent excessive pressure in the spray bar, the asphalt pump speed should not exceed 160 GPM while circulating in the spray bar.

Circulate product long enough to ensure removal of all air from the bar and to heat the spray bar valves sufficiently. For better material circulation, in the bar ends, the wings should be extended.

Spraying Operations

A correct spray pattern cannot be obtained unless the product is heated to its proper spraying temperature. Cold product will not provide sharp spray edges, and will cause streaking. If heating of the product is required, refer to the section of this manual on “Heating Product in Distributors” or your Operator’s Manual for instruction on operation of your particular type of burners.

The circulation rate in the bar when not spraying should be set to 50% of the pump speed while spraying. This circulation rate will allow the asphalt pump to reach the desired speed quickly when spraying is started. Circulation rates higher than 50% will result in a heavier start while rates below 50% will produce a lighter start.

WARNING

To prevent an explosion or fire hazard: Ensure that the burners are extinguished before removing any material from the tank in any manner. Liquid petroleum (LP) burners can support a flame for several minutes after the fuel supply is turned off.

To prevent an explosion: Do not operate the burners when the vehicle is unattended, when the vehicle is in motion, or with the vehicle in a confined area.

To prevent an explosion or fire hazard: When the burners go out, shut off the fuel supply to both burners and allow the flues to ventilate for at least 3 minutes before re-lighting the burners.

To prevent an explosion or fire hazard: Do not heat the material beyond the manufacturer’s recommended temperature.

To prevent an explosion or fire hazard: Keep burning cigarettes or other sources of combustion away from manholes and overflow vents.

To prevent possible hand or facial burns: Always light the inside burner first. Do not reach across a lit burner to light or re-light the inside burner. Shut off the outside burner before lighting the inside burner.

To prevent possible burns from material overflow: Allow sufficient space in the tank for expansion of the material when heating

To prevent possible burns to operators or bystanders, or possible equipment damage, do not start any operation if any control settings are unknown.

To prevent possible burns from leaking material: Be sure all pipe, cap and hose connections are secure before opening valves.

WARNING

To prevent possible burns from hot asphalt spray: Do not stand, or allow anyone to stand, where accidental opening of a valve may cause contact with hot asphalt.

Spray bar nozzles have a limited flow range at which optimal performance will be achieved. Flow rates greater than this optimal range will cause excessive fogging. Rates that are too low will cause the fan to sag and cause heavy edges. Refer to the nozzle selection chart in the operator's manual to select the nozzles appropriate for your conditions.

Adjusting the Spray Bar Nozzle Angle

Adjust the nozzles to obtain an angle of approximately 30 degrees with the spraybar centerline. Every nozzle should be at the same angle. A nozzle adjustment wrench is supplied with each new unit.

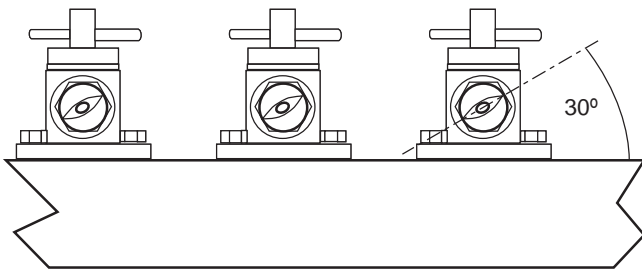

Figure 6. Adjusting the Spray Bar Nozzles

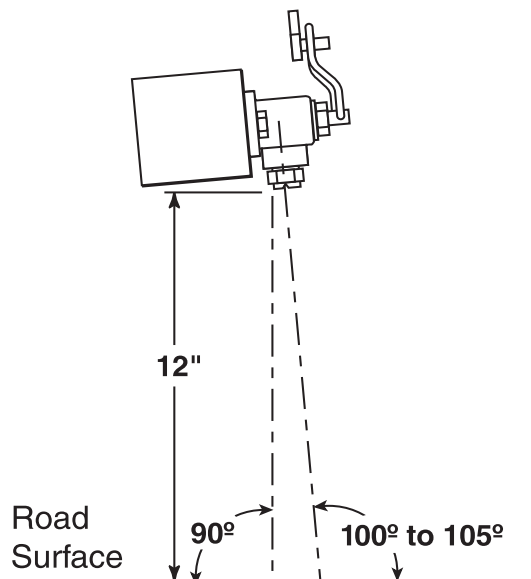

Figure 7. Adjusting the Spray Bar Height.

Adjusting the Spray Bar Height

Lower the spraybar and adjust the down stops so that the nozzles are approximately 12" above the road, on the main bar with both wings folded, when the tank is empty. At this height, the spray fans from the nozzles will overlap to provide triple lap coverage of material on the ground. This is the normal spraying height. Lower the wings and adjust them with the cylinder nuts to follow the crown of the road. The spray bar should be at an angle of 100 to 105 degrees with the surface of the road when viewed across the road. This slight rearward trajectory compensates for the forward movement of the distributor to evenly coat the front and back sides of projections on the road surface.

Spraying through the Bar

Before spraying, place the valves in position for spraying.

At the Rear Panel

- Put the "Pump Control" switch in the "Front" position.
- Put the "Suction Valve" in the "open" position.
- Turn the "Master Power" switch "on".

Adjust the spray bar valves to the desired width, using the flip levers on each nozzle valve. Disengage the flip lever from the buss bar pin to deactivate the nozzle.

In the Cab

Turn the "Master Power" switch "On".

Engage the PTO if the distributor has a PTO driven hydrostatic pump. Before moving the bar, circulate some hot material through the bar. This allows the bar to warm up and also extends the life of the bar seals and o-rings.

Prior to setting the "Rotary Actuator" to the "Circulate in Bar" position, decrease the asphalt pump flow rate to a maximum of 160 GPM, to avoid excessive pressure in the spray bar when you are not spraying. The circulation rate in the bar when not spraying, should be set to 50% of the spray rate, but not greater than 160 gpm. When the desired application rate is set in the computer, place the "Rotary Actuator" in the "Circulate in Bar" position and allow the material to circulate in the bar for a few minutes to warm up the bar, valves and nozzles. Lower the spray bar and continue to heat to bring the spray bar up to operating temperature.

Put the truck transmission and rear axle in the proper settings for the shot.

Start the distributor moving in the pre selected gear.

At the start line of the shot, move the "Spray Bar"

switch to the “On” position. While the distributor is spraying, the truck speed does not have to remain constant to maintain the application rate accuracy, as long as you do not shift gears. At higher speeds, flow rates can increase beyond the nozzle flow rating. When this occurs, fogging will result and you should slow down. At lower speeds, the flow rate may decrease below the recommended nozzle flow rating. When this occurs, the fan droops causing incomplete overlapping, heavy edges and streaking.

When the end of the shot is reached, turn the “Spray Bar” switch “off” or down. The 4-way valve is automatically returned to the “Circulate in Bar” position when the spray bar is turned off.

During the periods between shots, material should be circulated in the spray bar to keep the bar warm and prevent material set up in the bar. However, material should not be circulated in the bar when travelling from location to location. If you want to shut the distributor down at the end of the day or between shots, you must suck back the system. Refer to the suck back portion of this manual for instructions.

CAUTION
Do not run the pump above rated capacity of 400 GPM. Damage to equipment may occur.

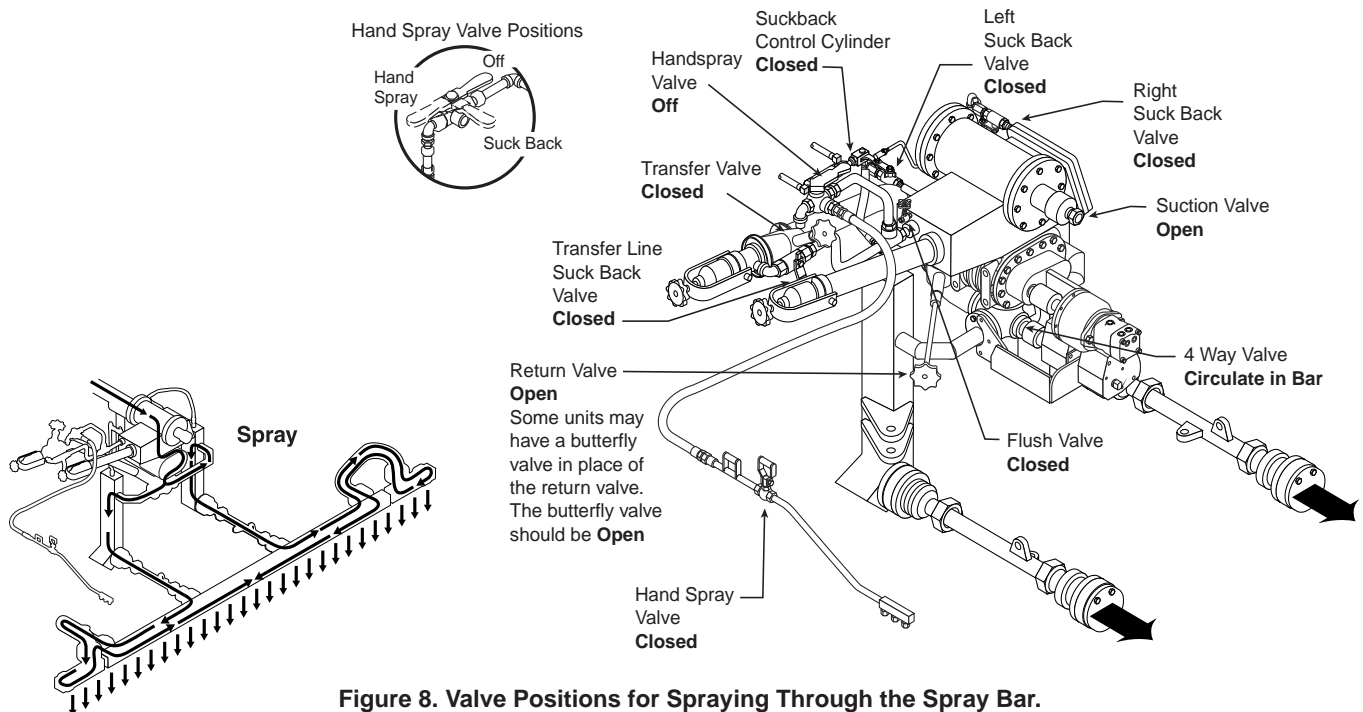

Figure 8. Valve Positions for Spraying Through the Spray Bar.

Suckback from the Cab

Set all of the valve positions first.

Raise the spray bar and fold the wings up.

Turn the “Rotary Actuator” knob to the “Load/Suck-back” position.

Run the pump at 200 gpm using the load rate knob in the cab or set the pump control to “rear” and adjust the pump speed with the rear pump control knob. Remember the gpm reading is displayed only in the cab.

⚠ WARNING

To prevent possible burns from hot asphalt spray: Do not stand, or allow anyone to stand, where accidental opening of a valve may cause contact with hot asphalt.

After sucking back for approximately 2 minutes, open the end valves on the spray bar momentarily to let air into the system. You must hear a positive indication of vacuum for proper suckback.

Close the suckback valves.

Reduce the asphalt pump speed to 100 gpm.

Open the self-flush valve located on the strainer box. This will allow diesel fuel to enter the system and wash out the pump.

After 2 minutes, shut the self-flush valve.

Turn the “Master Power” switch off.

If the unit is equipped with auto wash option, turn the electric pump on with the flush valve open and asphalt pump turned off and run for 2 minutes. This will place a quart of diesel fuel on top of the asphalt pump for better starts after long periods of shutdown.

If not equipped with the electric pump, it is helpful to pour some diesel fuel down the fill line after all operations are completed. The diesel fuel will remain in the pump overnight to keep the pump free for the next morning’s operation.

Ensure that the self flush valve is closed at the end of this function, or before loading or circulating asphalt to eliminate chances of inducing asphalt into the self flush fuel tank.

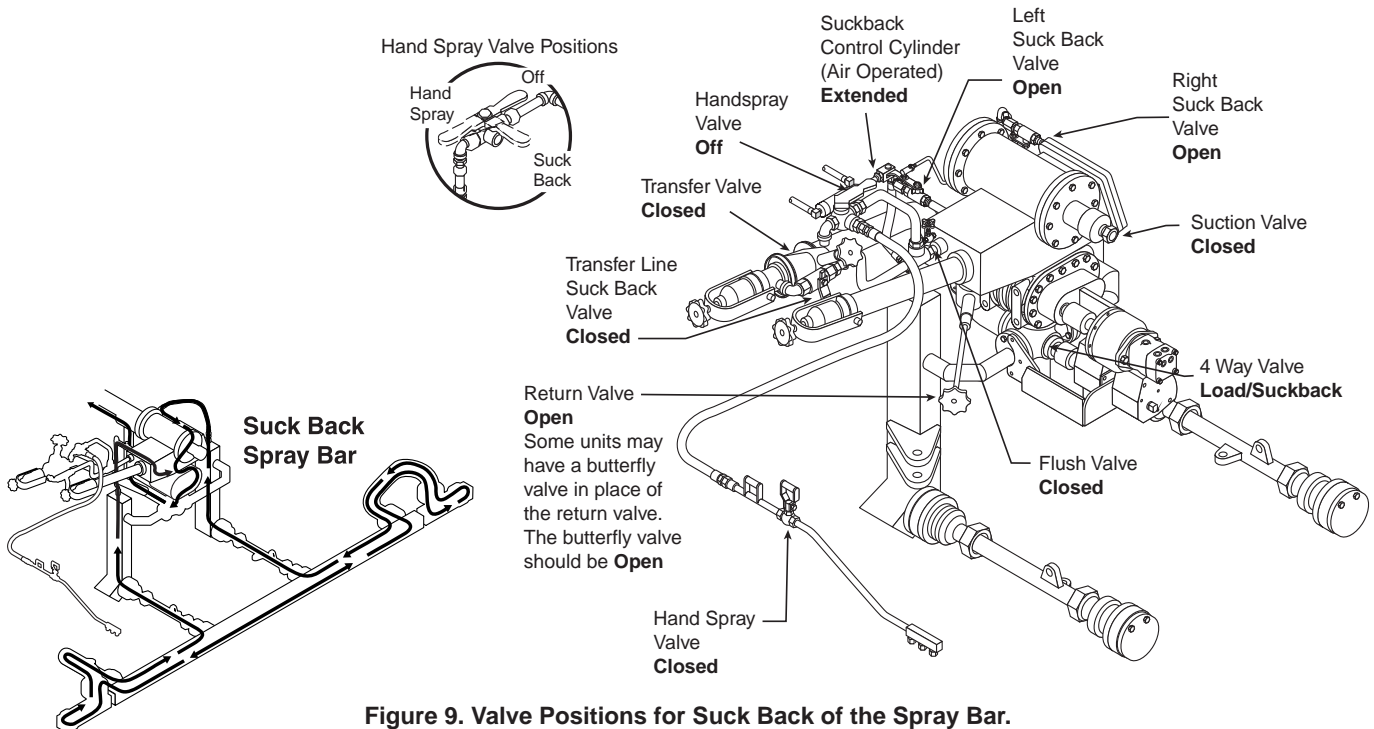

Figure 9. Valve Positions for Suck Back of the Spray Bar.

Handspraying

Before spraying, place the valves in position for handspray.

| |
|--|
| ⚠ WARNING |
| To prevent burns from hot asphalt when handspraying: Hold the handspray gun in proper position and watch for other people. |

| |
|---|
| ⚠ WARNING |
| To prevent burns: Always wear eye protection, long sleeve shirt, insulated gloves, boots, and long pants outside the boots when working around the distributor. |

Adjust the asphalt pump speed to 80 GPM using the “Load Rate” knob in the cab, or set the “Pump Control” switch to “rear” and adjust the pump speed with the “Pump Control” knob. Remember, the GPM reading is only available in the cab of the distributor.

| |
|---|
| ⚠ CAUTION |
| When using rear pump control, engine RPM changes will affect asphalt pump speed |

Turn the handspray valve on the spray wand 90 degrees to spray.

Adjust the handspray pressure with the “Return” valve. Turn the “Return” valve clockwise to increase the handspray pressure. Do not close the “Return” valve completely as this will cause the asphalt to dead head into the handspray hose when the handspray wand is shut off.

If the “Return” valve is approaching the completely closed position and pressure in the wand is insufficient, turn the “Return” valve counter clockwise and increase the asphalt pump flow rate.

When finished hand spraying suck back the handspray system.

At the rear panel, turn the master power switch off.

In the cab

Turn the “Rotary Actuator” knob to the “Circulate in Tank” position.

Turn the spray bar switch “off”.

Turn the “Power” switch “On”.

At the rear panel, turn the Master Power switch on and place the “Suction Valve” switch in the “Open” position.

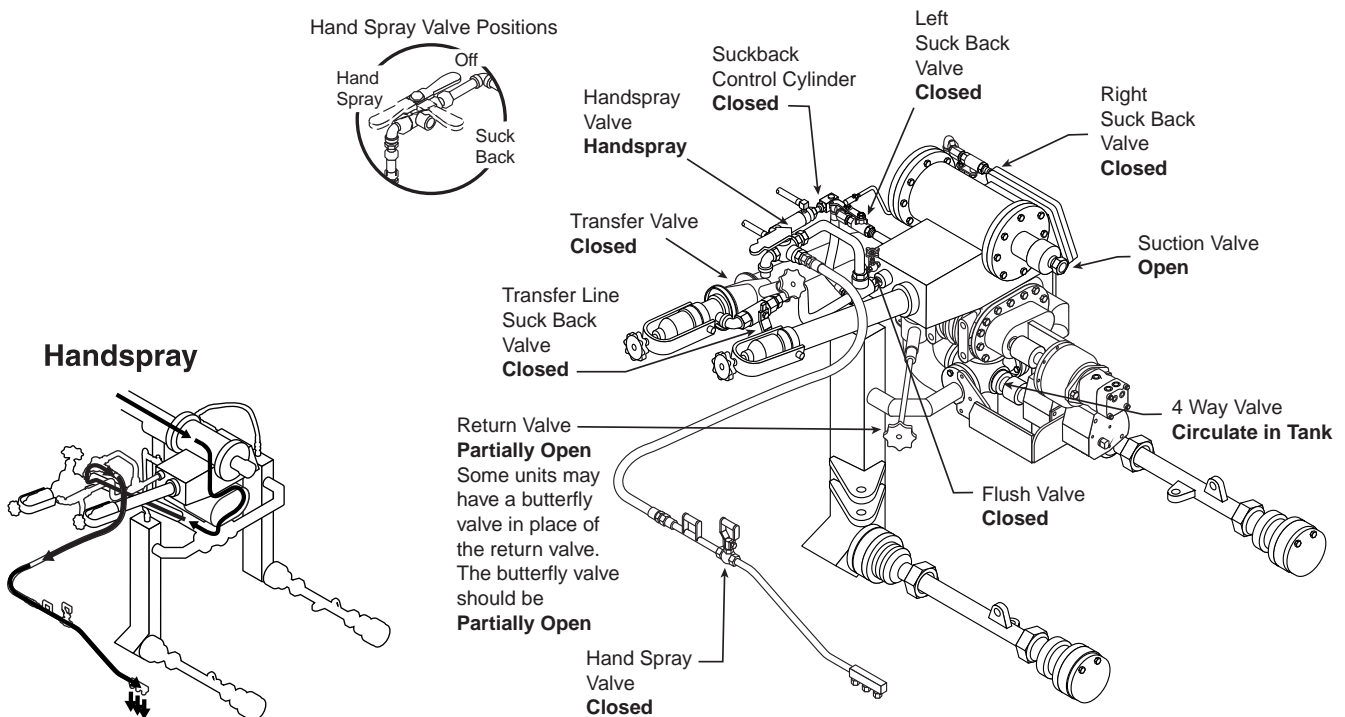

Figure 10. Valve Positions for Handspray.

Suck Back for Hand Spray Operations

When finished hand spraying, set all valves and levers to their positions for handspray suck back.

Turn the “Rotary Actuator” to the “Load/Suckback” position.

Suck back the asphalt from the handspray hose by turning the “Return” valve counter clockwise to the “Open” position.

Open the handspray suckback valve.

Increase the pump speed to approximately 200 GPM.

After approximately 1 minute, crack the handspray valve on the handspray wand “open”. Suck the handspray wand back for about 2 minutes. If finished hand-spraying for the day, crack open the handspray valve with the nozzles submerged in flushing oil. Close the handspray wand valve and shut off the pump.

Return all of the valves to their normal positions.

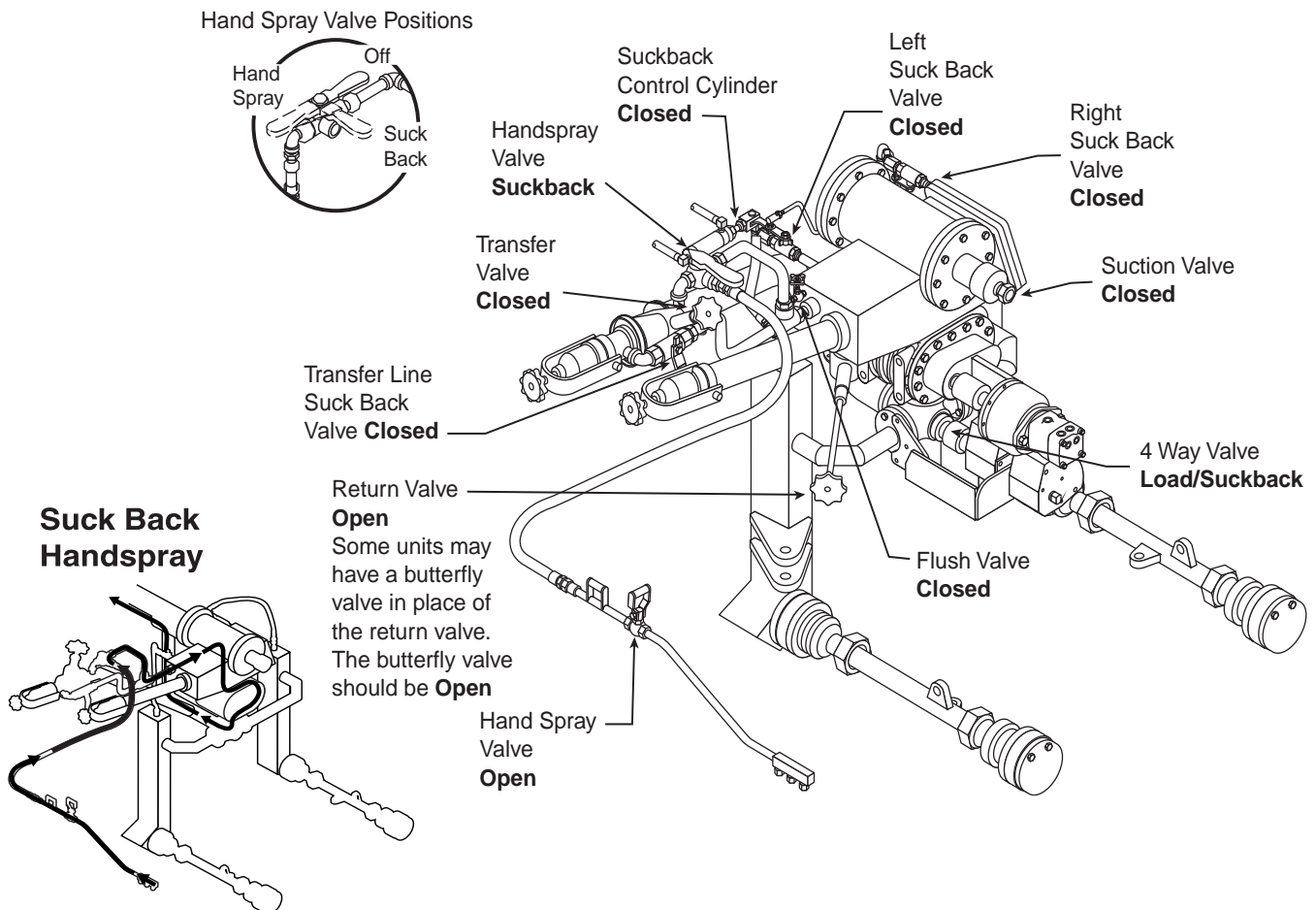

Figure 11. Valve Positions for Handspray Suckback

Pump Off Operations

Connect the pump-off hose from the storage tank to the transfer line.

When preparing to pump off, ensure that all valves in the pump-off line between the distributor and the storage tank are open before opening the suction valve on the distributor.

Set all of the valves and levers to their proper positions for pump-off.

Place the “Rotary Actuator” knob in the “Circulate in Tank” position.

Open the “Transfer” gate valve.

Open the “Suction” valve.

Increase the pump speed to approximately 150 GPM using the “Load Rate” knob in the cab, or set the “Pump Control” switch in the rear control box to “Rear” and adjust the pump speed with the “Pump Control” knob. Remember that the GPM reading is only available in the cab.

Turn the “Return” valve clockwise to the “Closed” position, watch that the pump off hose does not become plugged.

If this happens open the “Return” valve by turning the handwheel counter clockwise.

When pump-off is complete, turn the “Return” valve to the “Open” position.

Close the transfer valve.

Decrease the pump speed to approximately 50 GPM.

Close the “Suction” valve.

Close the valve at the storage tank.

Open the suckback valve in the transfer line, and carefully break the connection at the storage tank, between the storage tank valve and the fill hose to allow air into the hose.

| |
|--|
|  WARNING |
| <p>To prevent burns: Always wear insulated gloves when handling spray bar sections or hoses.</p> |

Increase the pump speed to approximately 150 GPM for 2 minutes.

Increase the pump speed to 200 GPM. Carefully and slowly disconnect the hose at the storage tank end and elevate the hose to allow the maximum drainage of asphalt to the transfer line. Allow the pump to continue turning while the hose is carefully disconnected from the transfer line and the transfer line cap is replaced and secured.

Then shut the pump down and return the suckback valve to its normal position.

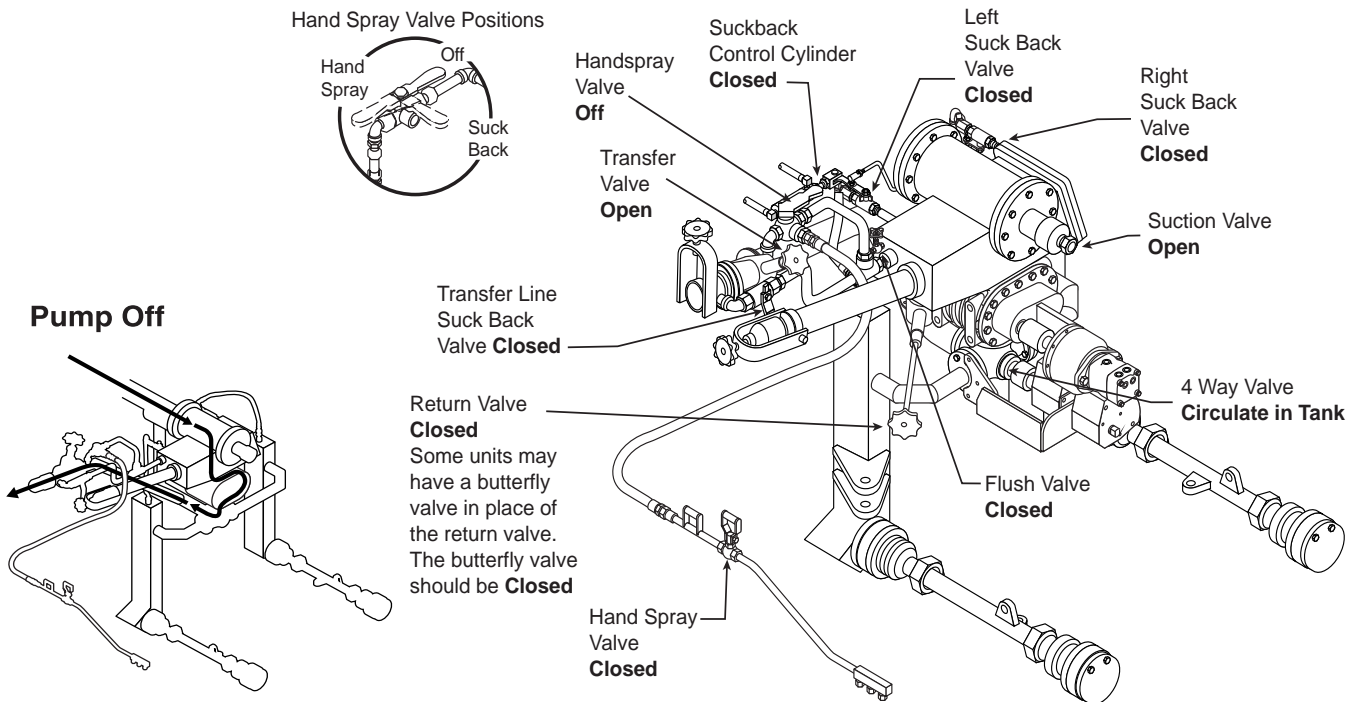

Figure 12. Valve Positions for Pump Off

Transfer Operations

Set all of the valves and levers to their proper positions for transfer.

Close the Suction valve with the switch at the rear panel.

Connect the loading hose from the supply tank to the fill connection. Be sure that the connections are tight.

Connect the transfer hose from the transfer connection to the storage tank. Be sure that the connections are tight.

When preparing to transfer, be sure that all of the valves in the pump off line between the distributor and the storage tank are open before opening the valve on the storage tank containing liquid.

Open the Transfer valve.

Turn the "Return" valve handwheel fully clockwise to the "Closed" position.

Turn the "Rotary Actuator" to the "Load/Suckback" position.

Open the valve at the storage tank.

Slowly and carefully open the valve at the supply source.

Start the pump and increase the pump speed to approximately 150 GPM using the "Load Rate" knob in the cab or set the "Pump Control" switch at the rear control panel to "Rear" and adjust the pump speed using the "Pump Control" knob in the rear control panel.

When finished, close the valve at the supply tank.

Drain the loading hose from the supply tank to the fill connection.

WARNING

To prevent burns: Always wear insulated gloves when handling spray bar sections or hoses

Reduce the pump speed to 50GPM.

Close the valve at the storage tank.

Turn the "Return" valve handwheel fully counter clockwise to the "Open" position.

Close the transfer valve.

Shut off the pump.

Slowly and carefully break the connection at the storage tank and drain the line into a container.

Slowly and carefully break the connection the transfer line and drain the hose into a container.

Replace the caps on the fill and transfer lines.

WARNING

Suckback of the storage tank line will put material into the tank and could cause an explosion if the tank has not been fully cleaned of emulsion material

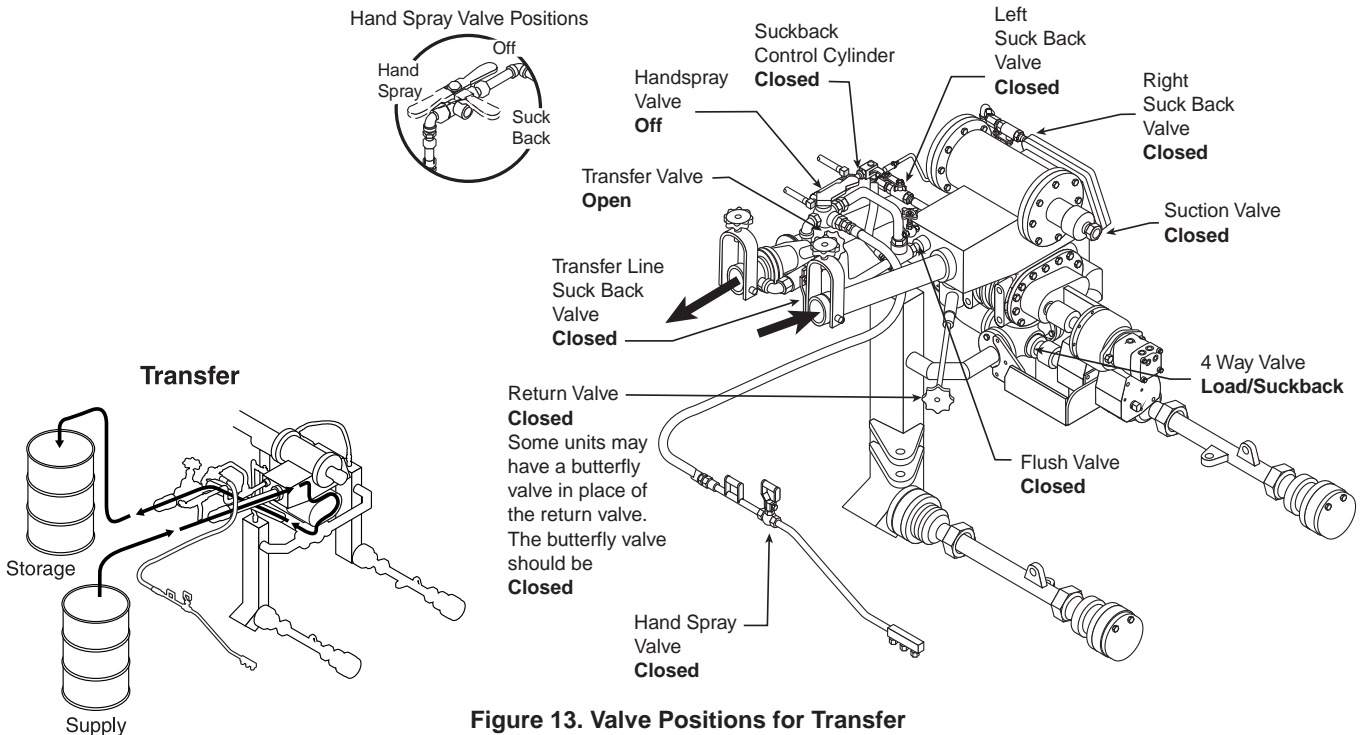

Figure 13. Valve Positions for Transfer

Flushing Operations

Set all of the valves and levers to their proper positions for flushing.

Turn the “Rotary Actuator” to the “Load/Suckback” position.

Ensure that the suction valve is closed.

Open the self-flushing valve and run the pump at approximately 100 GPM.

After 2 minutes, close the self flush valve.

Normally the suckback procedure will remove sufficient material from the circulating system to negate the need for draining the circulating system and spray bar before proceeding with the wash out operation. The flushing operation requires only 3 quarts of flushing solvent. This small amount is not sufficient to fill the lines to the tank, thus preventing solvent from being forced into the tank.

A common practice following completion of the flushing procedure and subsequent shutdown is to pour 1 to 2 quarts of solvent into the fill line. This softens or dissolves the residual asphalt in the pump. Allow these solvents to remain in the system until the next use.

If unit has electric washdown option, open flush valve and turn on electric pump for 2 minutes. This will pump 2 quarts of diesel fuel on top of the asphalt pump.

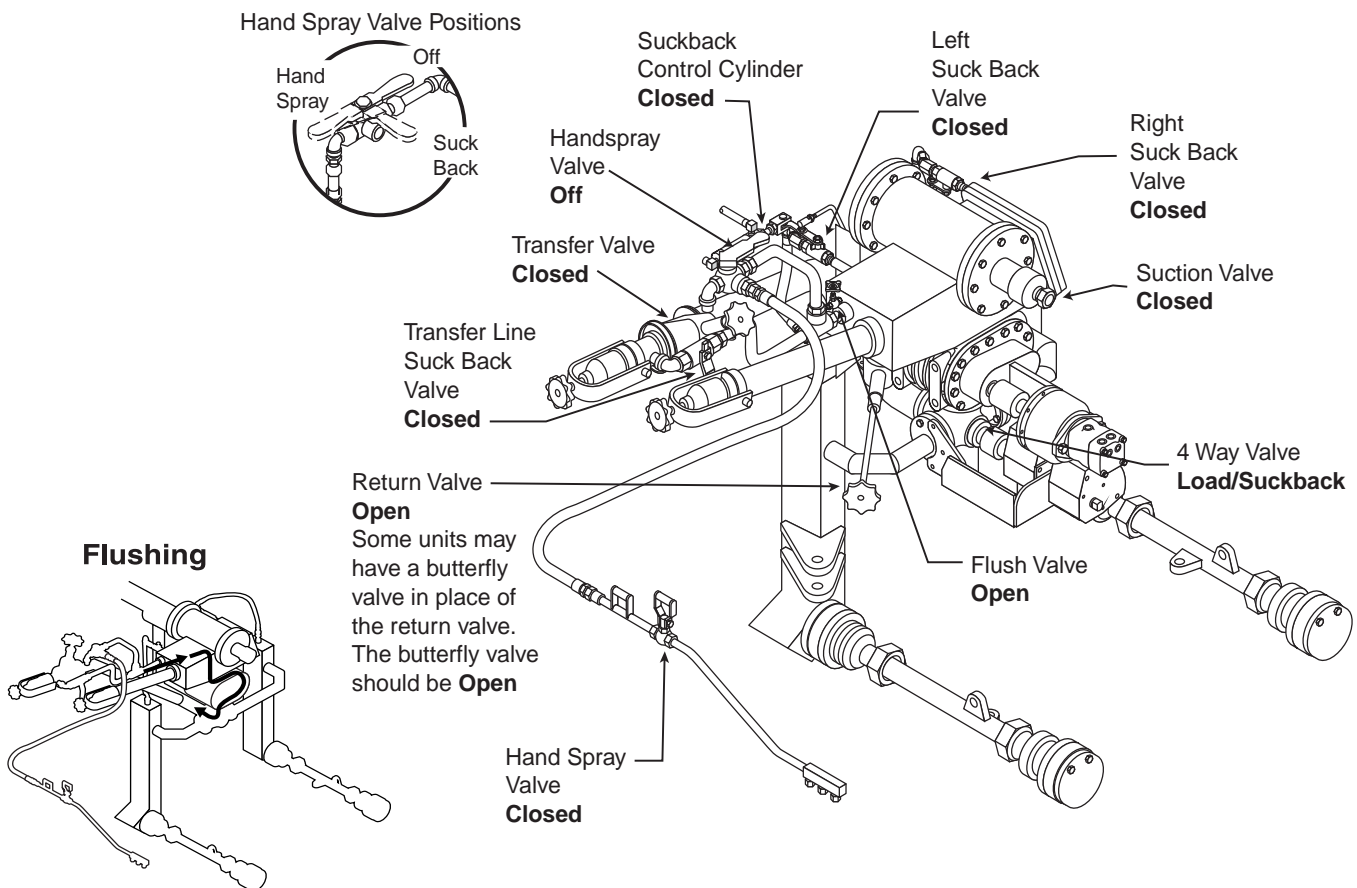

Figure 14. Valve Positions for Flushing

Heating Asphalt with Liquid Propane Gas (LPG) Burners

IMPORTANT

Circulating the asphalt in the tank while heating is recommended for faster heating and reduced carbon formation on the flues. Only when the asphalt pump is “Frozen” is it acceptable to operate the burners without circulating asphalt in the tank. However, if the asphalt pump is frozen, carefully apply heat to the pump and start circulating the material as soon as possible.

WARNING

Residual fuel in LPG burners will support a flame for several minutes after the fuel flow has been shut off. After using LPG burners, confirm that all flame has been extinguished before attempting any operation that could release flammable vapors.

Failure to ensure that the flame is completely extinguished could result in an explosion or fire that can cause injury or death.

To prevent an explosion or fire hazard: Position unit broadside to wind whenever possible to prevent volatile fumes from drifting toward burners

To prevent an explosion or fire hazard: Flues **MUST** be covered by a minimum of 6 inches of material when the burners are in operation.

To prevent an explosion or fire hazard: Do not remove material from tank in any manner when the burners are in operation.

To prevent an explosion or fire hazard: Do not drive unit when burners are operating.

To prevent an explosion or fire hazard: Do not operate burners if tank is damaged or leaking.

To prevent an explosion or fire hazard: When burners go out, allow flues to ventilate for several minutes before relighting burners.

To prevent an explosion or fire hazard: Do not heat material beyond the manufacturers recommended temperature.

To prevent foaming or violent eruption, do not heat material over 200°F if moisture is present in tank.

To prevent possible burns from material overflow, allow sufficient space in tank for expansion of material when heating.

LPG Supply Tank Requirements

Use only liquid withdrawal type supply tanks for your LPG burners.

Two types of LPG supply tanks are available: tanks for liquid type burners and tanks for vapor type burners. The LPG burners on your Etnyre distributor require a supply tank for liquid type burners. Liquid type burners will operate from a vapor withdrawal tank, however the amount of heat delivered will be dramatically reduced, and the life of the burner will be shortened.

There are three different types of LPG burners: manual control burners, burners with outfire control, and burners with automatic ignition and temperature limiting control.

Manual Control Burners

There are four valves associated with operation of the manual control burners: one at the supply tank, and three in the burner piping.

The two smaller valves (one at each burner) are bleeder type valves with a small hole drilled through the valve case. Propane liquid is supplied to the bleeder valve directly from the supply tank shutoff valve. Because of the bleeder hole in this valve, it is **NOT** possible to shut off all of the fuel to the lower burner by shutting the main valve at the burners. The main burner valve will only shut off the upper burner. The lower burner must be shut off using the supply tank valve.

WARNING

Always shut off burners using the main shutoff valve on the supply tank

The large valve located in the fuel line to the outside or upper burner is a positive cut off valve that allows all fuel to be cut off to the bleeder valve on the outside burner only.

Burner Operation

Be sure that the main supply valve and the main burner valves are fully closed and the bleeder valves are turned fully clockwise before starting.

Open the dampers in the flue exhaust stacks.

Circulate the asphalt in the tank before lighting the burners. If the asphalt is too cold to pump, start circulating the material in the tank as soon as possible after lighting the burner.

Open the valve at the supply tank and immediately light the inside burner. As soon as the burner lights, open the bleeder valve. No preheating is necessary.

! IMPORTANT

It is recommended that two persons be involved in lighting the first burner. When the main fuel valve is opened at the tank, there is an immediate trickle of gas passing through the inside burner valve. The longer the gas is allowed to collect in the flue, the more likely there will be a flashback when the burner is ignited. Having one person light the burner while the other opens the main supply valve will reduce the likelihood of a flashback.

! WARNING

To prevent possible burns, always use a torch to light the burners. Never attempt to light the burners with a match or pocket lighter.

! WARNING

A fully charged dry chemical type fire extinguisher must be within easy reach whenever the burners are operating or there is an open flame near the distributor. Minimum dry chemical capacity of the fire extinguisher should be 10 pounds.

! IMPORTANT

When the main fuel valve is opened at the bottle or tank, there is an immediate trickle of gas passing through the inside burner bleeder valve. Light the burner immediately

Check the fuel pressure at the pressure regulator. Too much pressure for a small asphalt tank will waste fuel. Too little pressure will increase heating time. Some experimentation with the pressure will allow you to determine the most efficient fuel pressure to use. The following is a good rule of thumb.

- 1000-1250 gallon tank- 15 psi
- 1500-1750 gallon tank- 20 psi
- 2000-2250 gallon tank- 25 psi
- 2250-2500 gallon tank- 30 psi
- 2750 gallon and larger- 40 psi

If necessary, adjust the flame with the bleeder valve at the burner.

When the LPG burners are operating, the outside of the fuel line up to the first coil of the burner should frost over. If no frost forms it is an indication that the burners are operating on vapor instead of liquid. This condition must be corrected immediately to prevent damage to the burners.

If after the lines frost over, the flame starts to die down and the frost melts off the fuel line, it is likely that there is moisture in the fuel supply tank. Moisture in the fuel can form ice crystals that stop the fuel flow. Your local LPG supplier can add an anti-icing agent to prevent burner icing.

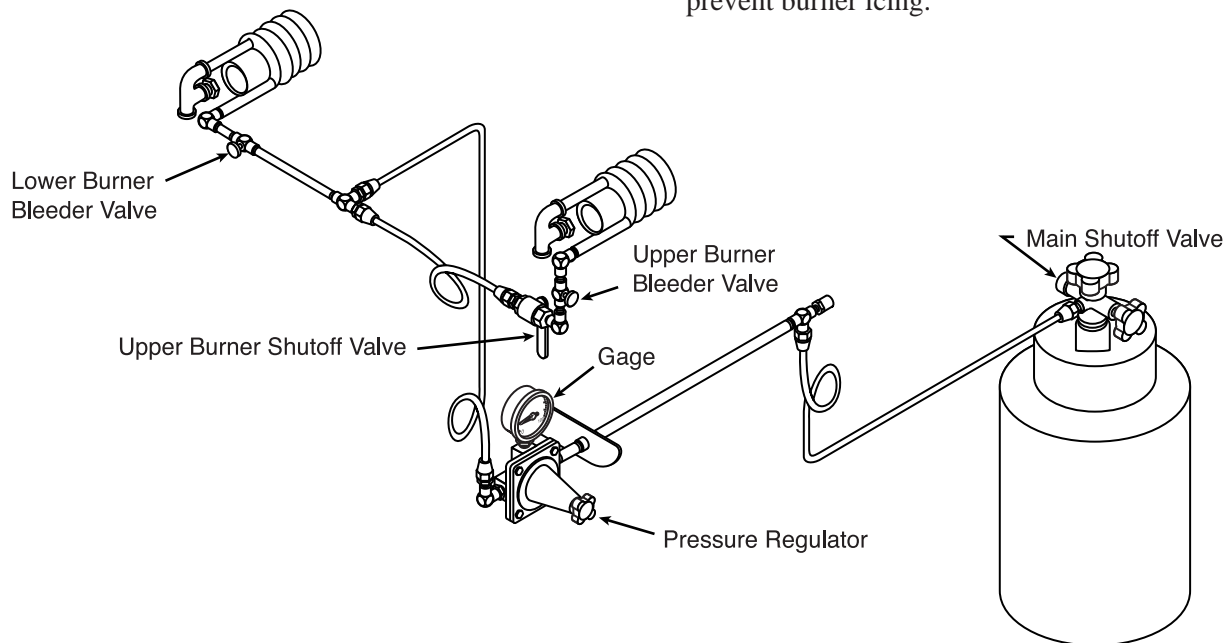

Figure 15. Manual Control Burner System

! IMPORTANT

If there is at least 6" of material covering the entire length of the upper flue, the second burner can be lit.

! WARNING

To prevent possible burns, always use a torch to light the burners. Never attempt to light the burners with a match or pocket lighter.

To ignite the second burner ensure that the bleeder valve on the burner is turned fully clockwise. Position a lit torch at the burner nozzle and open up the positive shutoff valve in the line to the burner. As soon as the low fire is established, the bleeder valve can be opened.

Never leave operating burners unattended.

! WARNING

When heating, temperatures within the tank can vary. Shut the burners off when the thermometer reaches a reading 10°F. lower than the desired temperature. Continue to circulate & monitor temperature until temperature stabilizes. Add remaining heat by operating burners for short periods, monitoring stabilized temperature after each period.

! WARNING

Calibration of thermometers should be verified to be within $\pm 2\%$ of full scale reading annually. Certification can be accomplished by a qualified laboratory or by comparing stabilized dial readings to the pencil thermometer reading. Replace any thermometer that does not meet the $\pm 2\%$ accuracy requirement.

When the desired temperature is reached, **close the main fuel supply valve, at the LPG tank, first.** Allow the burners to operate at full capacity until the fuel in the line from the tank burns out, then close both bleeder valves and the positive shutoff valve for the outside burner.

Close the exhaust stack dampers to prevent heat loss.

Burners With Outfire Controls**Equipment Design**

The burner and the burner control valves are identical to the manual operated burner system. However, burners with outfire controls are equipped with an outfire control box. The outfire controls consist of two thermocouples, a push button start switch, an electric fuel solenoid valve, a pressure regulator and a pressure gage.

The heat sensing thermocouples are positioned in each burner. If either burner loses its flame, the thermocouple senses the drop in temperature, and deactivates the fuel solenoid, and the fuel to both burners is shut off.

The only operational differences between the manual burners and burners with the optional outfire controls is the start up and shut down procedures. Unlike the manual burners, when the burners are equipped with outfire controls, no fuel flows to the burners when the main solenoid shutoff valve is closed.

Burner Operation with Outfire Controls

Turn on the Master Power switches.

Open the dampers in the exhaust stacks.

Circulate the asphalt in the tank before lighting the burners. If the asphalt is too cold to pump, start circulating the material in the tank as soon as possible after lighting the burner.

Ensure that the main burner control valve is closed and that the bleeder valves for both burners are turned fully clockwise.

! IMPORTANT

It is recommended that two persons be involved in lighting the burners. One person should hold the torch while the other person opens the valves and holds the pushbutton in.

Open the main fuel supply valve at the tank.

No fuel will be flowing at this point.

As soon as the low fire is established at the inner burner, open the positive shutoff valve to the outside burner and light the outside burner on low fire.

After 30 to 40 seconds, release the pushbutton and observe the pressure gage. If the pressure starts to drop rapidly, depress the pushbutton and hold it in for another 30 seconds. It may require a slight increase in fuel to the outside burner to adequately heat the thermocouple. Once both of the thermocouples are heated the pushbutton can be released.

! IMPORTANT

In order to activate the thermocouples, both burners must be lit on low flame even if only one burner will be used for heating. Place the ignition torch at the inside burner nozzle and depress the pushbutton in the outfire control box. Continue to hold the pushbutton in until both burners are lit.

If both burners are to be used for heating, you can now open both bleeder valves. If only the inside burner is to be used for heating, open the bleeder valve on the inside burner and allow the outside burner to remain burning on low flame so the thermocouple will be heated. Remember, if either burner flame goes out, the outfire control will shut the solenoid valve cutting the fuel off to both burners.

! WARNING

When heating, temperatures within the tank can vary. Shut the burners off when the thermometer reaches a reading 10°F lower than the desired temperature. Continue to circulate & monitor temperature until temperature stabilizes. Add remaining heat by operating burners for short periods, monitoring stabilized temperature after each period.

When the desired product temperature is reached:
Close the main fuel supply valve at the tank.

After all the fuel is burned and there is no flame at either burner, turn both bleeder valves fully clockwise and close the positive cut off valve at the burners.

Close the exhaust stack dampers to prevent heat loss.

! WARNING

A fully charged dry chemical type fire extinguisher must be within easy reach whenever the burners are operating or there is an open flame near the distributor. Minimum dry chemical capacity of the fire extinguisher should be 10 pounds.

! WARNING

Calibration of thermometers should be verified to be within $\pm 2\%$ of full scale reading annually. Certification can be accomplished by a qualified laboratory or by comparing stabilized dial readings to the pencil thermometer reading. Replace any thermometer that does not meet the $\pm 2\%$ accuracy requirement.

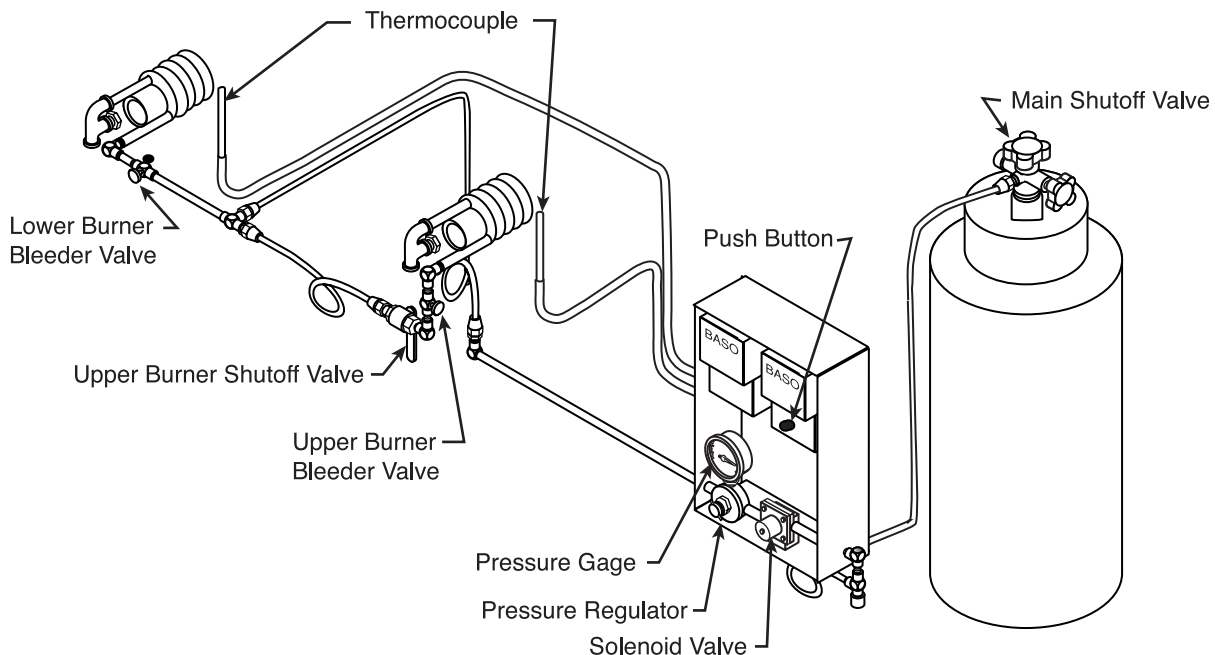

Figure 16. Outfire Controlled Burner System

Burners with Automatic Ignition and Temperature Limiting Control

Equipment Description

The temperature limiting control box contains the temperature limiting control components as well as the automatic ignition circuitry.

The automatic ignition circuit consists of two 12V coils, two spark plugs, a pair of thermocouples, (one at each burner), and a momentary pushbutton switch. The 12V coils send high voltage to the spark plugs that causes sparks to arc intermittently at each pilot burner whenever there is fuel pressure in the line from the main supply tank. The thermocouples provide a signal that indicates when there is a flame at the pilot burners. The momentary pushbutton switch on the control box is used to fire the main burners once the pilot burners have ignited and the thermocouples have been heated sufficiently.

The temperature limiting control circuit consists of a temperature probe in the distributor tank that senses the asphalt temperature, a thermostatic switch in the control box and a temperature adjustment dial on the face of the control box. When the temperature of the asphalt in the distributor is heated to the temperature selected with the temperature adjustment dial, the thermostatic switch shuts down the burners.

Burner Operation with Auto Ignition & Temp Control

Open the dampers on the exhaust stacks

Circulate the asphalt in the tank before lighting the burners. If the asphalt is too cold to pump, start circulating the material in the tank as soon as possible after lighting the burner.

Ensure that all burner valves are closed.

With this type of control, the inside or lower burner may be operated without opening the positive shut off valve to the outside burner. If both burners are to be used, the positive shutoff valve should be opened.

Open the main fuel valve at the supply tank. The spark plugs will begin to arc and will ignite the pilot burners.

Set the thermostat to the desired temperature.

Allow the pilot burners to heat the thermocouple probes for at least 2 minutes. When the pilot burners have heated the thermocouples sufficiently the sparker will stop. Press the cycle button to fire the main burners. The bleeder valves may then be opened.

On new or rebuilt units, monitor the product thermometer to make certain that the burners shut down when the desired temperature is reached. (as set on the temperature adjustment dial. If the burners do not shut

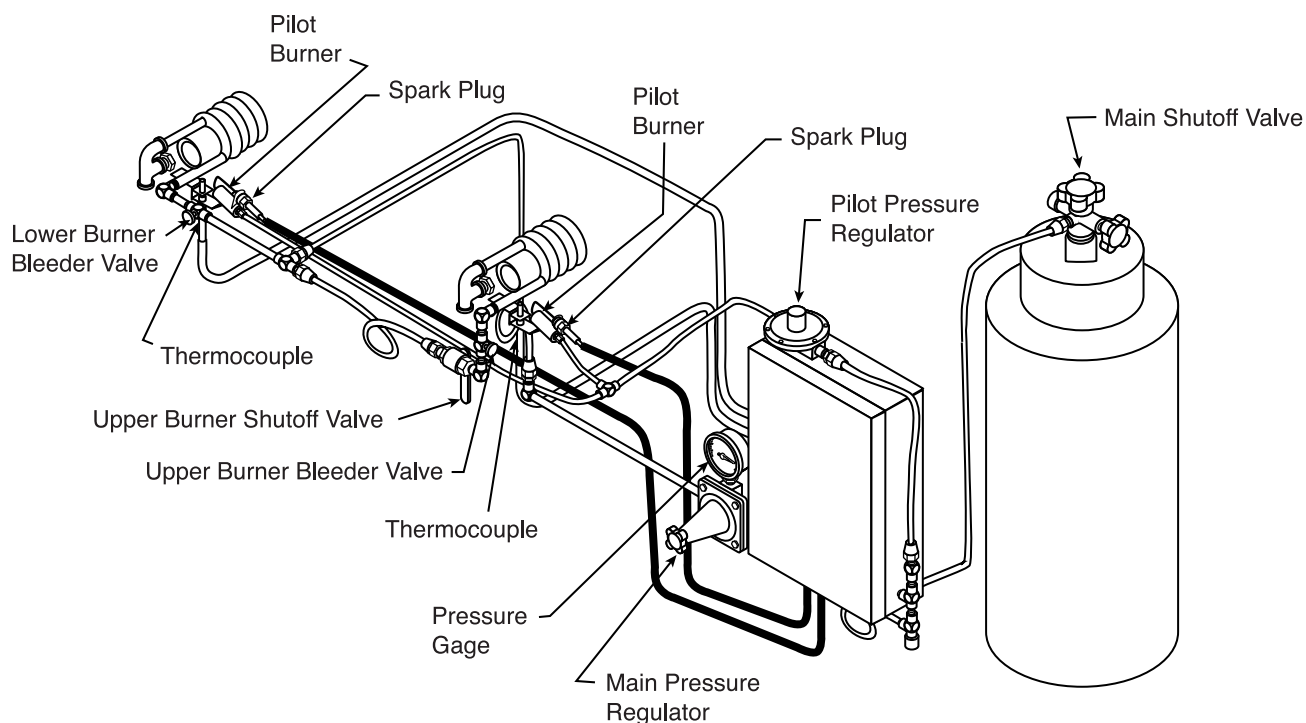

Figure 17. Burner System with Auto Ignition & Temperature Control

down at the correct temperature, refer to “Calibrating the Thermostat”.

Once the burner shuts off automatically, it will not restart until the cycle button is again depressed.

To shut the system down: Close the main fuel supply valve at the tank.

Increase the thermostat setting 50 to 75°F higher and push the start button. This will bring on the main burners and quickly burn off all of the fuel in the line between the tank and the control box. The pilot burners may continue to burn for a short time after the main burners cut off. Do not draw material from the tank as long as there is a flame present.

Close the exhaust stack dampers.

Electric Driven Burner Operation

Open the dampers in the exhaust stacks.

To light the burner, turn on the “Lower Burner Power” switch.

If upper burner operation is desired, turn on the “Upper Burner Power” switch.

Do not heat the material higher than the spraying temperature recommended by the asphalt supplier.

To shut down the burners, turn off the burner power switches.

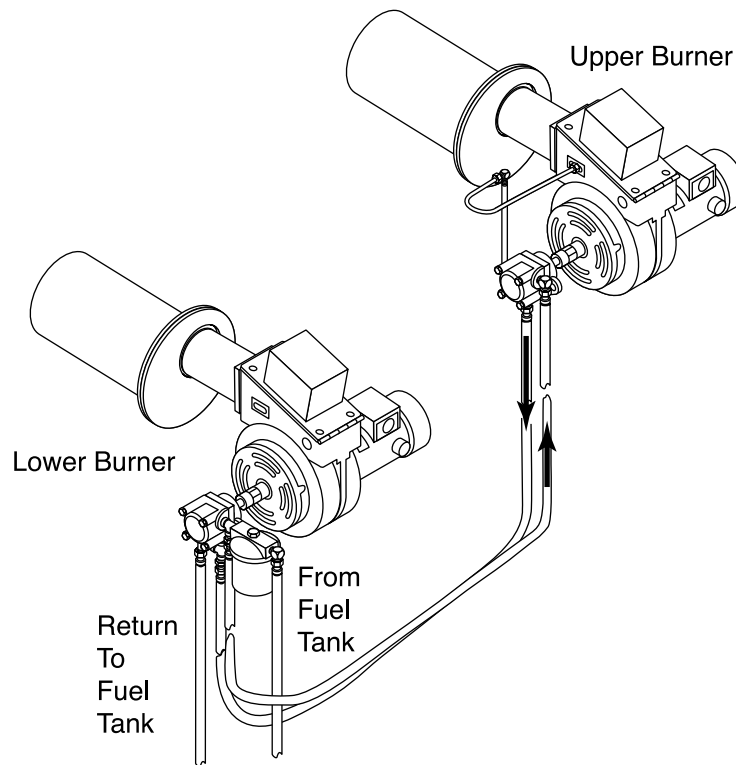

Figure 18. Electric Burner System

Troubleshooting

MAINTENANCE

| Trouble | Cause | Remedy |
|---|---|---|
| Spray Fogs | Pump speed too fast for size of nozzle | Lower pump speed or change nozzles. See "Establishing Flow Rate/Ground Speed Ratio." |
| Spray Streaks Flow | Pump speed too slow. Nozzles not at proper angle. Spray bar at improper height above ground. Material temperature too low. | Increase pump speed. See "Establishing Rate/Ground Speed Ratio." Adjust angle of nozzles. Adjust spray bar height. Heat material to correct temperature. |
| Spray Lacks Pressure | Pump speed too slow. One or more control valves in incorrect position, not fully opened or closed, or leaking. Suction strainer plugged. | Adjust pump speed. Check position of all control valves. Be sure all valves are fully opened or closed. Repair leaking valves as necessary. Clean suction strainer. |
| All Nozzles Do Not Cut Off Spray | Spray bar linkages not adjusted correctly. | Adjust linkage. |
| Pump Will Not Turn, Or Turns Slowly. | Material in tank or pump below pumping temperature. Air leak in suction line from reservoir to filter to inlet of charge pump. Hydraulic system pressure low. Low oil in hydraulic reservoir. Spray bar valves set improperly. Defective Hyd. motor. | Heat material to proper pump temperature. Locate and repair leak. Raise pressure. Add hydraulic oil to correct level. Correct spray bar valve settings. Check for excessive case drain in motor. Repair or replace defective components. |
| Hydraulic Oil Overheats. | Material in tank or pump below pumping temperature. Air leak in suction line from reservoir to filter to inlet of charge pump. Low oil in hydraulic reservoir. Spray bar valves set improperly. | Heat material to proper pump temperature. Locate and repair leak. Add hydraulic oil to correct level. Correct spray bar valve settings. |

| Trouble | Cause | Remedy |
|--|---|---|
| <p>Spray Bar Supply Tube Ball Joints Leak</p> <p>Application Rate Varies</p> | <p>Ball joint O-ring is loose.</p> <p>Quantity of material in tank not being measured accurately.</p> <p>Suction strainer plugged.</p> <p>Hydrostatic controls not firmly positioned.</p> <p>Suck back valves not fully closed.</p> | <p>Replace ball joint O-ring.</p> <p>Use Etnyre measuring stick for accurate readings. Be sure tank is level when measuring.</p> <p>Clean suction strainer regularly.</p> <p>Ensure that all controls are firmly locked in place.</p> |

Maintenance

Electrode Assembly Adjustments

1. Adjust electrode assembly per Figure 20.

NOTE: Before installing electrode assembly, check that blower wheel turns freely and that all set screws are tightened securely.

2. Install electrode assembly into air tube unit. Use escutcheon plate for mounting (see Figure 21).

MAINTENANCE

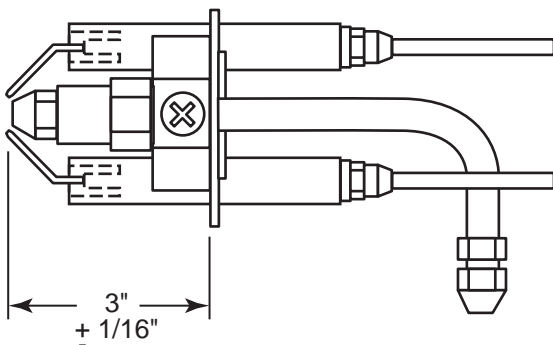

Figure 19. Burner Electrode Adjustments

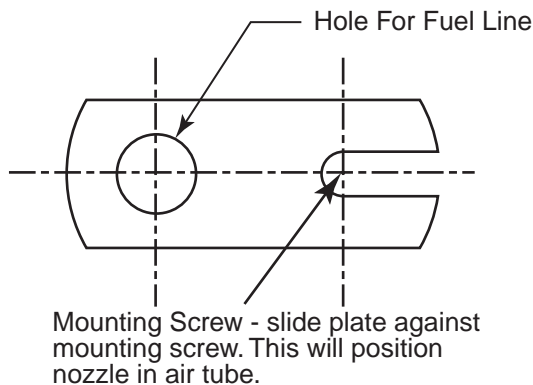

Figure 20. Electrode Assembly Installation

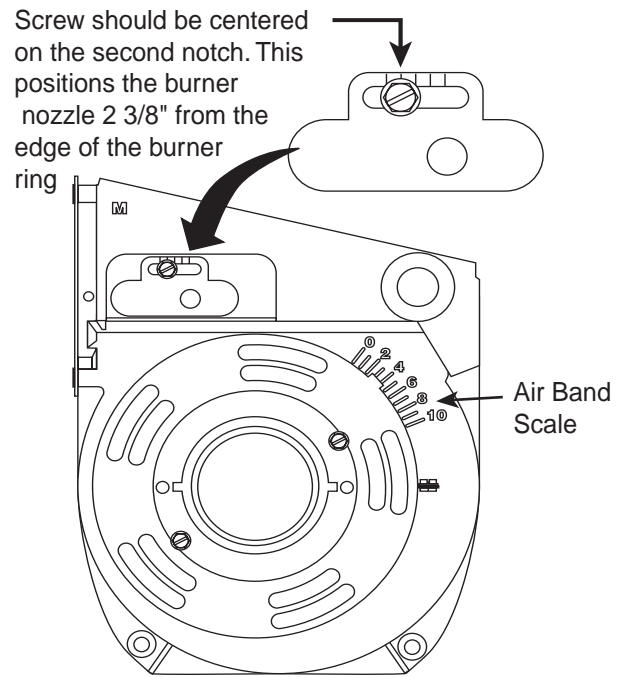

Figure 21. Nozzle Adjustment

Burner Air Band Settings

1. Close bulk air bank (outside diameter band).
2. Set end air band between 3.5 - 4.0 on scale (see figure 21a).
3. Open covers or dampers on exhaust stacks.

WARNING

To prevent an explosion or fire hazard: Keep area free of sparks or open flames when testing burners.

Check Ignition Transformer Spark

1. Turn on master power switch in rear control box.
2. Turn on Burner Power switch.
3. Hold an insulated screwdriver approximately 1 to 1-1/2 inches above the two wire springs on the transformer and hold the ignition switch down. It should be possible to jump a spark across the 1 to 1-1/2 inch gap

between the springs and the screwdriver. If unable to generate a spark, check the voltage at terminal spades of the 12 volt ignition control box. Voltage must be 12 volts DC minimum. If voltage is incorrect or not present, check ground wiring.

4. Reposition ignition transformer and secure to burner housing.

Fire Burners

1. Ensure that fuel oil pressure is 125 PSIG.



WARNING

To prevent an explosion or fire hazard: Flues must be covered by minimum 6 inches of material when burners are in operation. When testing burners, do not run burners for more than 15 seconds if tank is empty.

2. Hold ignition switch down until ignition occurs, and keep switch down for an additional 2 to 4 seconds before releasing.

3. Run burner for 15 seconds maximum, then shut down.

Replacing Speed Pickup

1. Loosen locknut and remove old speed pickup.
2. Turn in the new speed pickup clockwise by hand until the bottom end gently touches the internal speed ring.
3. Back it out counter clockwise 1/2 to 3/4 turn.
4. Using a 1/2 inch wrench to hold the speed pickup, torque the locknut to 10 lb-ft (13Nm) with an 11/16 inch wrench.

Adjusting Spray Bar Nozzle Angle

Adjust nozzles to obtain an angle of approximately 30° with bar centerline (see Figure 22). Every nozzle should be at the same angle.

NOTE: A nozzle adjustment wrench is supplied in the tool box of each new unit.

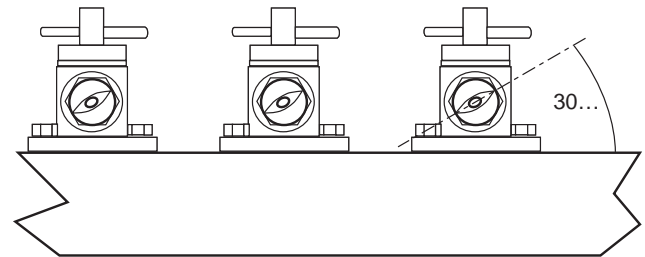

Figure 22. Nozzle Angle Adjustment

Adjusting Spray Bar Height

Lower spray bar and adjust so that nozzles are approximately 12 inches above road when tank is empty. At this height spray fans will overlap to provide triple lap coverage. See Figure 23

NOTE: Under heavy wind conditions it may be necessary to lower spray bar further.

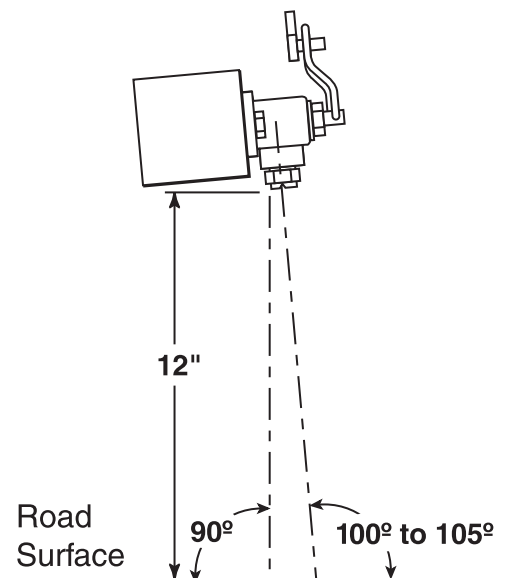

Figure 23. Nozzle Height Adjustment

Servicing The Etnyre P-15 Pump

Vacuum Check

1. Flush pump with 3 quarts of diesel fuel through fill line.
2. Set controls for filling operation.
3. Install vacuum gauge in fill line cap.
4. Operate pump at 140 GPM on pump tachometer. A vacuum reading of less than 5Hg. (inches of mercury) after 2 minutes of operation indicates a vacuum leak or a worn pump.

Pump Disassembly And Inspection

1. Remove 20 capscrews from perimeter of pump end plate (see Figure 24).
2. Install two capscrews in the threaded holes near the outer edge of the end plate at approximately the 5 o'clock and 11 o'clock positions. Tighten the capscrews evenly to force the endplate away from the pump body.
3. Remove the endplate, impeller shafts and impellers (gears) as an assembly.
4. Clean the interior of the pump case. Slide your fingers across the interior surfaces of the case. If a narrow raised area can be felt midway between the front and the rear of the case, the entire pump should be replaced.
5. If there is no raised area, measure the bore of the case at its widest point horizontally (side-to-side). This measurement must not exceed 9.910 inches.

6. Next, measure the case bore vertically at a point 2.8 inches from each side. The vertical measurement must not exceed 5.660 inches. If any bore measurements exceed these limits, the entire pump must be replaced.

7. If inspection indicates the pump case is acceptable, measure the outside diameter of the impeller gears. Measure the impeller gears from tooth point to tooth point on teeth directly opposite each other. The minimum outside diameter of the gears should be 5.635 inches. The minimum length of the gears should be 3.628 inches.

8. If any impeller gear is undersize, the entire four-gear set must be replaced.

9. End plate gasket thickness should be 0.014 - 0.016 inches.

10. Divider plate thickness should be 0.127 - 0.128 inches.

Impeller Installation And Pump Assembly

Each impeller gear set uses a series of dots on the gear faces to indicate position of the gears within the pump. Refer to Figure 24 for proper positioning of the gears. The dots must face away from the divider plate (towards the ends of the pump). Install the impellers in numerical order.

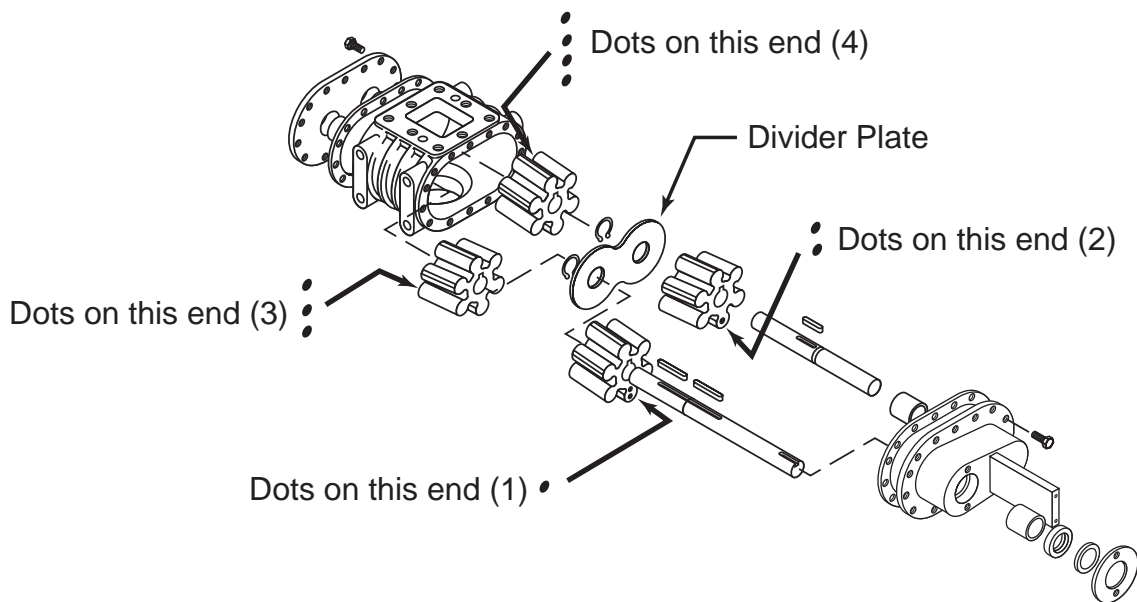

Figure 24. Etnyre Asphalt Pump

General Fuel Data And Heating Terminology

Fuel Data

| Fuel | Weight Per Gallon | BTU Content |
|-------------|-------------------|--------------------|
| #2 Fuel Oil | 7.49 lbs | 144,300 per gallon |
| Kerosene | 6.97 lbs. | 134,500 per gallon |
| Propane | 4.20 lbs. | 91,500 per gallon |

Approximate Burner Fuel Consumption

Low Pressure Fuel Oil

935,000 BTU @ PSI
6.5 GPH per burner
(144,000 BTU per gallon)

Kerosene Generating

575,000 BTU @ 40 PSI
4.25 GPH per burner
(135,000 BTU per gallon)

Heating Terminology

Flash Point (Open Cup)

The temperature at which a flammable liquid in an open container emits vapor that will flash when exposed to a direct flame. This temperature is lower than required for the liquid mass to ignite.

Closed Flash Point

The temperature at which a flammable liquid in a closed container emits a vapor that will flash when exposed to a direct flame. This temperature is lower than required for the liquid mass to ignite. The closed flash point is generally 30° (F) lower than the open cup flash point.

Fire Point

The temperature at which a flammable liquid emits a vapor at a rate that will continue to burn after it has flashed.

Ignition Temperature (Kindling Temperature)

The lowest temperature at which a combustible material will continue to burn once ignited.

Convection

Heat transfer by a flow of a liquid or gas over a solid material. Example: Flues in asphalt tank are heated from hot gases passing through them, or, heat transfer coils in tank are heated from steam or hot oil passing through them.

Conduction

Heat transfer through a solid mass by direct molecular contact. Example: Heat applied only to one end of a metal rod will be transferred throughout the entire body by molecular transfer.

Hydraulic Fluid Requirements

General Information

The ability of a hydrostatic transmission to maintain desired performance for the expected life depends on the quality of fluid being circulated in the units. Fluid quality can be measured in three general categories: lubricity, contaminants, and temperature. Obtaining satisfactory values in these three areas depends on the fluid and the circuit in which it is used.

Etnyre field service experience indicates that most transmission failures result from a breakdown of fluid quality. Primary causes are solid particle contamination and overheating. Water or oil in the fluids are also significant contributors. These problems are usually the result of poor maintenance. Sometimes fluid selection can lessen the impact of unusual environmental factors.

Hydraulic fluid requirements

The catalog ratings and performance data are based on operating with good quality petroleum based fluids. Premium hydraulic fluids containing high quality rust, oxidation and foam inhibitors are required. These include premium turbine oils, API CD engine oils per SAE J183, M2C33F or G automatic transmission fluid (Type F), power shift transmission fluids meeting Allison C-3 or Caterpillar TO-2, and certain specialty agricultural tractor fluids.

Although fluids containing anti-wear additives are not necessary for satisfactory performance, when used, the fluids must possess good thermal and hydrolytic stability to prevent wear, erosion and corrosion of the internal components.

Where water contamination is likely due to condensation, operation in a damp environment or frequent splashing, a fluid with outstanding hydrolytic stability is recommended. Consult the Etnyre Service Department for recommendations for these fluids. Avoiding the use of Dexron II transmission fluids which *do not* meet Allison C-3 specification is recommended.

Viscosity & Temperature Requirements

The fluid must have sufficient viscosity to maintain an oil film at the bearing surfaces. This depends on fluid selection and on operating temperature. Recommended viscosity for best life and efficiency, and minimum for intermittent and continuous operation is listed below.

Fluid Viscosity Limits For Petroleum Based Fluids

| | |
|--------------------------------|-----------|
| Maximum Continuous SUS (cSt) | 500 (110) |
| Optimum Viscosity SUS (cSt) | 70 (13) |
| Minimum Continuous SUS (cSt) | 55 (9.0) |
| Minimum Intermittent SUS (cSt) | 47 (6.4) |

Viscosity index improved (multi-viscosity) fluids may noticeably shear down in service when used in hydrostatic transmissions. This will lower the operating viscosity below the originally specified value. The lowest expected viscosity must be used when selecting fluids. Consult your fluid supplier for details on viscosity sheardown.

Fluid temperature affects the viscosity of the fluid and resulting lubricity and film thickness. High temperatures can also limit seal life, as most nonmetallic seals are adversely affected by use at elevated temperatures. Also, fluids may break down or oxidize at high temperatures, reducing their lubricity and the resulting life of the unit. Cavitation is more likely at high temperature. Recommended limits for operating temperatures are tabulated below.

Fluid Temperature Limits For Petroleum Based Fluids

| | |
|--------------------|--------|
| Continuous Limit | 180°F. |
| Intermittent Limit | 220°F. |

These temperature limits apply at the hottest point in the transmission, which is normally the motor case drain.

Heat problems sometimes occur because of problems with one of the circuit components. A partially stuck relief valve will heat up the oil rapidly. Circuit components that have developed high internal leakage rates will contribute to heat generation.

Contamination Levels

Clean fluid implies the absence of impurities such as solid particles, water and air. Contamination control includes proper design, installation, and maintenance of hydraulic components.

The reservoir is designed to limit entry of contamination during servicing and operation. A sealed reservoir with a low pressure relief valve reduces the intro-

duction of contaminants while maintaining inlet and case drain pressures below the maximum recommended.

The purpose of the filter in a system is to clean the oil at initial start up and to maintain acceptable levels of particle contaminants as they are ingested or generated during operation of the system. Filtration is a matter of controlling the particle sizes and their respective quantities to appropriate levels so as to avoid degradation of the system components and thereby assure the desired life.

Fluid contaminant profile requirements for Etnyre hydraulic units have been determined empirically based on measuring fluid quality in successful application, and in laboratory tests designed to evaluate hydraulic unit contaminant sensitivity. General contaminant levels have been developed based on this experience and are shown in Figure 25.

Acceptable contamination levels at machine start up for the system loop should be equal to or better than Curve D. The machine may be exercised to 500 psi but should not be worked (pressure over 500 psi) until the oil cleanliness meets or exceeds Curve C.

The machine should clean up during a relatively short period of normal operation to meet the oil cleanliness level of Curve A or Curve B. A system that meets Curve A will provide the user with a longer trouble-free operating life than one that meets Curve B. The Curve A cleanliness level should be met in systems exceeding the continuous pressure limit for 1000 hours/years machine use.

Some control valves may require better contamination limits than specified in Figure 25. Controls with small area screens or low force level values may be susceptible to malfunction from contamination.

The contamination sensitivity of components generally increases with higher pressure, temperature or speed. A better fluid contaminant profile may be required for systems which operate near the extremes of their ratings. Short life or infrequent operation requirements may increase allowable contaminants.

The selection of a filter depends on a number of factors including the contaminant ingress rate, the generation of contaminants in the system, the required fluid cleanliness, and the desired maintenance interval. Filters are selected to meet the above requirements using rating parameters of efficiency and capacity.

Filter efficiency may be measured with a Beta ratio. For simple closed circuit transmissions with controlled reservoir ingress, a filter with a Beta ratio of 1.5 to 2 has been found to be satisfactory. For some open cir-

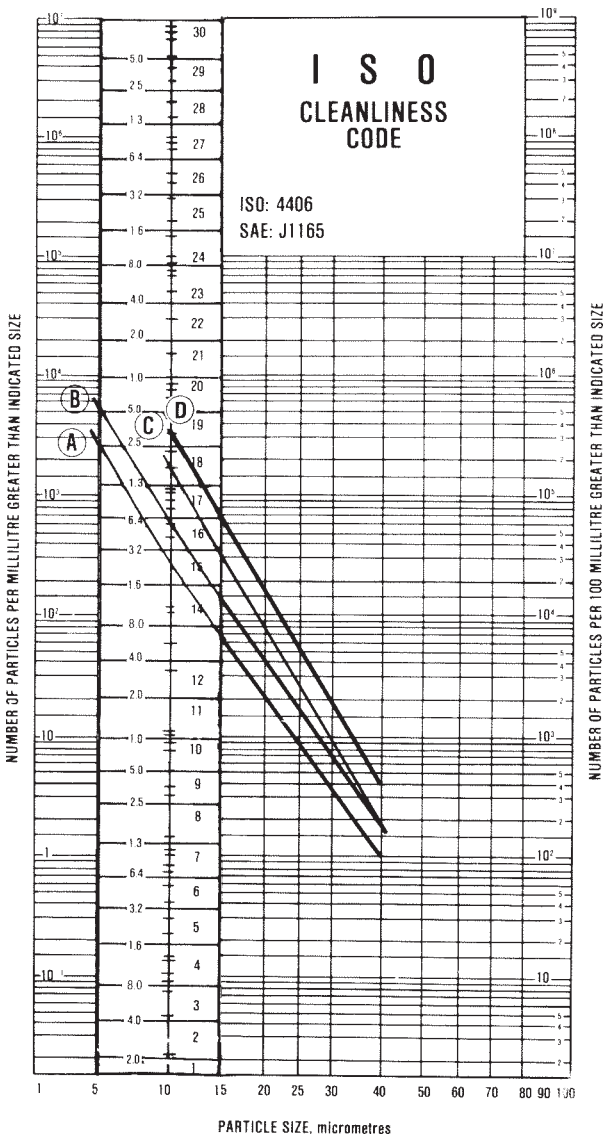

Curve A

Desired limit for longer life (3500 PSI continuous system pressure)

Curve B

Continuous operating limit (2000 PSI continuous pressure) system

Curve C

Limit at machine ship and new fluid added to transmission

Curve D

Limit at machine start up

Figure 25. Fluid Cleanliness Chart

cuit systems, and closed systems with cylinders being supplied from the same reservoir, a considerably higher filter efficiency is recommended. This applies to systems with gears or clutches using a common reservoir. For these systems, Beta ratios of 10 or 20 are typically required.

The filter capacity required depends on the amount of contaminants ingressed and retained in the filter and

the desired maintenance interval. As a rough guide, a capacity in grams equal to twice the charge flow in GPM has been found to be satisfactory for our systems.

Since each system is unique, the filtration requirements for that system will be unique and must be determined by test in each case. It is essential that monitoring be the final criteria for judging the adequacy of the filtration system.

MAINTENANCE

| Lubrication Chart | | | | |
|-------------------|-------|--------------------------|-----------|---|
| INTERVAL | POINT | IDENTIFICATION | LUBRICANT | QUANTITY |
| DAILY | 1 | Pump Discharge Strainer | Clean | |
| WEEKLY | 2 | Air Oiler | EO | Fill |
| | 3 | Manhole Cover | EO | Sparingly |
| | 4 | Spray Bar Controls | AS | Sparingly |
| 30 DAYS | 5 | 4-way Valve Handle | MPG | Sparingly |
| | 6 | Bar Swivels | MPG | Sparingly |
| | 7 | Bar Carry Mechanism | EO | Sparingly |
| | 8 | Mechanism Swivels | MPG | Sparingly |
| | 9 | Mechanism Pivot Bar Ends | MPG | Sparingly |
| | 10 | Mechanism Cylinders | MPG | Sparingly |
| SERVICE | 11 | Bell Crank | AS | Sparingly |
| | 12 | PUMP SHAFT | AS | Sparingly |
| | 13 | Bar Balls | MPG | Sparingly |
| | 14 | Hydraulic Reservoir | HTF | 3/4 Full |
| | 15 | Hydraulic Oil Filter | | Replace if Vacuum shows in the red area |

MPG: Multi Purpose Grease MIL-G-18458B-SH

EO: (Engine Oil) 10W MIL-L-2104-F

AS: Anti-Seize MIL-T-5544

HTF: Hydraulic Transmission Fluid - Type F

NOTE: Fill line oiler, located on outlet side of air reservoir, with light oil as needed. Also wipe cylinder rods clean and lightly oil. Drain water from air reservoir daily.

NOTE: Fill Hydraulic Tank completely for winter storage. This will prevent condensation in the reservoir. Drain down to thermometer hole prior to use.

Tach Calibration



Instructions for calibrating pump speed for units with 309 pulses per gallon only (hydraulic motor #6603157 with 4.39 to 1 ratio gearbox).

For coarse calibration:

Setting
"8"

1

Select setting 8 on back of pump tach.



Hex Wrench

2

Using 5/64 inch or 2 mm hex wrench turn calibration fully clockwise.



Hex Wrench

3

Remove wrench and reinsert with wrench leg directly on top of mounting thread.



Hex Wrench

4

Turn calibration counterclockwise until parallel with both mounting threads.

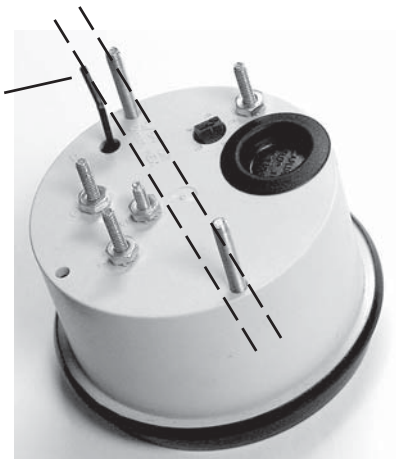

MAINTENANCE

For fine calibration:

1. Complete coarse calibration.
2. Using strobe tach measure asphalt pump shaft speed in RPM.
3. Multiply RPM by 0.61 to get calculated GPM.
4. Turn calibration until calculated GPM matches pump tach.

Etnyre Spraybar Nozzles

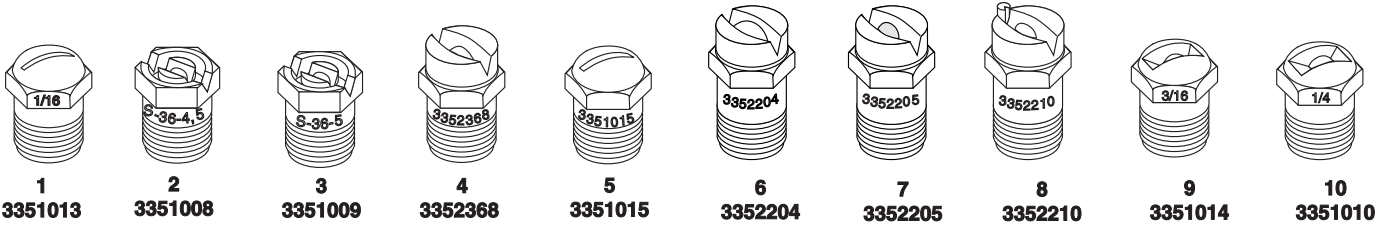

| Ref. | Part No. | Description | Application Per Square Yard | Application (Metric) Liters Per Square Meter | Flow Gallons Per Minute Per Foot |
|------|----------|-----------------------|-----------------------------|--|----------------------------------|
| 1 | 3351013 | 1/16" Coin Slot | .05 – .20 | .23 – .90 | 3.0 to 4.5 |
| 2 | 3351008 | S36-4 V Slot | .10 – .35 | .45 – 1.60 | 4.0 to 7.5 |
| 3 | 3351009 | S36-5 V Slot | .18 – .45 | .82 – 2.00 | 7.0 to 10.0 |
| 4 | 3352368 | Multi-Material V Slot | .15 – .40 | .68 – 1.80 | 6.0 to 9.0 |
| 5 | 3351015 | 3/32" Coin Slot | .15 – .40 | .68 – 1.80 | 6.0 to 9.0 |
| 6 | 3352204* | Multi-Material V Slot | .35 – .95 | 1.60 – 4.30 | 12.0 to 21.0 |
| 7 | 3352205* | Multi-Material V Slot | .20 – .55 | .90 – 2.50 | 7.5 to 12.0 |
| 8 | 3352210 | End Nozzle (3352205) | .20 – .55 | .90 – 2.50 | 7.5 to 12.0 |
| 9 | 3351014 | 3/16" Coin Slot | .35 – .95 | 1.60 – 4.30 | 12.0 to 21.0 |
| 10 | 3351010 | 1/4" Coin Slot | .40 – 1.10 | 1.80 – 5.00 | 15.0 to 24.0 |

* Recommended nozzles for seal and chip with emulsified asphalts.

Serial Number Plate Location

The Serial Number Plate is a brass plate located on the left side of the vehicle toolbox. Generally, the serial number has a letter prefix followed by four numbers.

The unit serial number is also stamped on the left front tank mounting leg.

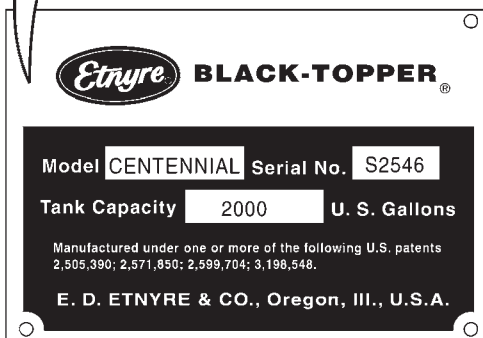
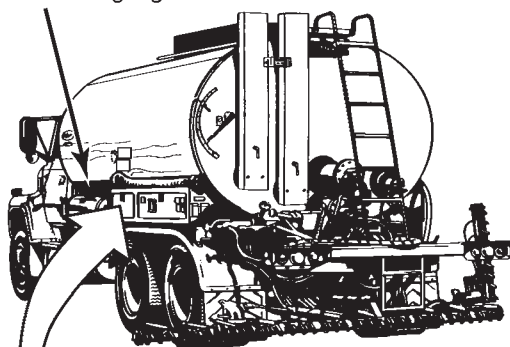

Figure 25. Serial Number Plate Location

| Decimal Equivalent Chart | | | |
|--------------------------|---------|----------|---------|
| Fraction | Decimal | Fraction | Decimal |
| 1/16 | .06 | 9/16 | .56 |
| 1/8 | .12 | 5/8 | .62 |
| 3/16 | .19 | 11/16 | .69 |
| 1/4 | .25 | 3/4 | .75 |
| 5/16 | .31 | 13/16 | .81 |
| 3/8 | .38 | 7/8 | .88 |
| 7/16 | .44 | 15/16 | .94 |
| 1/2 | .50 | 1 | 1.00 |



Something Wrong with this manual?

If you find inaccurate or confusing information in this manual, or just have a suggestion for improvement, please let us know.

Mail or FAX this form to us at: E. D. ETNYRE & CO. 1333 S. Daysville Rd.
 Oregon, Illinois 61061 • Fax: 800-521-1107 • www.etnyre.com
 Attn: Service Manager

Recommended changes from: _____

Address _____

City, State, Zip _____

Phone _____

Date Sent _____

Manual Number (upper right corner of front cover) _____

Manual Title _____

Explain the problem in the space below.

| Page Number | Reference Number | Paragraph Number | Figure Number | Problem (please be specific) |
|-------------|------------------|------------------|---------------|------------------------------|
| | | | | |